

GULLBERG *GJ* JANSSON

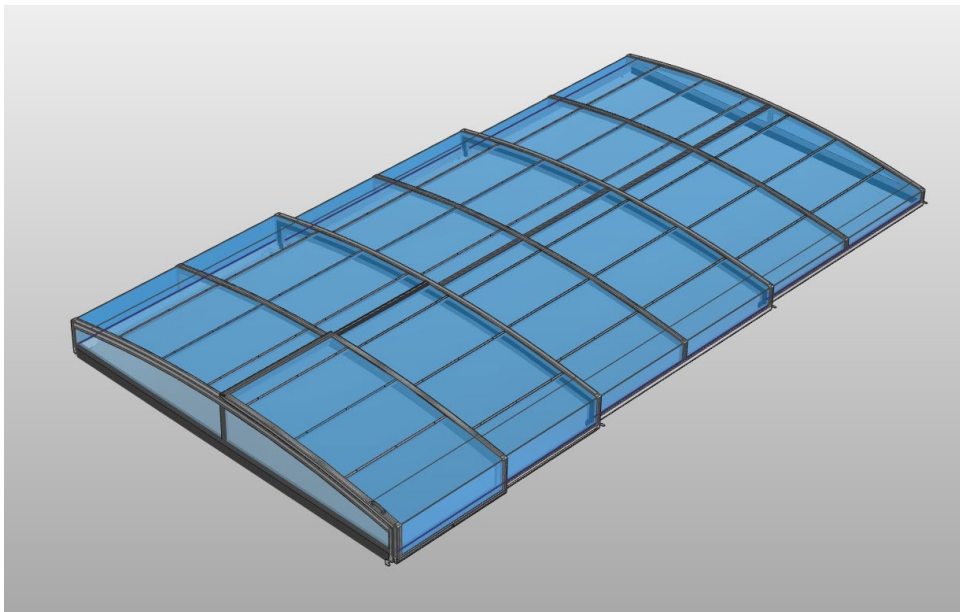

P O O L T A K

LEIA

I. Allmän Monteringsmanual

OBS!!

Scanna nedan QR kod för länk till senast uppdaterad manual , monteringsvideo och garantivillkor.



Viktigt!

Läs detta innan du monterar ditt Leia boxtak !

Underlag / Installation på trädäck

Det är av yttersta vikt att underlaget är stabilt och jämnt för att taket skall fungera felfritt. Vi rekommenderar att lägga extra regler (kottlingar) där skenan ska vara. Detta för att säkerställa extra stabilitet under skenan.

Öppna pallen

Var uppmärksam så att den öppnas från rätt håll för att undvika onödiga skador. Långsidan som är skruvad skall öppnas enligt markeringar på pallen.

Skruvarna

Dessa ska fettas in före montering för att undvika skador på gänga eller brott på skruv.

Skyddsplast på panelerna

Skyddsplasten skall avlägsnas innan montage. Tänk på att inte utsätta panelerna för solljus när skyddsplasten sitter kvar då detta kan orsaka att skyddsplasten "bränner fast" i panelen.

Gummilister

Tänk på att dessa krymper lite över tid, dra aldrig i dem vid montering utan "mata/tryck" snarare på lite extra. Panelens gummilist kan eventuellt glida ur aluminiumprofilen pga. termisk expansion. Om detta händer så spraya med fönsterputs och tryck tillbaka gummilisten.

Användarmanual och underhåll

Snöbärighet

Vid kraftigt snöfall måste snön tas bort från pooltaken, tänk på att blötsnö väger mycket och kan deformera pooltakets aluminiumkonstruktion. Gullberg och Janssons pooltak är godkända enligt standarden (NF P90-309) och är testade för 45kg/m² vikt.

Vind och barnsäkerhet

Sektionerna måste vara fixerade/låsta med bifogade stormförankringar för att AFNOR NF P 90309 standarden gällande vind och barnsäkerhet skall uppfyllas. Dörren skall vara låst.

Yttröst

Detta omfattas inte av garantin då det inte påverkar takets konstruktion eller funktion. Yttröst på fästelement av rostfritt stål (A2, 1.4301) kan uppkomma av felaktiga vattenvärden i poolen eller t ex aggressiva rengöringsmedel.

Tips! Prova att avlägsna med en mjuk trasa och flytande rengöringsmedel (utan slipmedel).

Skenorna

Måste hållas rena från skräp (sand, grus, löv och grenar).

Panelerna

Ska endast rengöras med rent vatten. Använd ej högtryckstvätt, borstar, svampar eller rengöringsmedel med slipmedel.

Rörliga delar

Såsom lås, fjäder etc. kan med fördel behandlas med t ex WD40 före och efter säsongen.

Pooltaket

Ska öppnas och stängas med försiktighet, bromsa in vid varje automatisk låsning eftersom delarna är gjorda för att positionera och fixera sektionerna inte bromsa och stoppa sektionerna. Skenlåsen är slitagedelar och kan behövas bytas efter några år.

OBS! Kontakta alltid ditt försäkringsbolag för att säkerställa vad som gäller om det skulle ske en yttre påverkan på just ditt pooltak.

Skador som uppkommer pga. att ovanstående instruktioner inte följs omfattas inte av garantin.

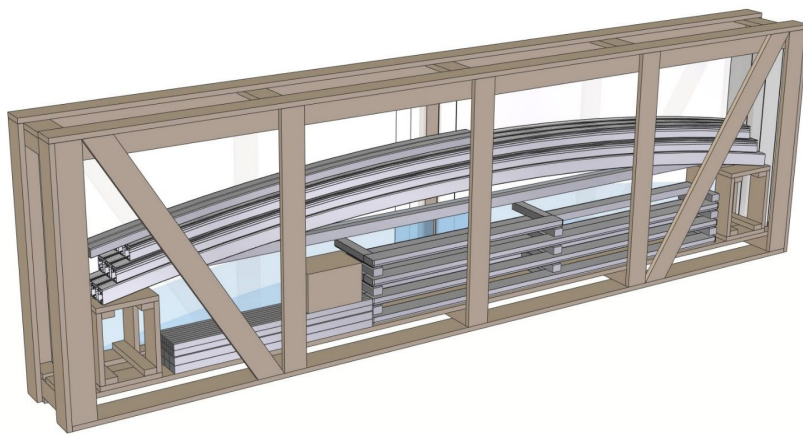

Skjuddörr på högersidan

Sett framifrån största sektionen:

2. Skeninstallation 3-4
3. Största sektionen 4-11
4. Övriga sektionerna 12-18
5. Lister och övriga detaljer 19-21
6. Skjuddörr 22-27
7. Front och bak gavel 28-29
8. Slutmontering 30-34

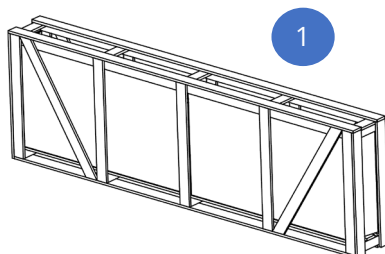

1

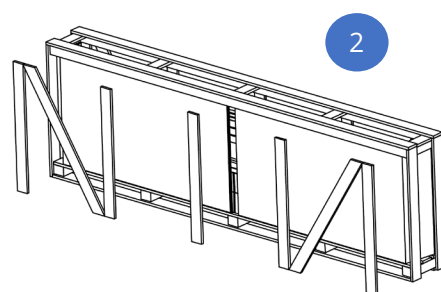

2

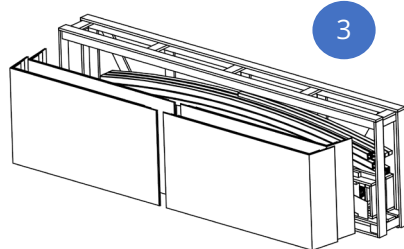

3

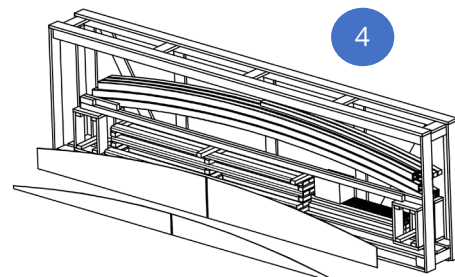

4

Skjuddörr på vänstersidan

Sett framifrån största sektionen:

2. Skeninstallation 35-36
3. Största sektionen 36-43
4. Övriga sektionerna 44-50
5. Lister och övriga detaljer 51-53
6. Skjuddörr 54-59
7. Front och bak gavel 59-61
8. Slutmontering 62-66

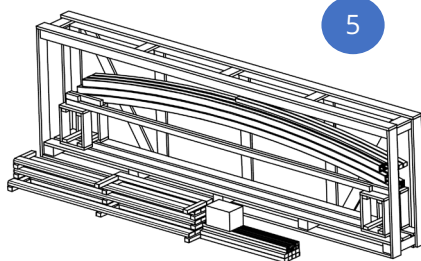

5

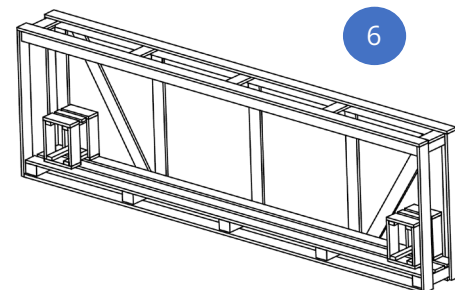

6

OBS!

1. Ta av skyddsplasten på panelerna innan de monteras.
2. Fetta alltid in skruvarna innan de skruvas i.



2.01

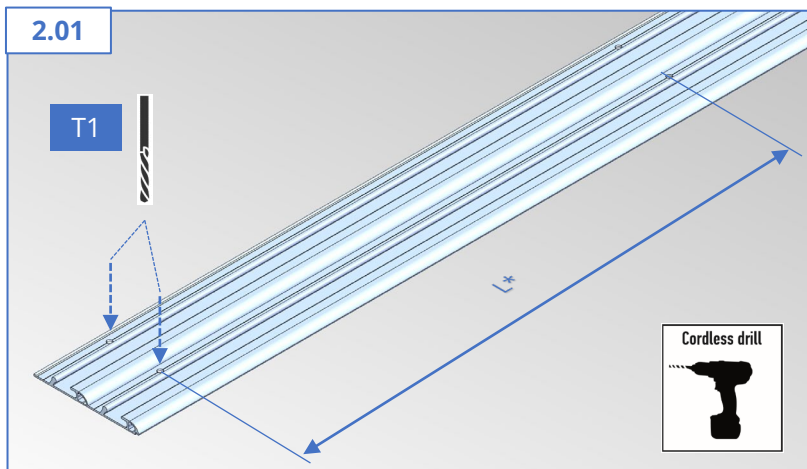

L* - Borrhålets position olika beroende på modell!
(Se sidan 3 i modellspecifik monteringsmanual)

OBS! Skruvarna ska försänkas

2.02

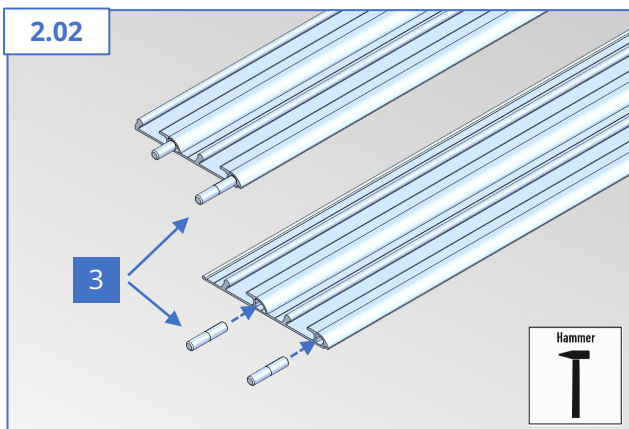

2.03

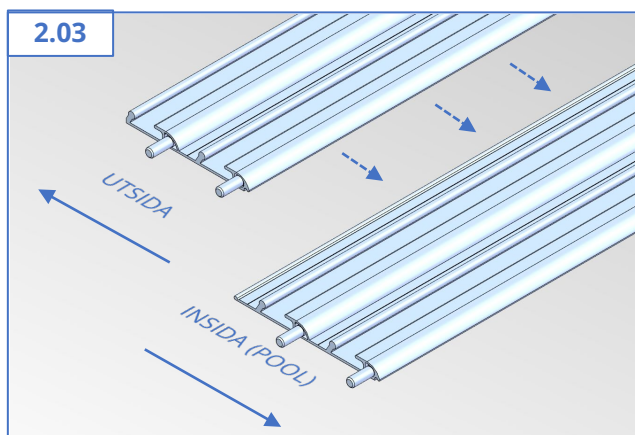

2.04

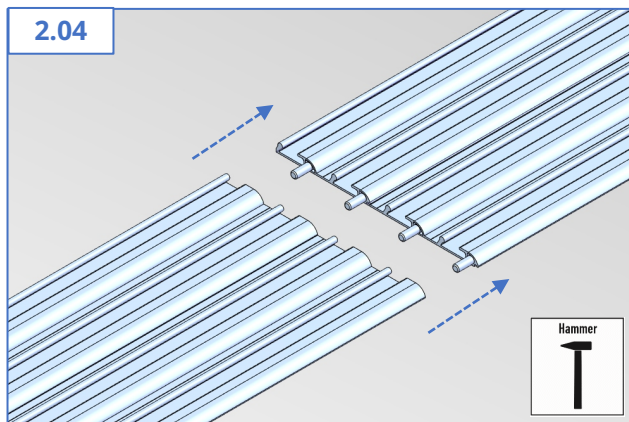

2.05

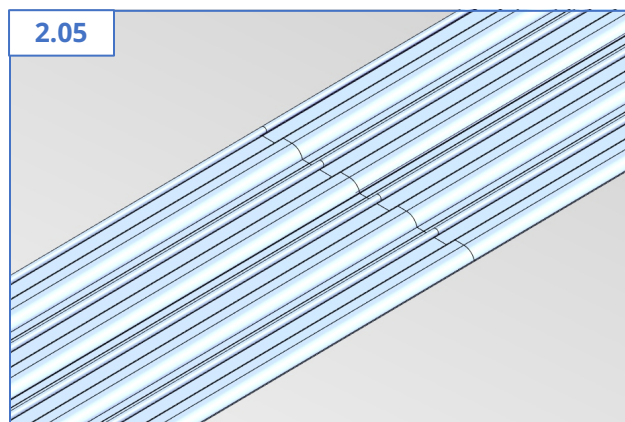

2.06

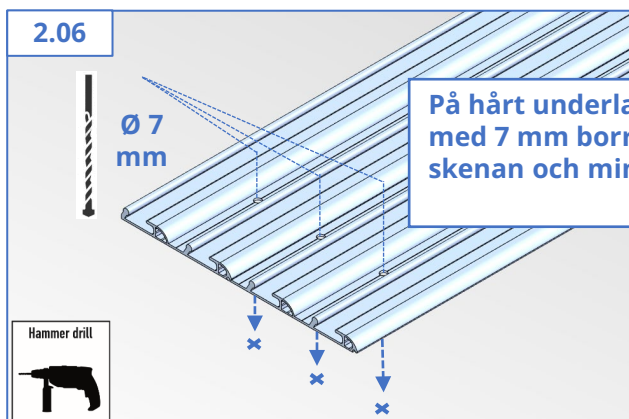

På hårt underlag (ej trä) ska hålen borraras med 7 mm borrhåll och sen 10 mm borrhåll under skenan och minst ett djup på 60 mm

2.07

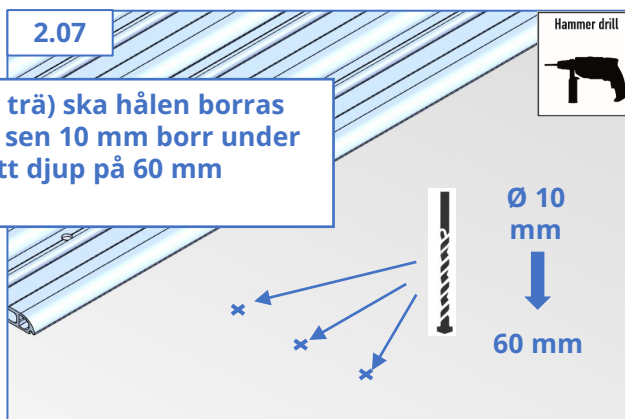

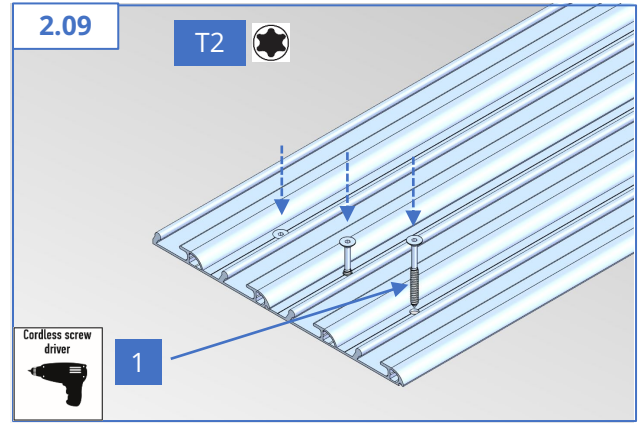
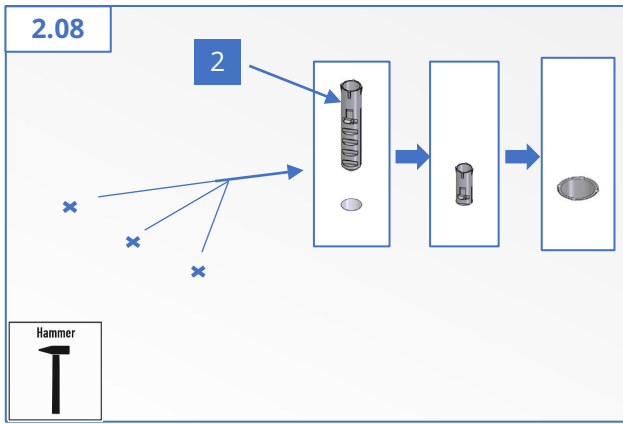

OBS! Fetta alltid in skruvarna

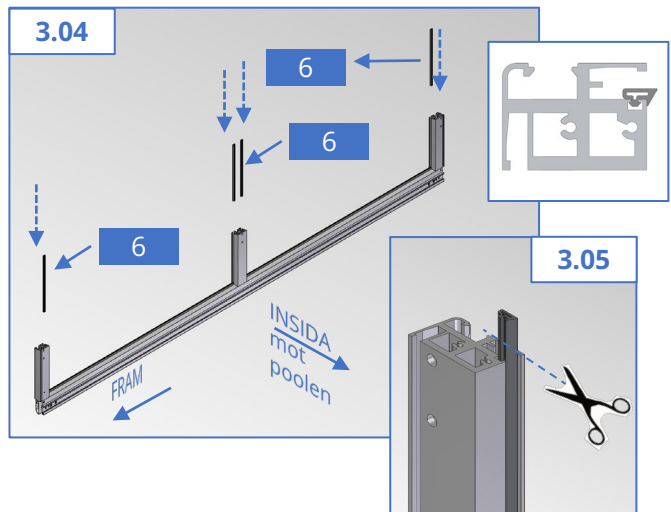
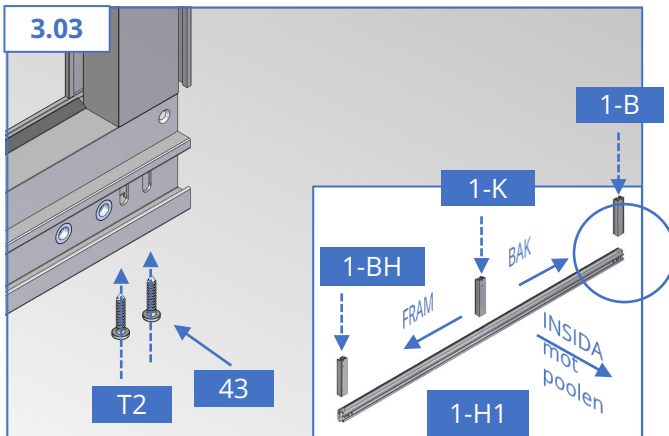
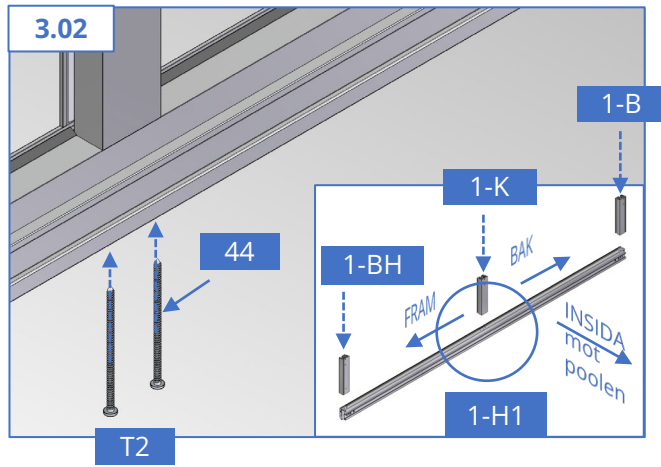
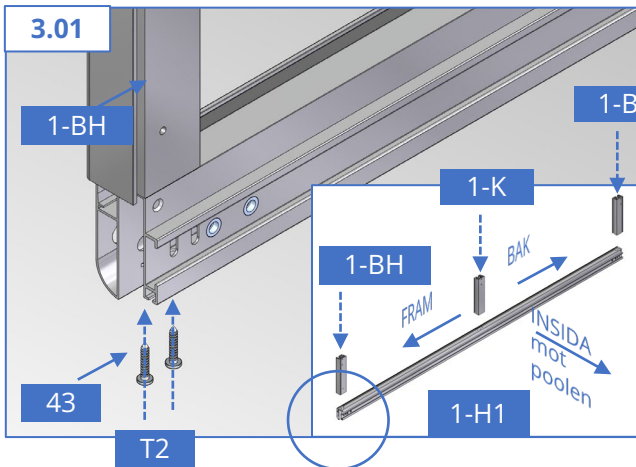

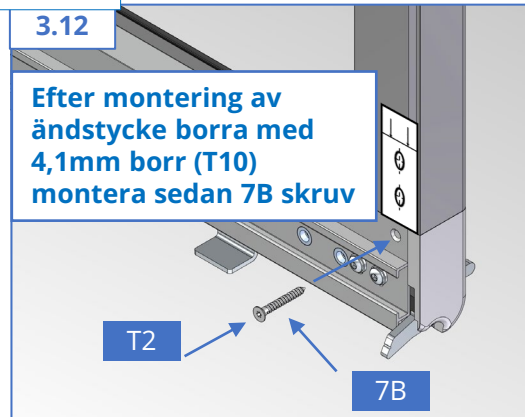
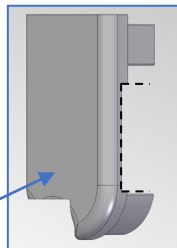
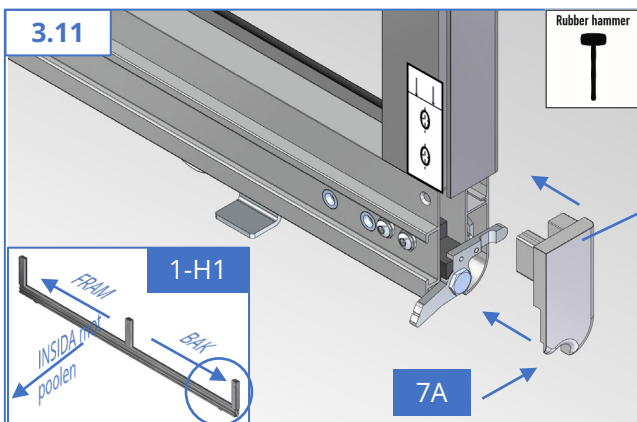
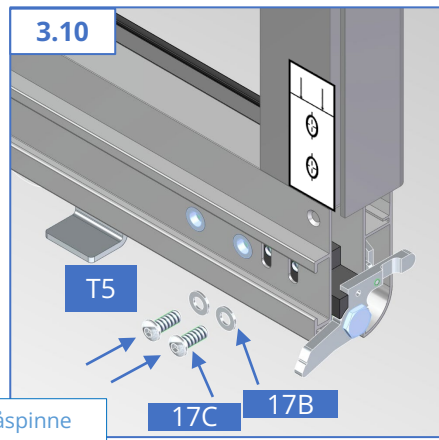
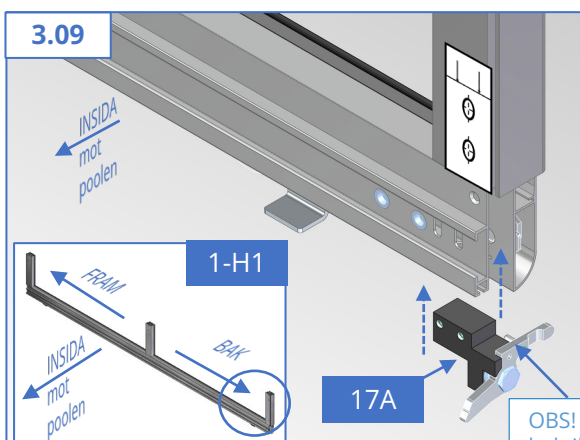
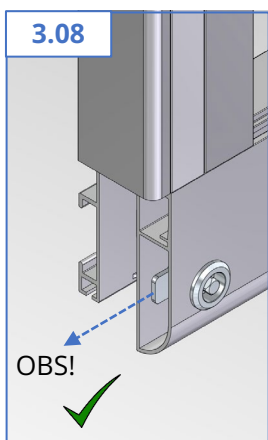
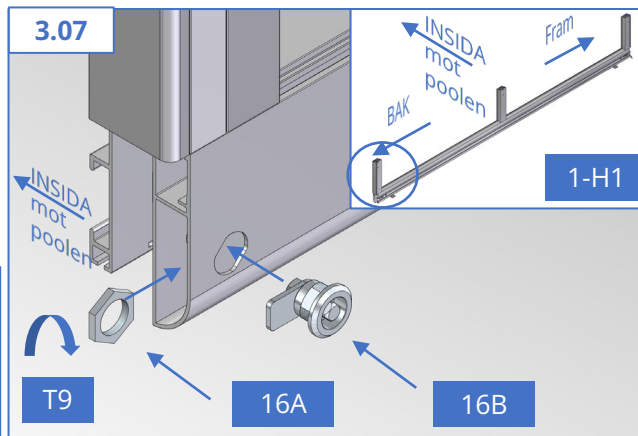
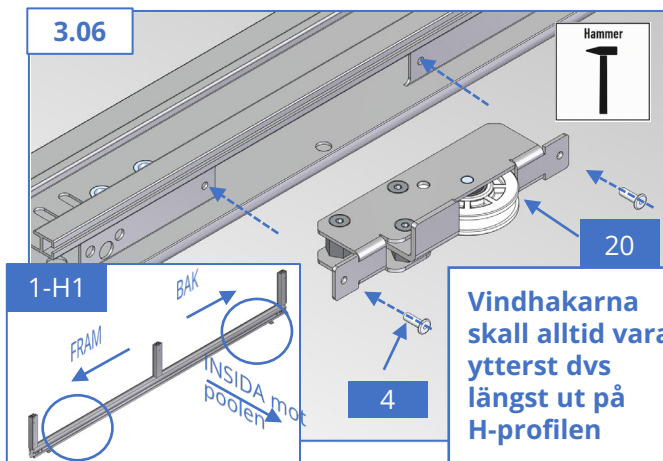

OBS! Bormallens position i bakkant på profil. Markerade hål ska borraras med 4,1mm borrh. Säkerställ att hål borraras genom två väggar då skruven ska gå igenom båda för stabilitet.

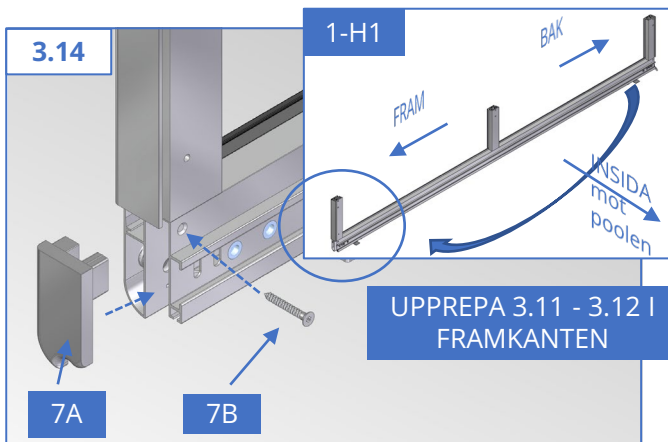
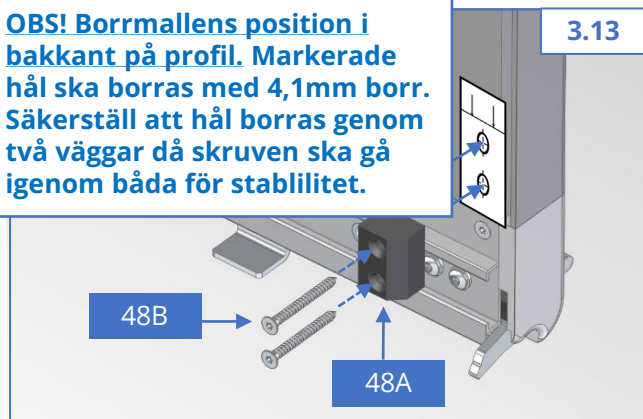

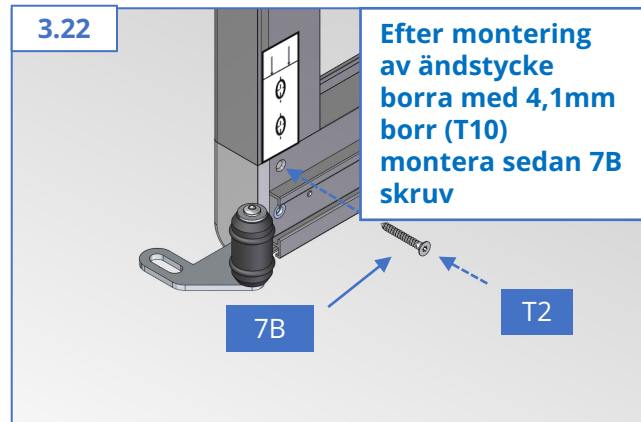
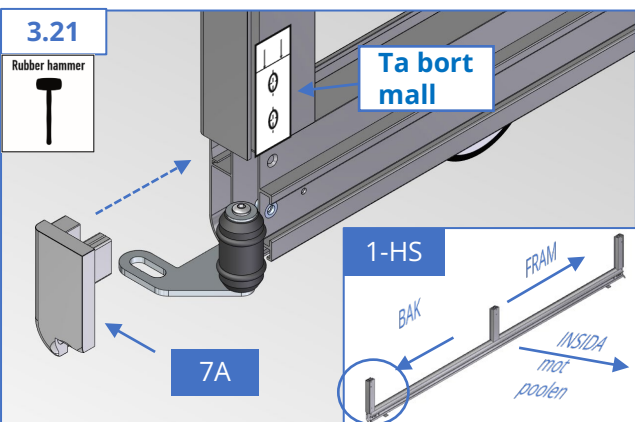
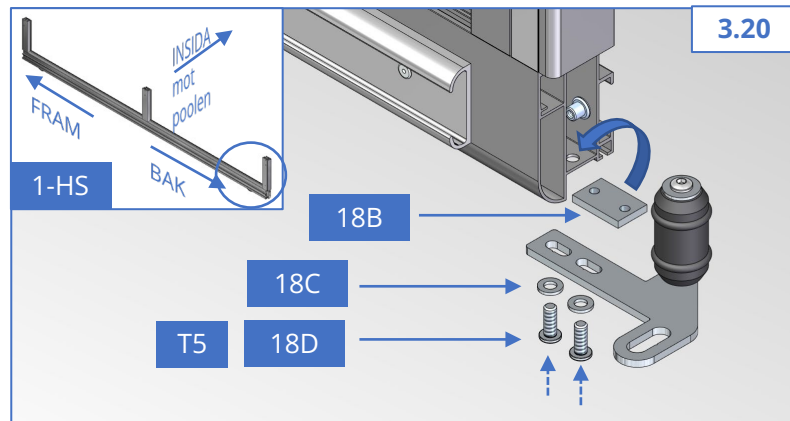
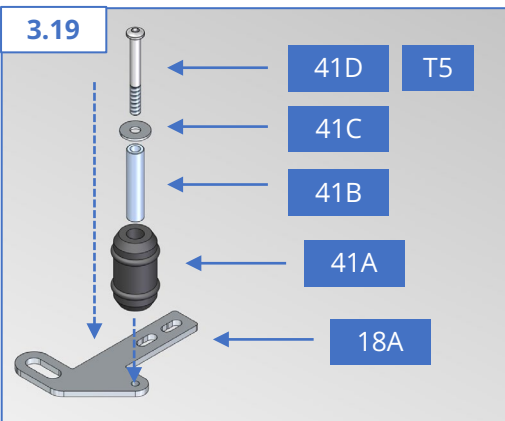
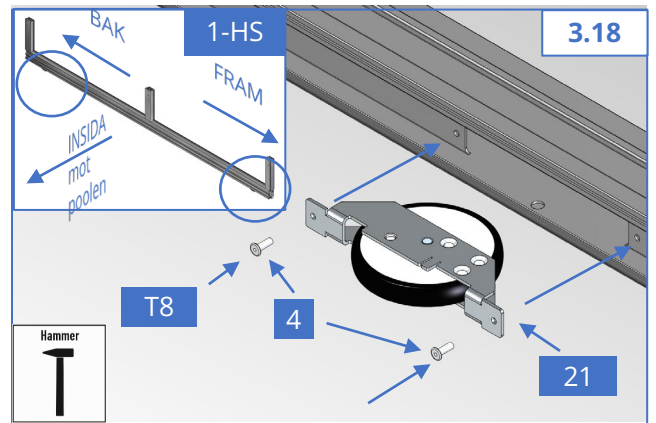
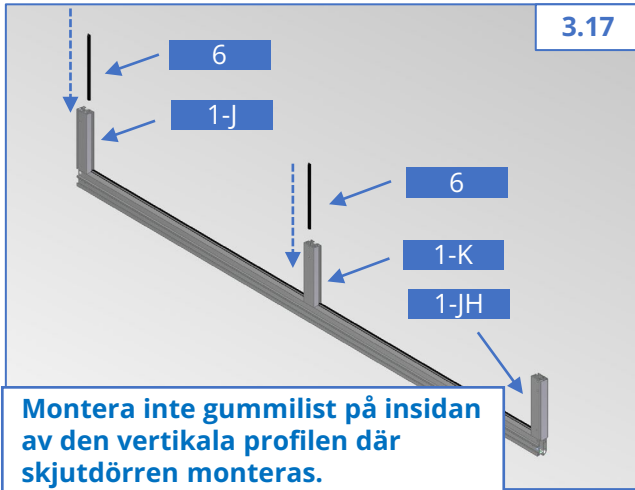
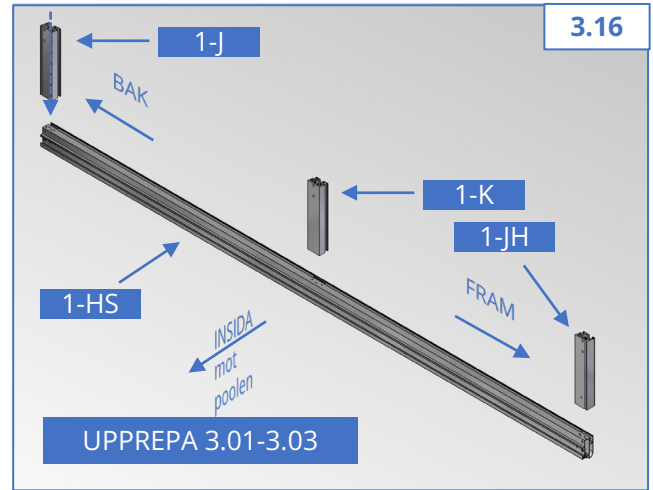
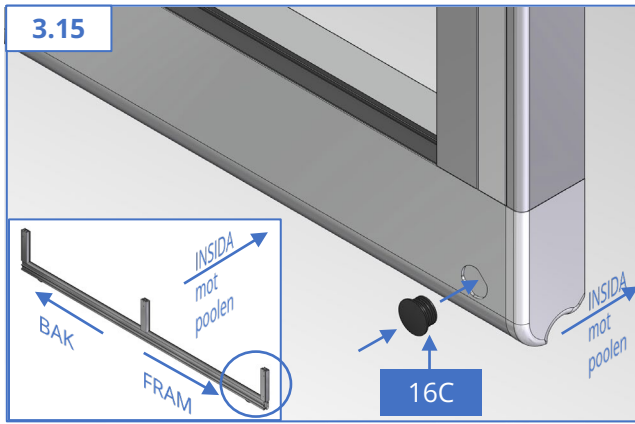

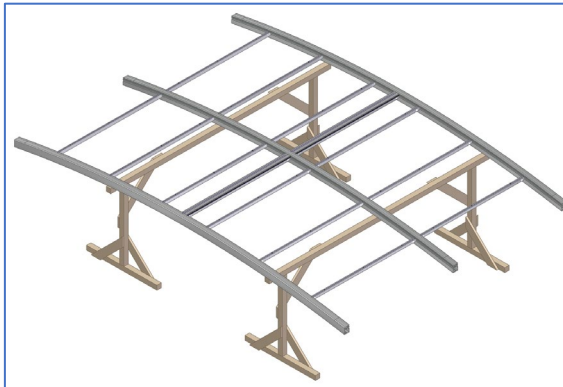
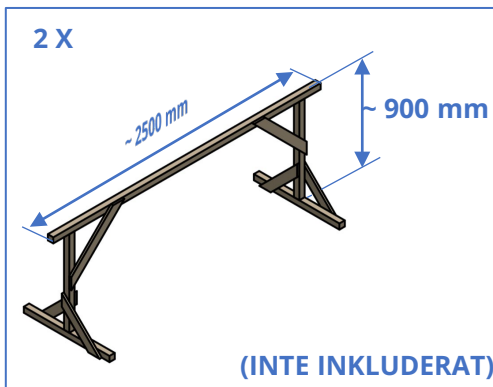
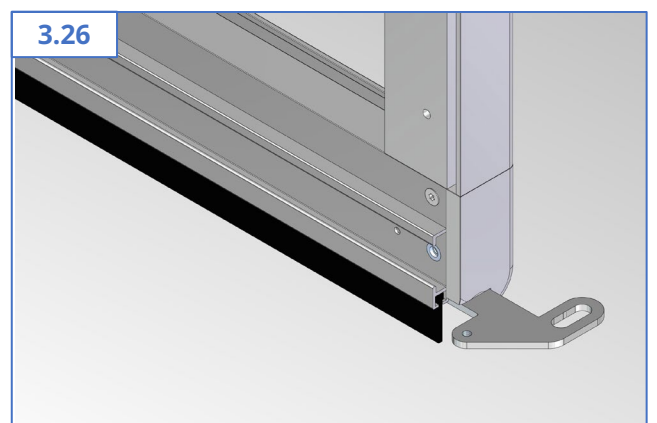
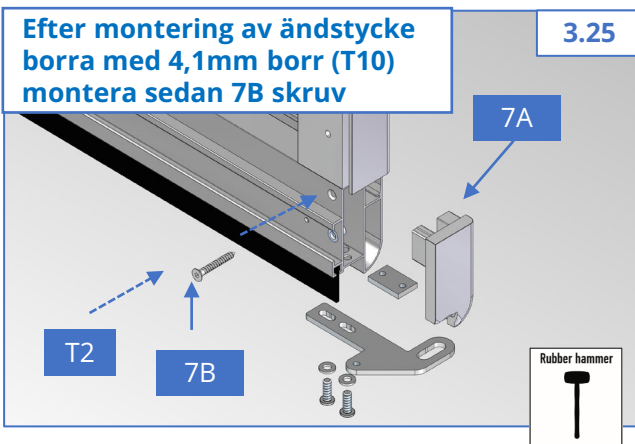
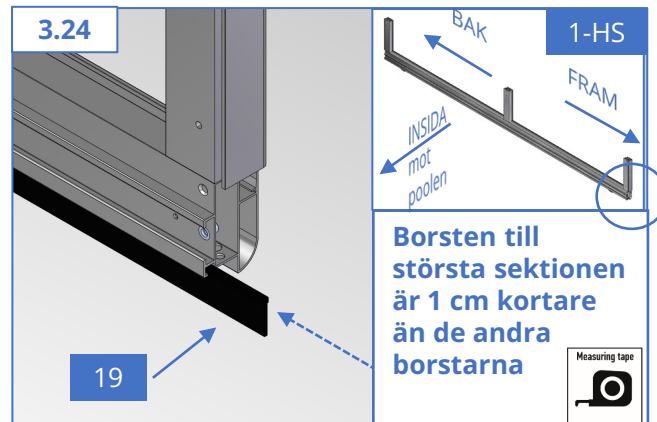
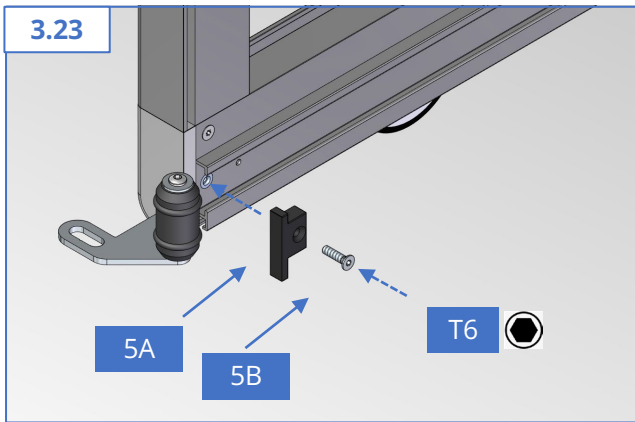

Vi rekommenderar för säkert och ergonomiskt arbete att följande moment utförs på bockar, som inte är inkluderade i boxen!

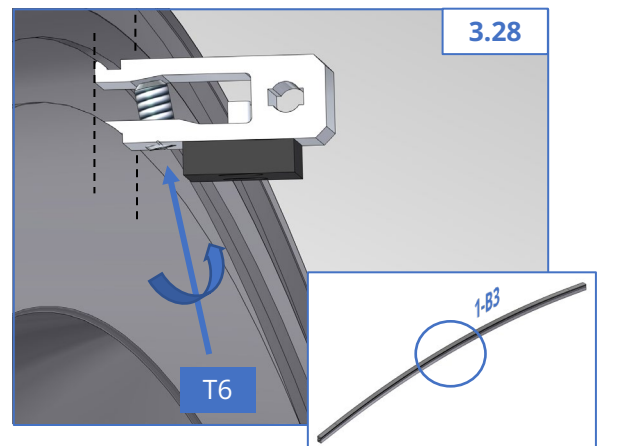
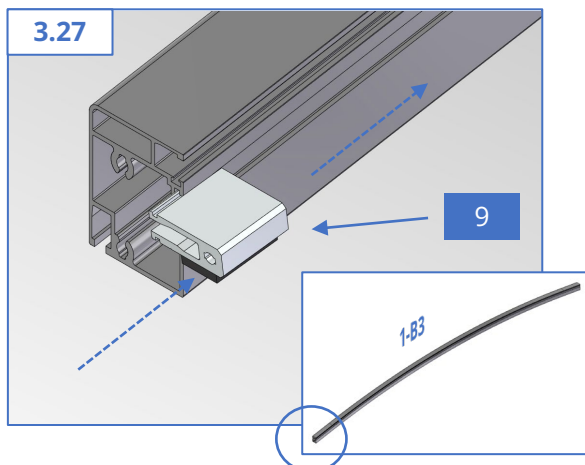



3.29

Leia 3x6 – 3 st / sida
Leia 4x8 med/utan sarg – 4 st / sida

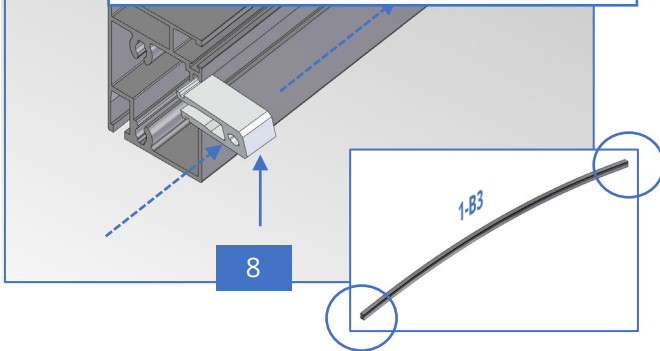

3.30

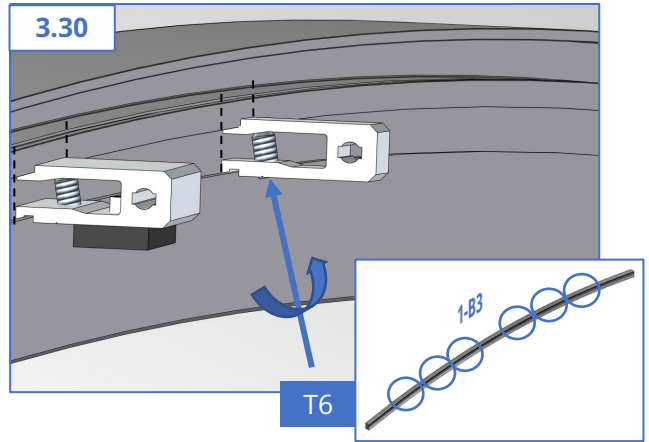

3.31

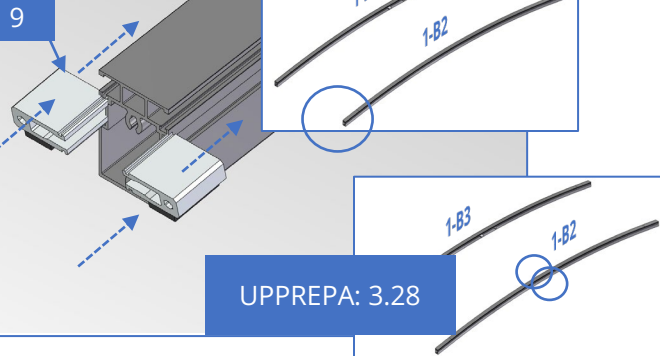

3.32

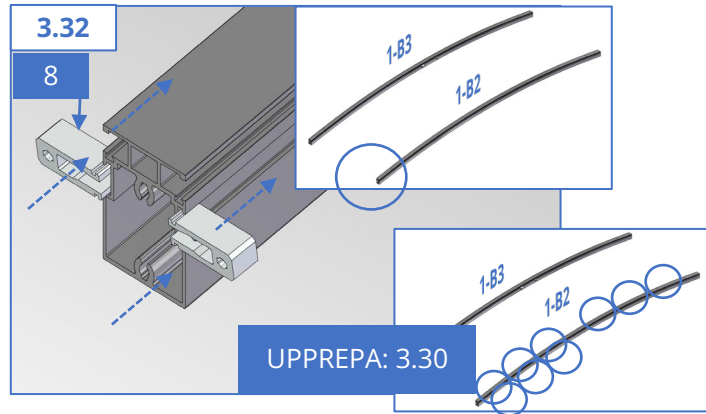

Efterjustera och säkerställ att fästena linjerar mot varandra i bågprofilerna

3.33

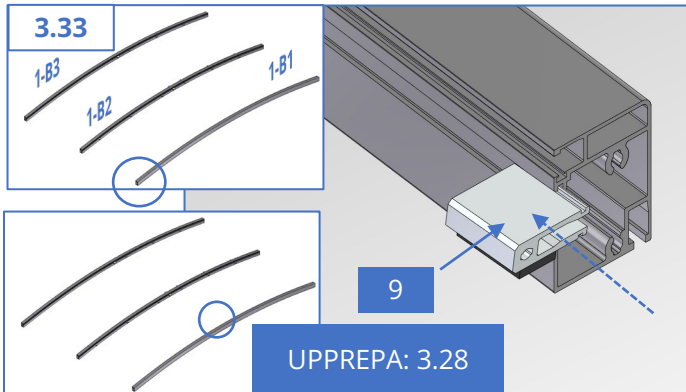

3.34

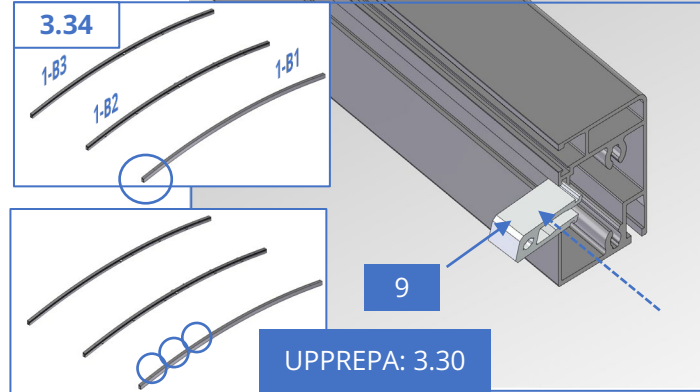

3.35

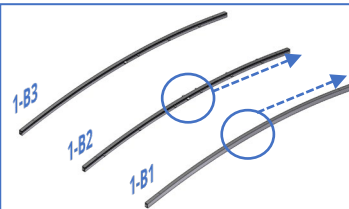
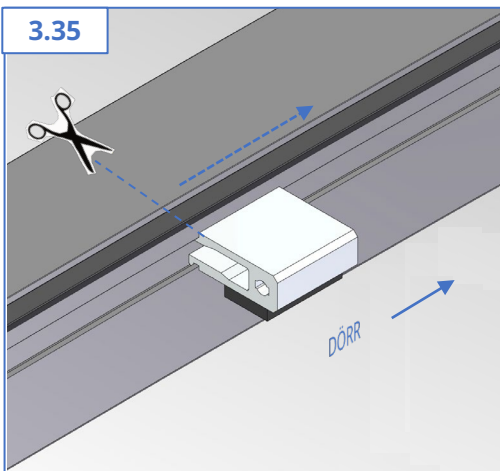

Klipp av insidans
gummilist (nr 6) och ta
bort det från profilen
1-B1 och 1-B2 där
skjutsdörren monteras.

3.36

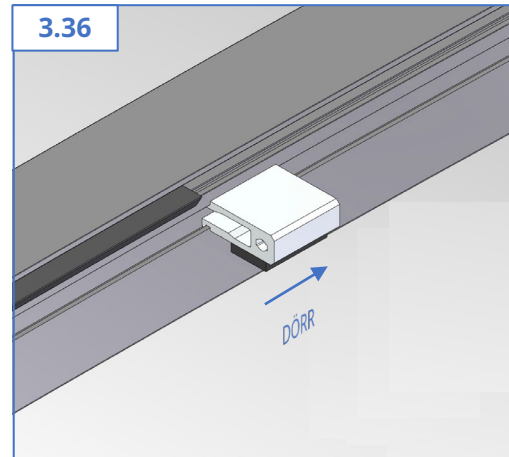

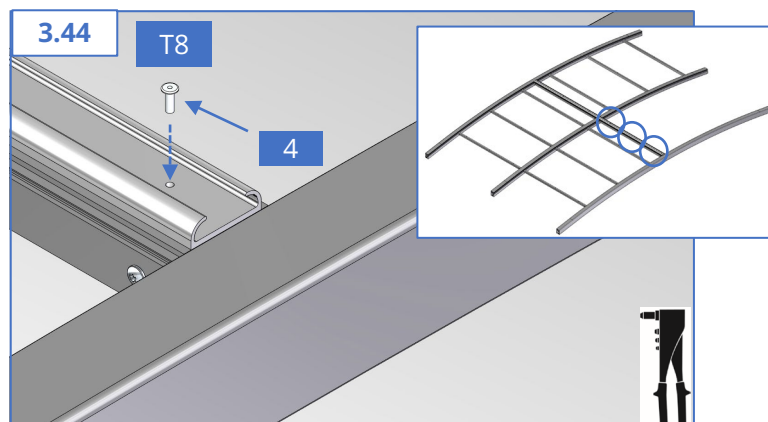
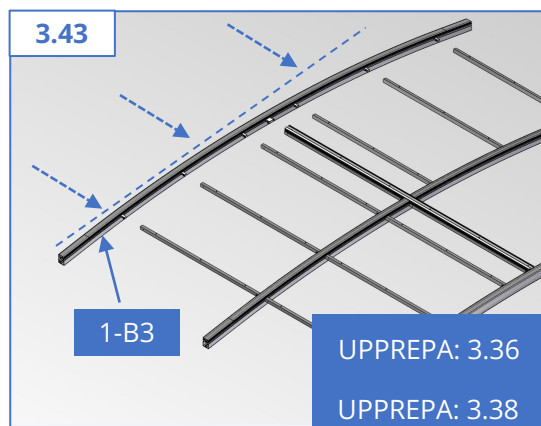
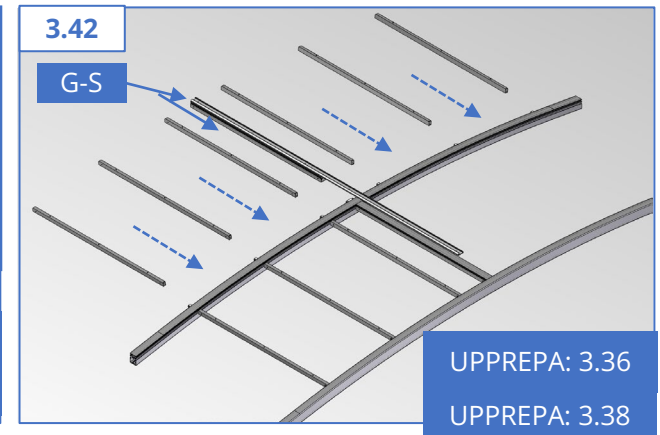
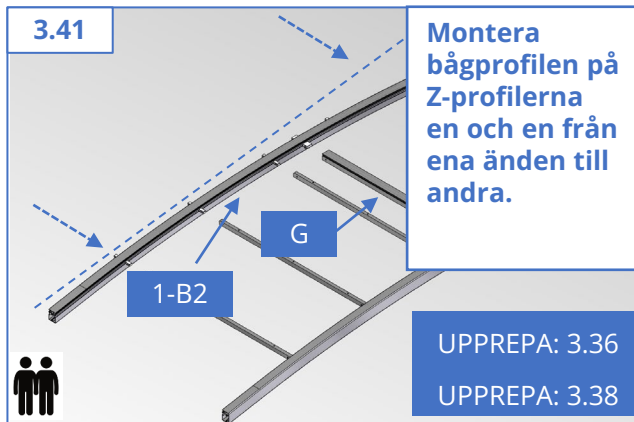
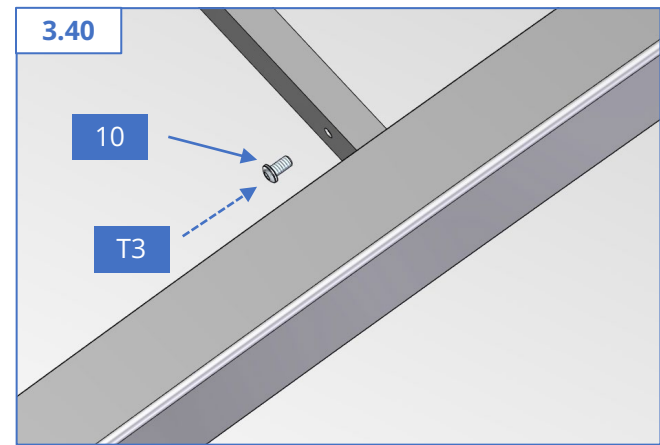
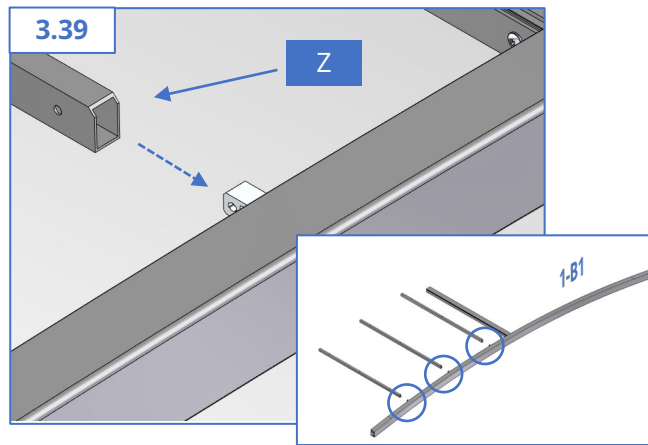
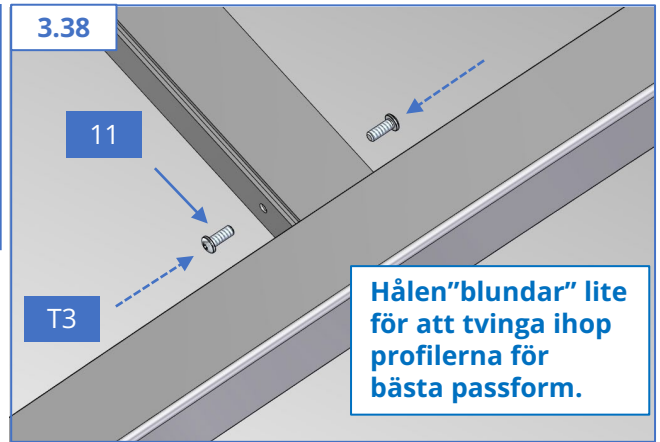
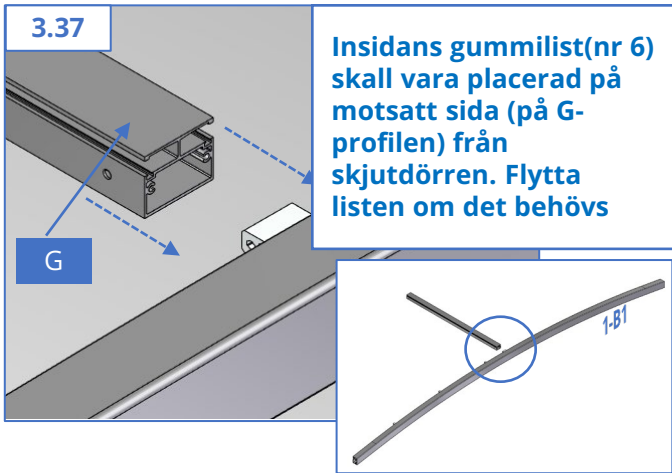

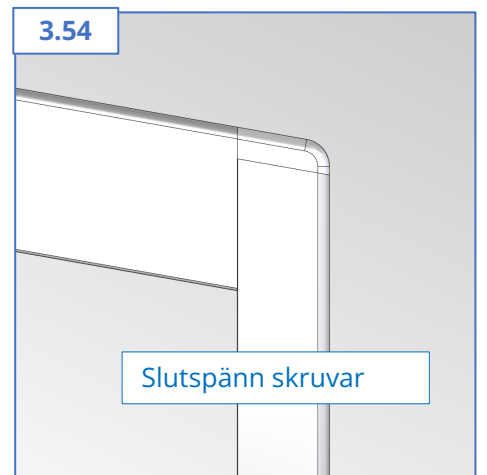
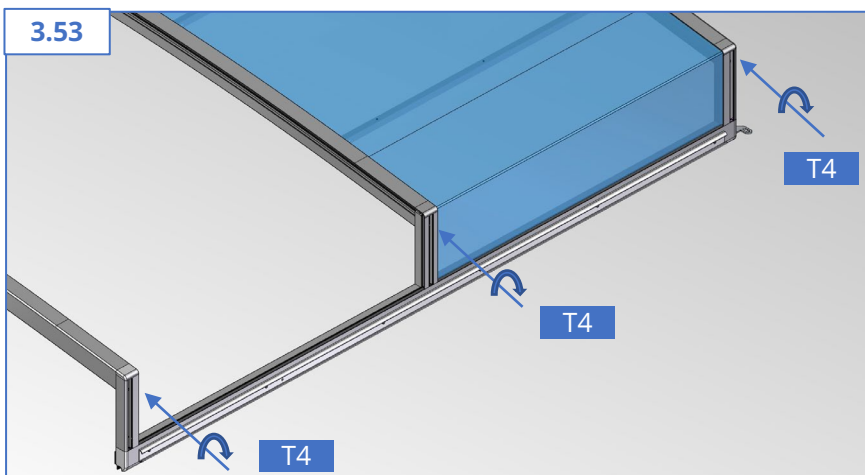
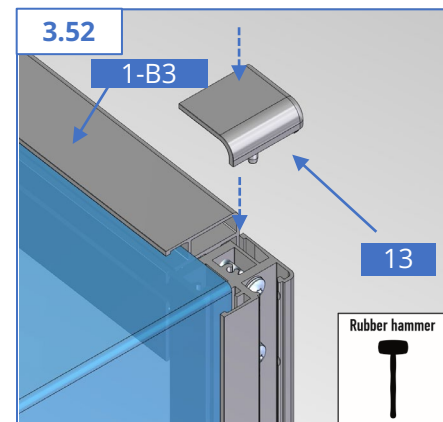
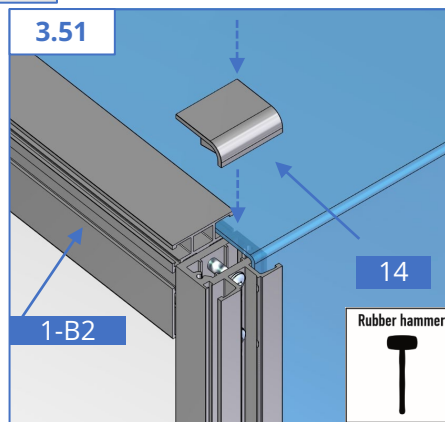
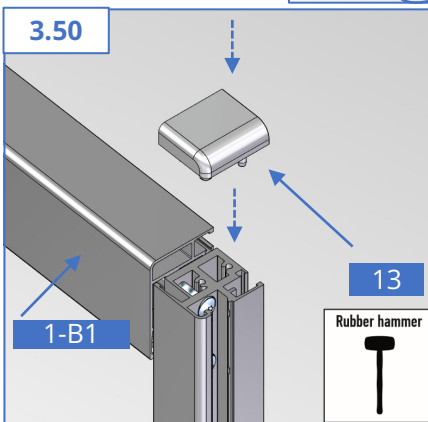
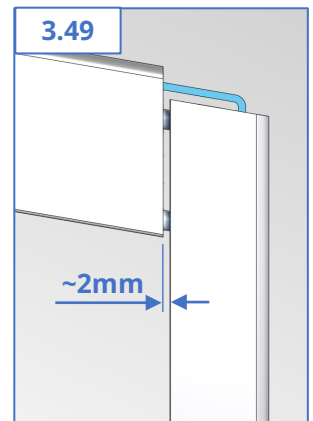
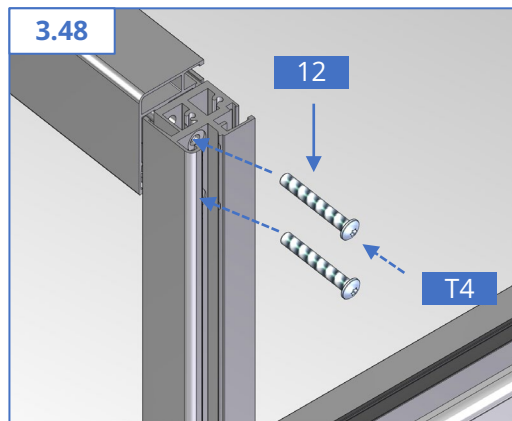
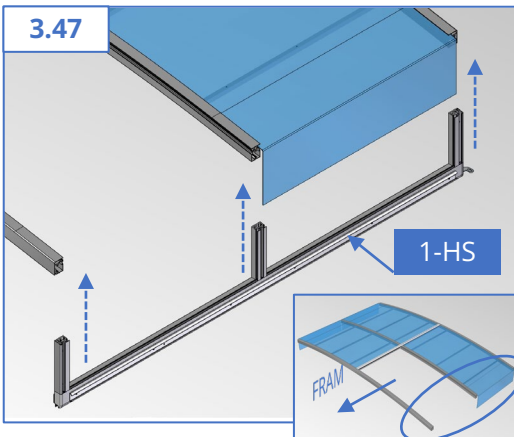
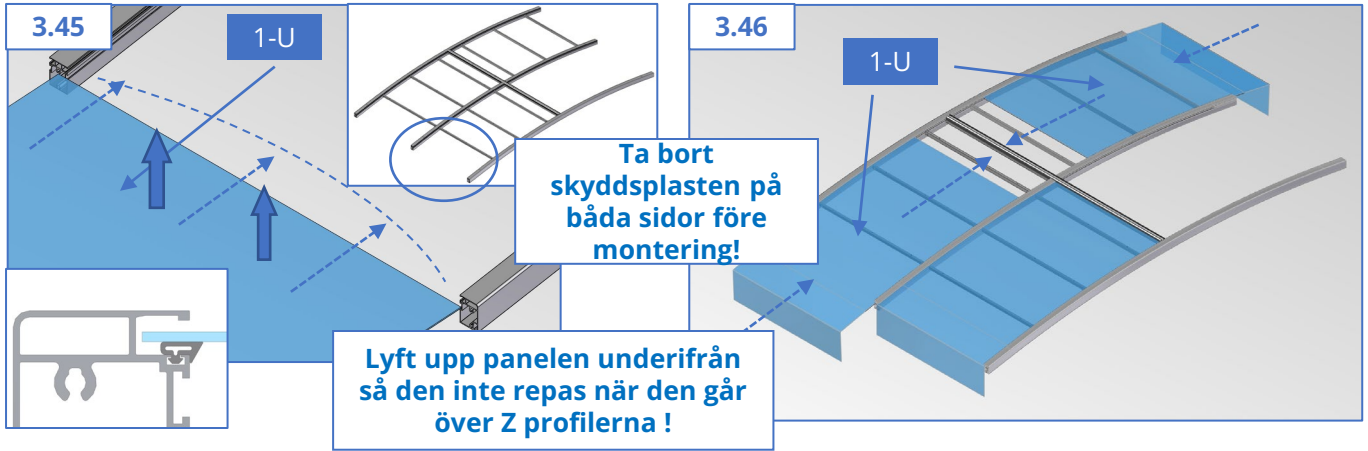

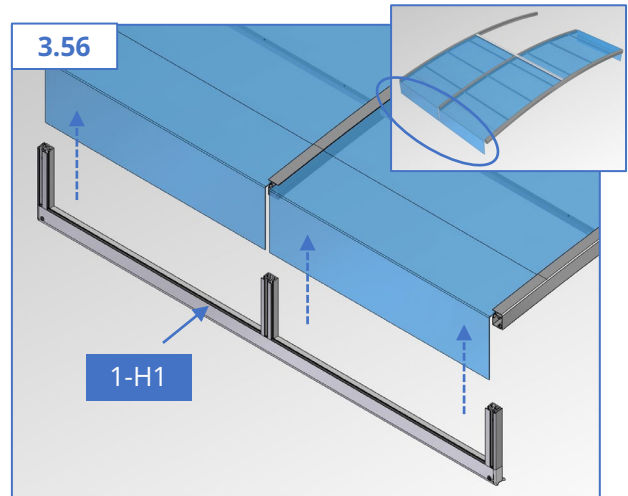
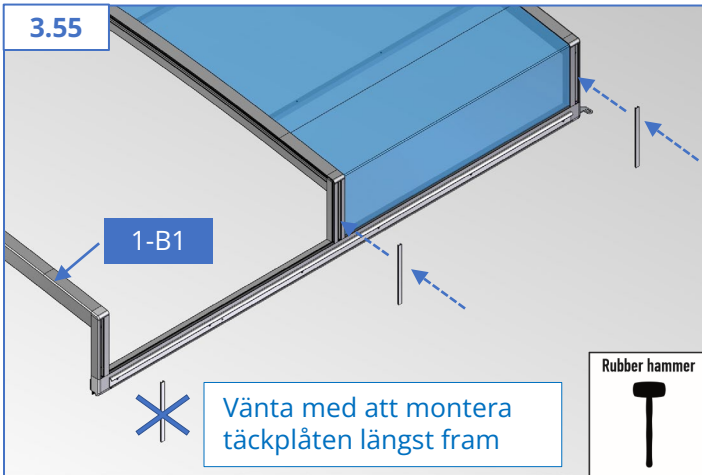

UPPREPA: 3.45 – 3.56

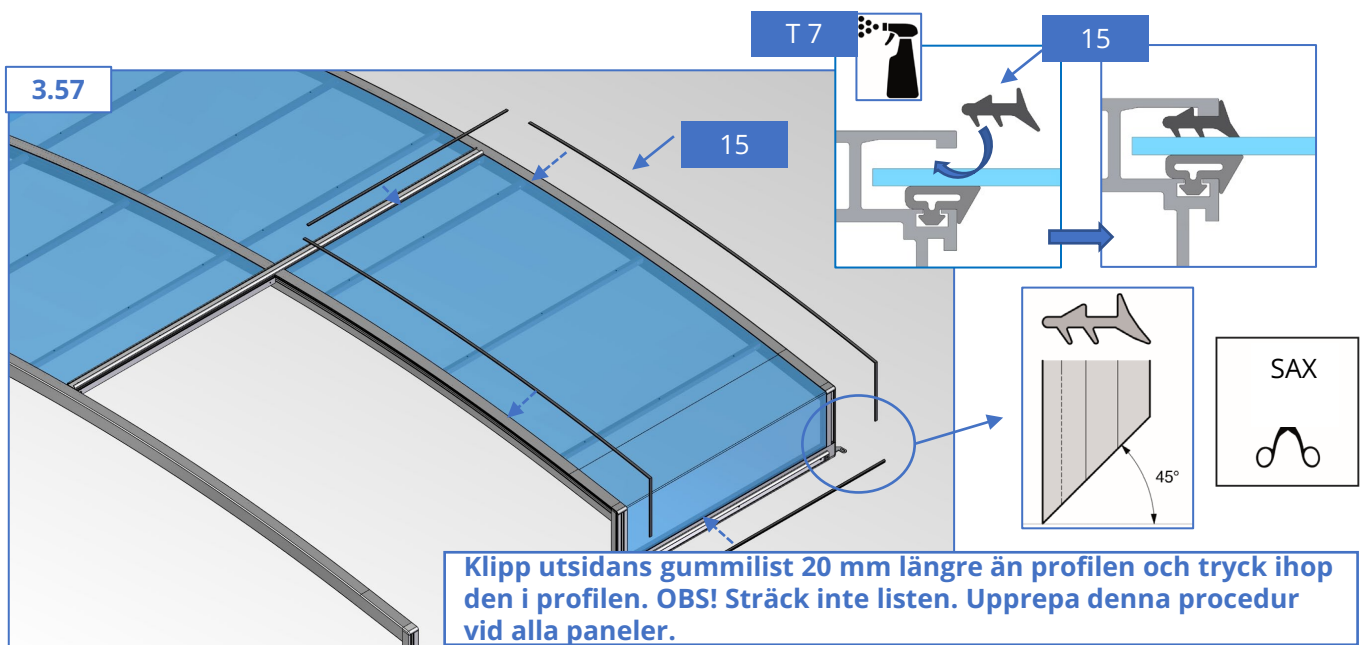

Kör på största sektionen på skenan först därefter de övriga sektionerna i fallande storleksordning

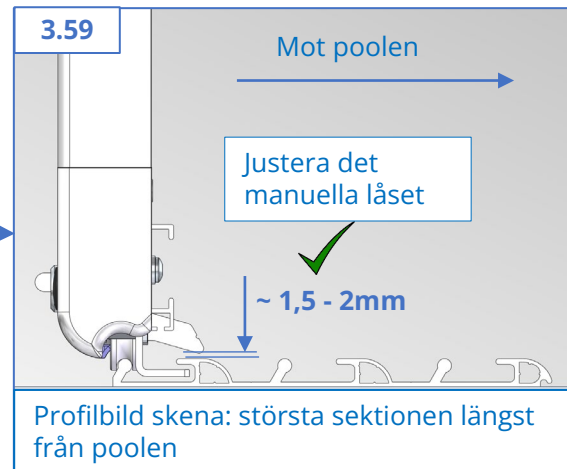
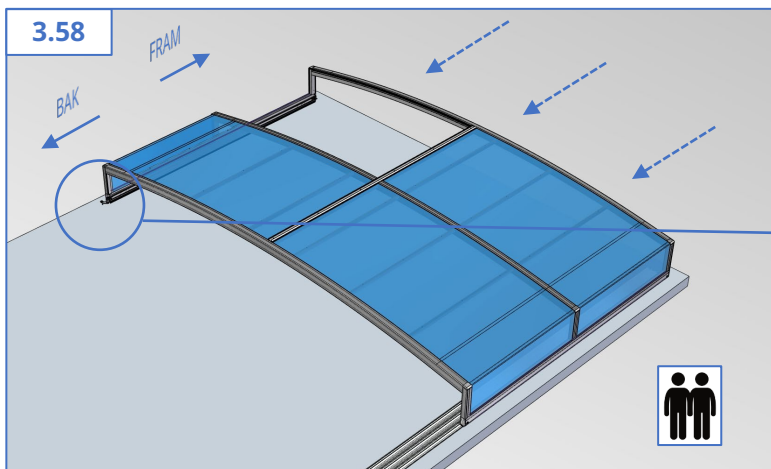



X*= Vilken sektion räknat från den största
Ex. andra sektion = 2-K

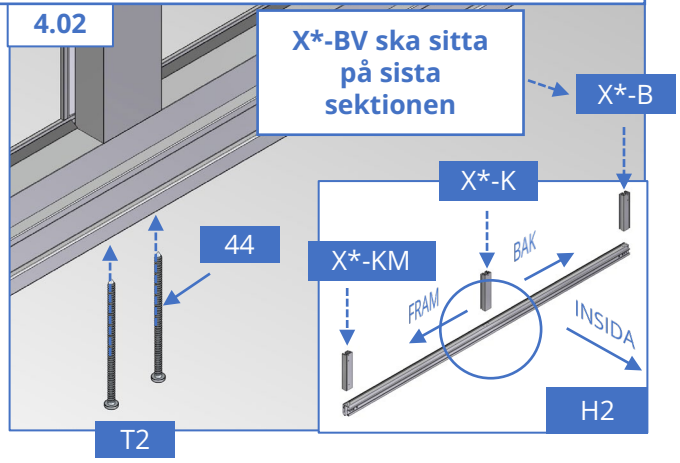
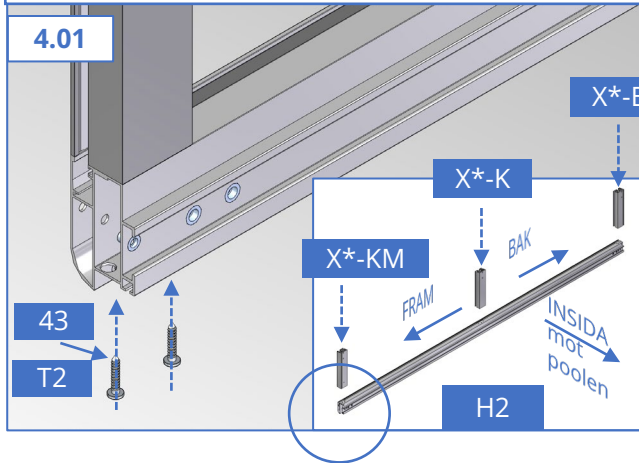

OBS! Säkerställ att X*KM profilen på **skensidan** har bormallen på utsidan längst fram

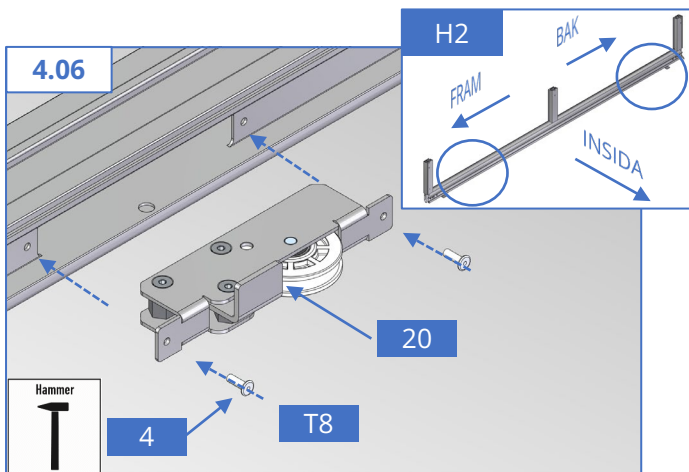
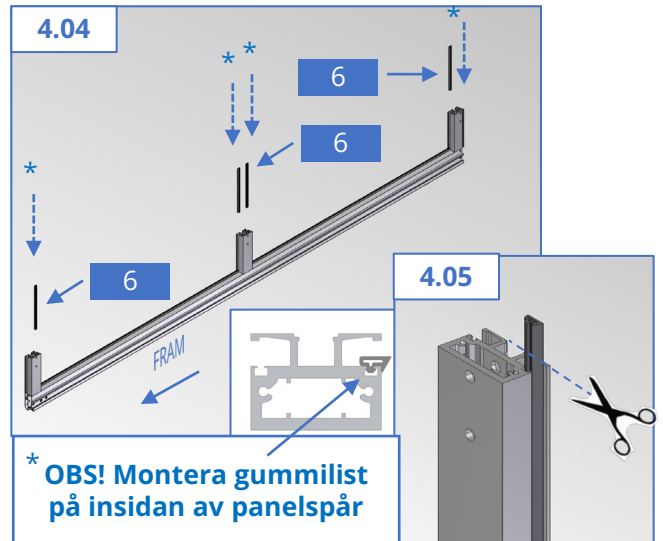
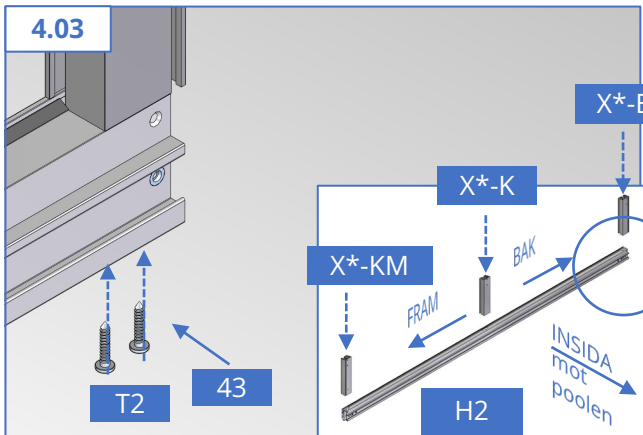

Vindhakarna skall alltid vara ytterst dvs längst ut på H-profilen

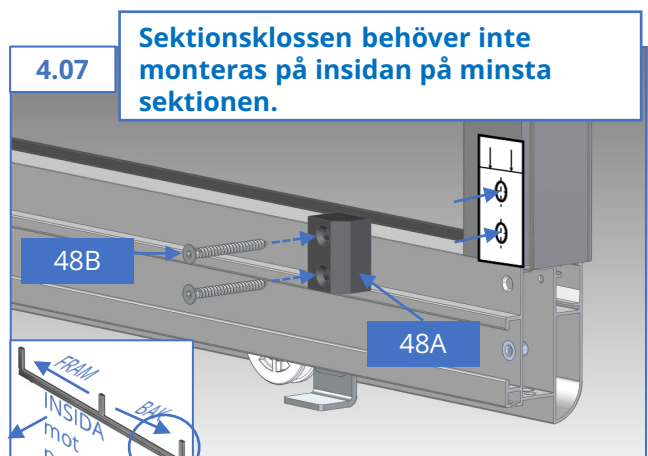

OBS! Mallens position i bakkant på profil insida. Markerade hål ska borraras med 4,1mm borrar. Säkerställ att hålet borraras genom två väggar då skruven ska gå igenom båda. Sektionsklossen behöver inte monteras på insidan på minsta sektionen

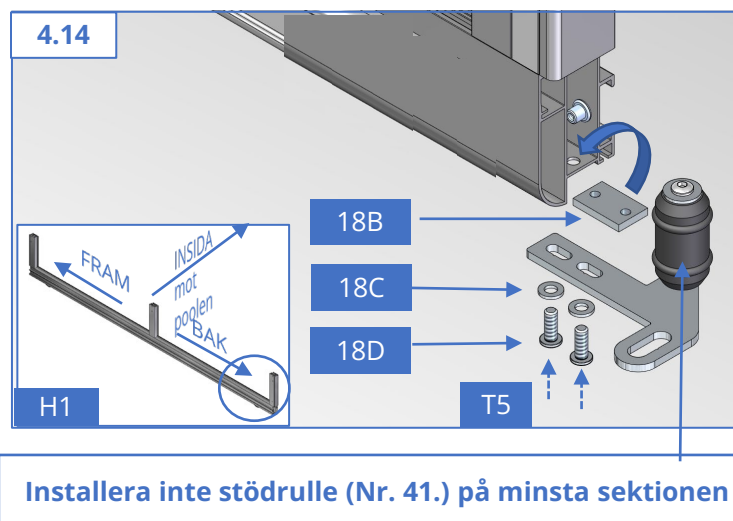
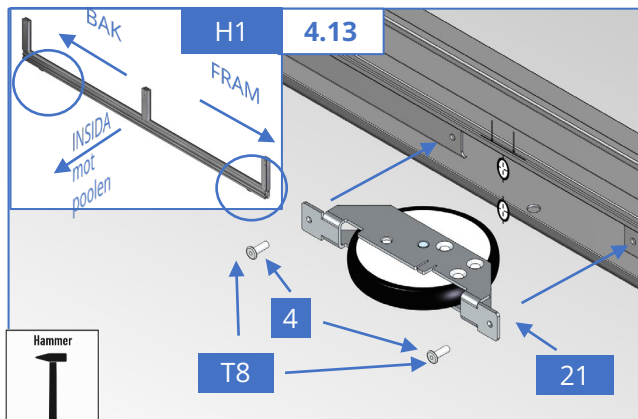
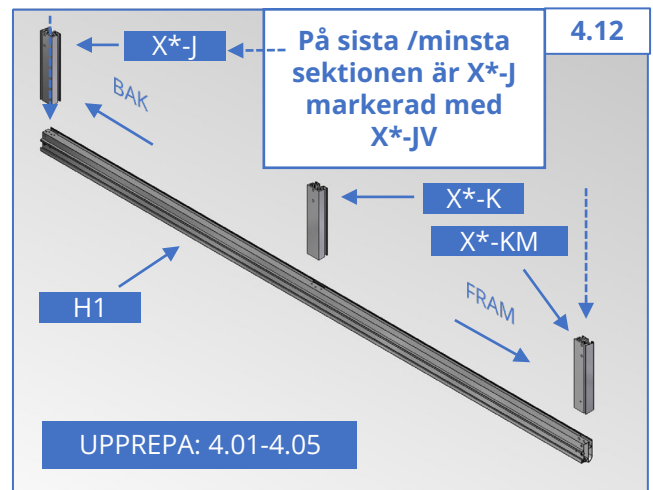
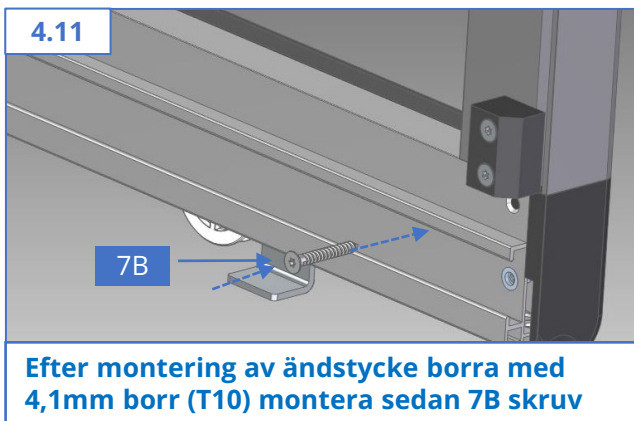
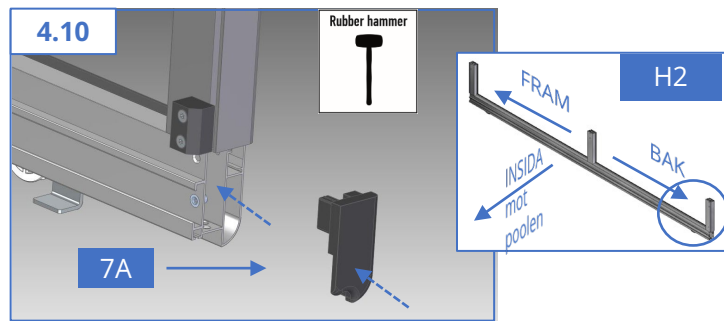
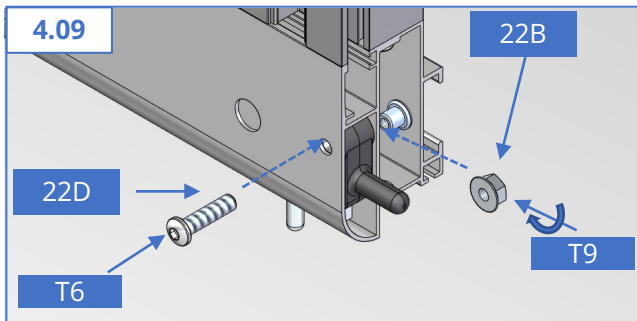
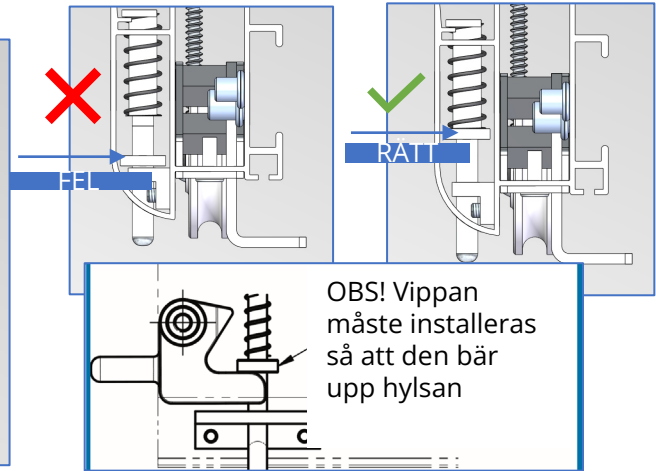
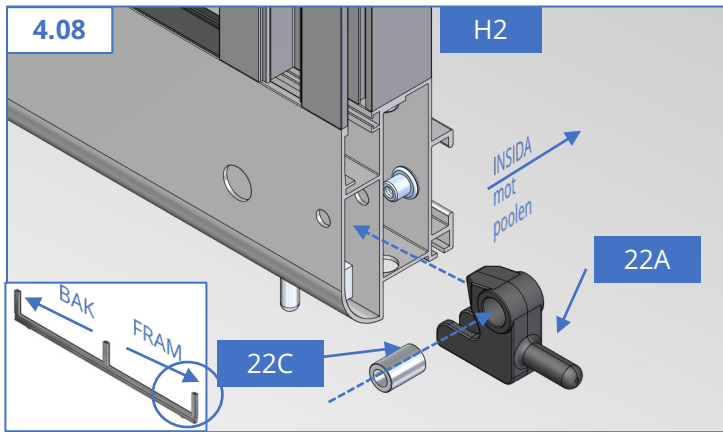

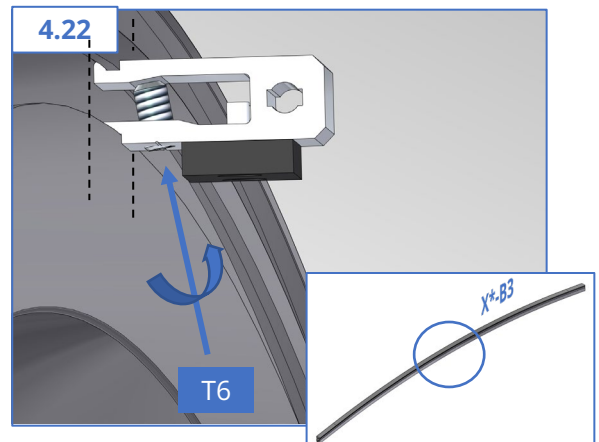
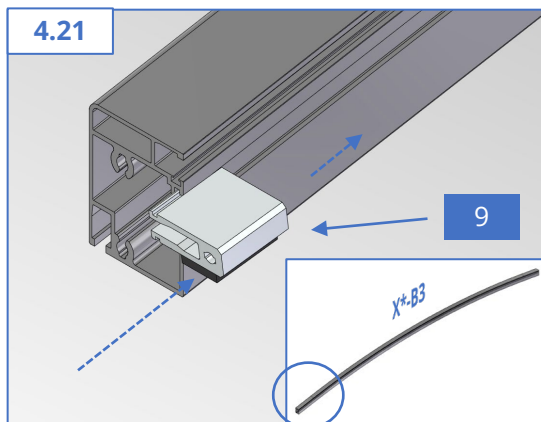
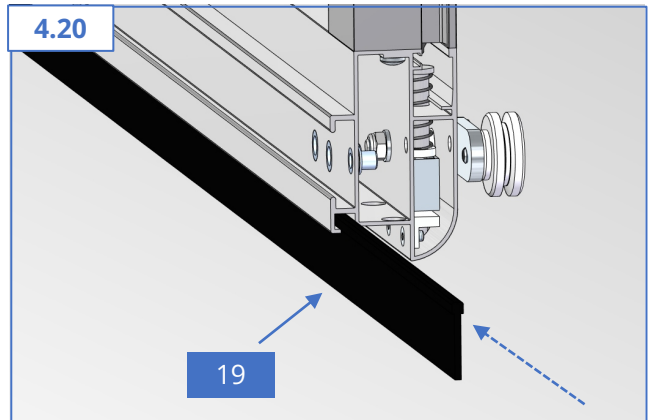
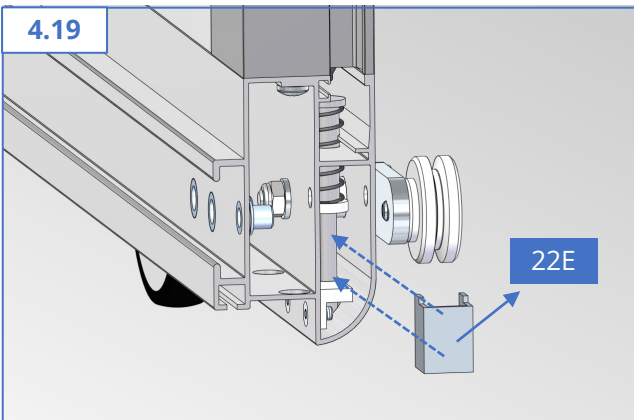
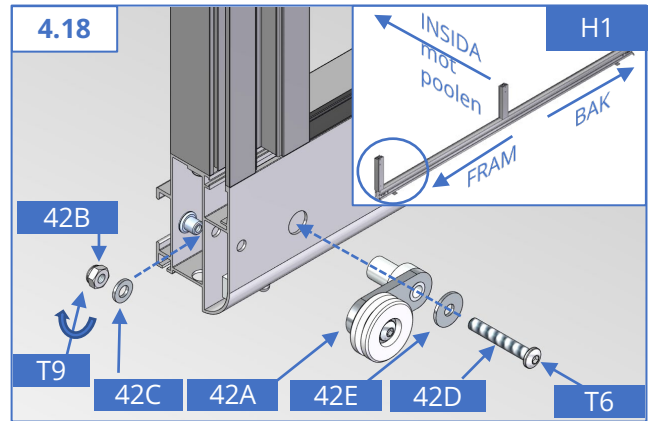
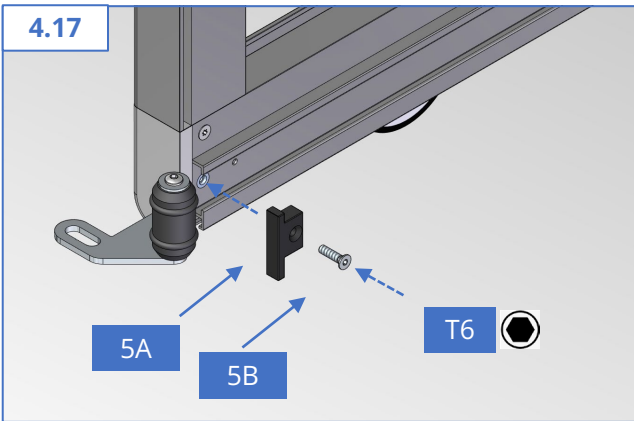
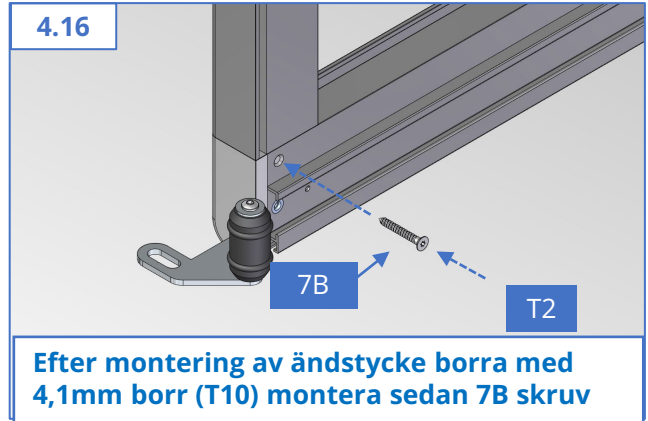
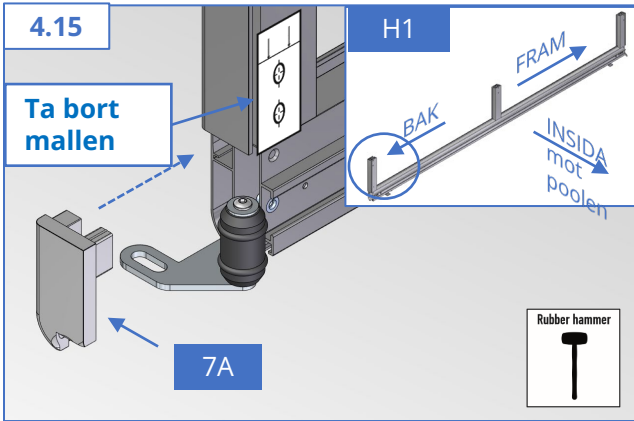

X*= Vilken sektion räknat från den största Ex. 2. sektionen = 2-B3



4.23 Leia 3X6- 3 st / sida
Leia 4X8 med/utan sarg- 4 st / sida

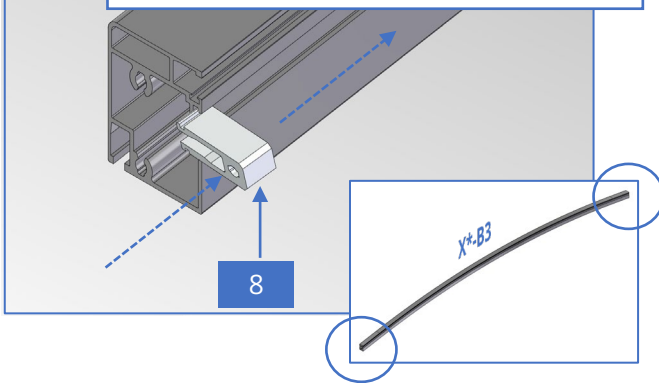

4.24

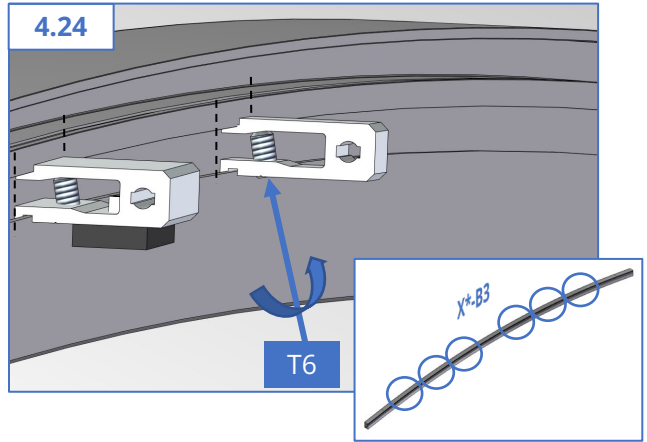

4.25

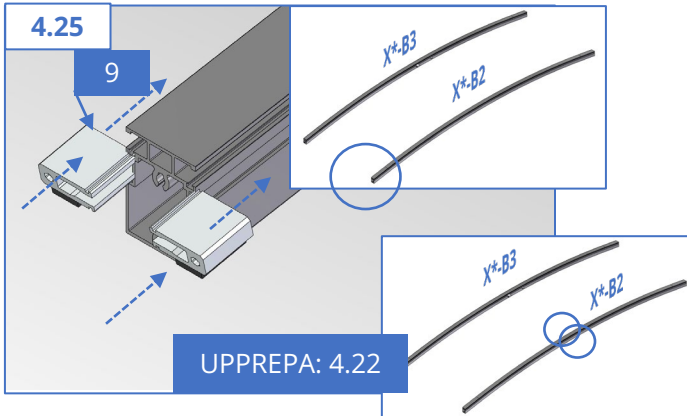

4.26

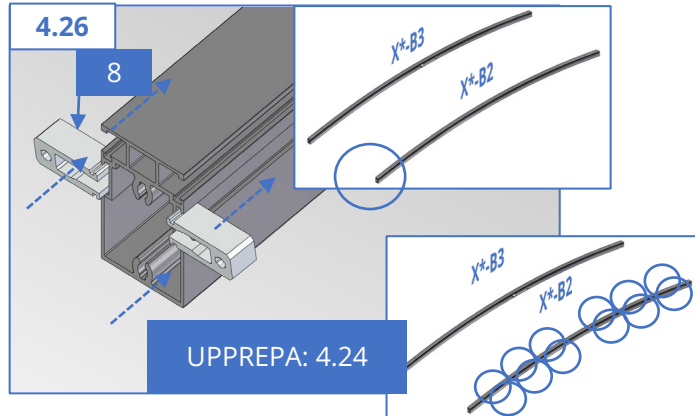

4.27

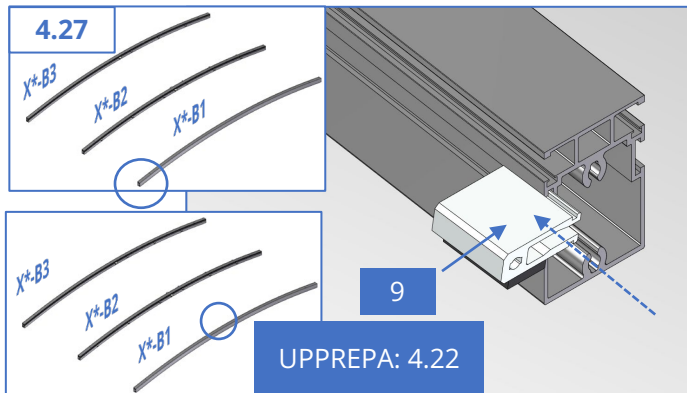

4.28

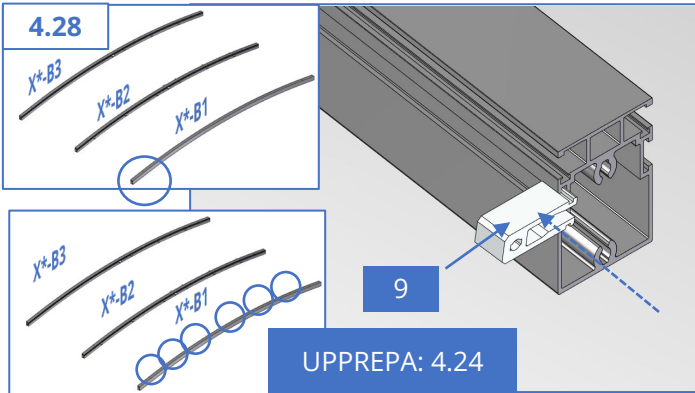

4.29

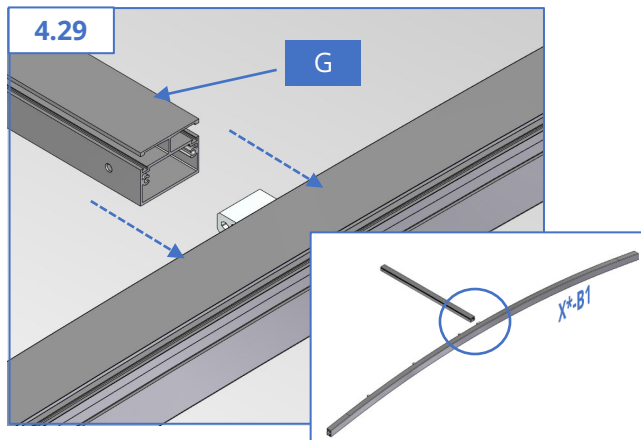

4.30

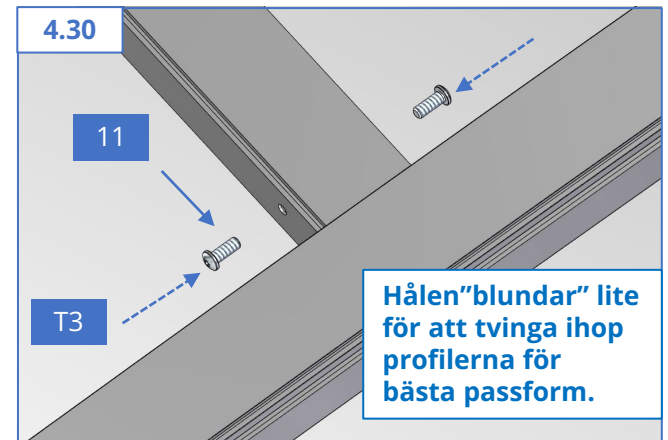

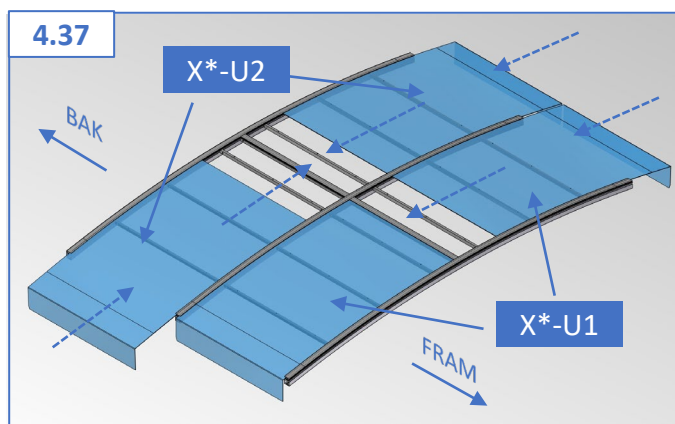
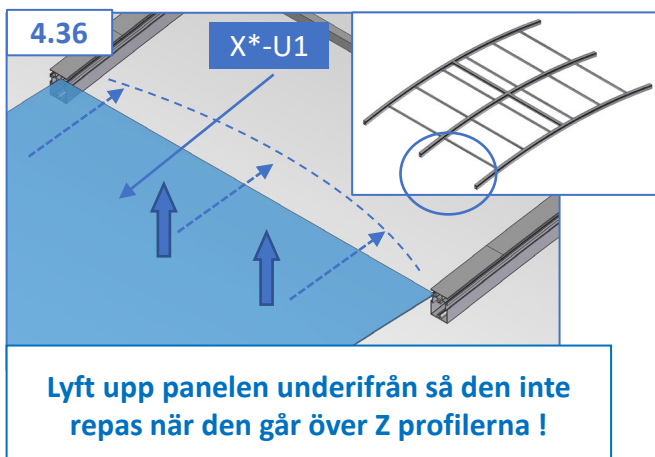
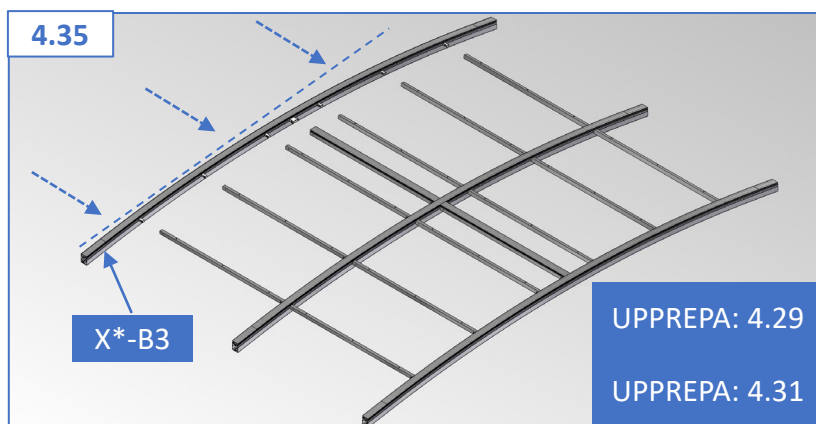
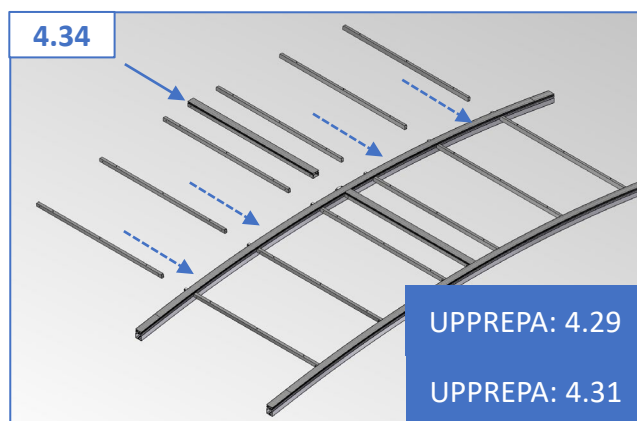
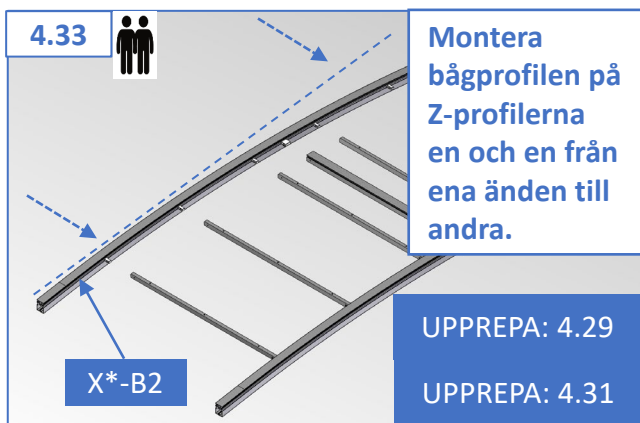
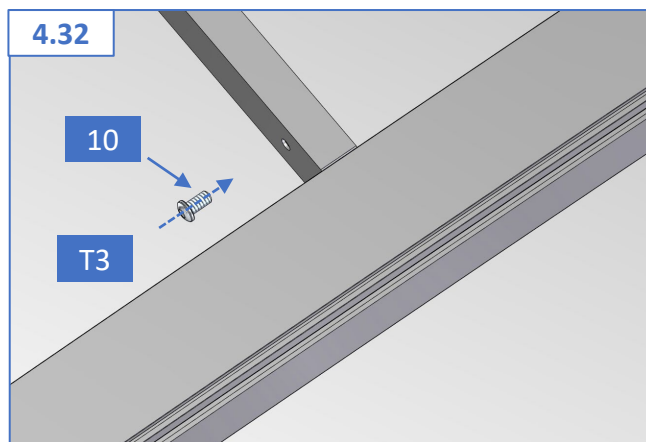
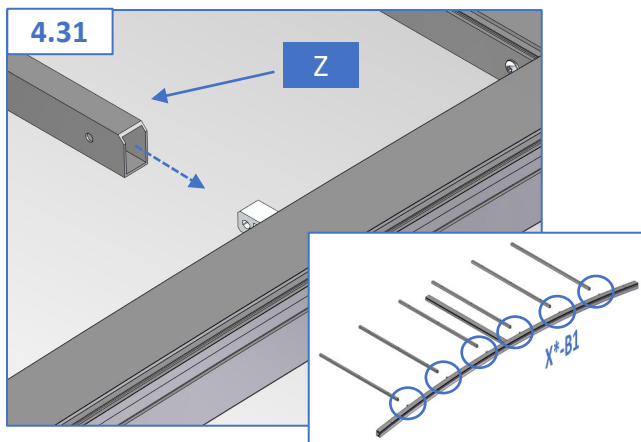

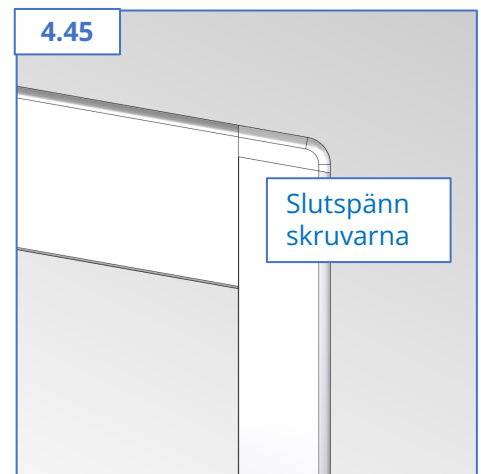
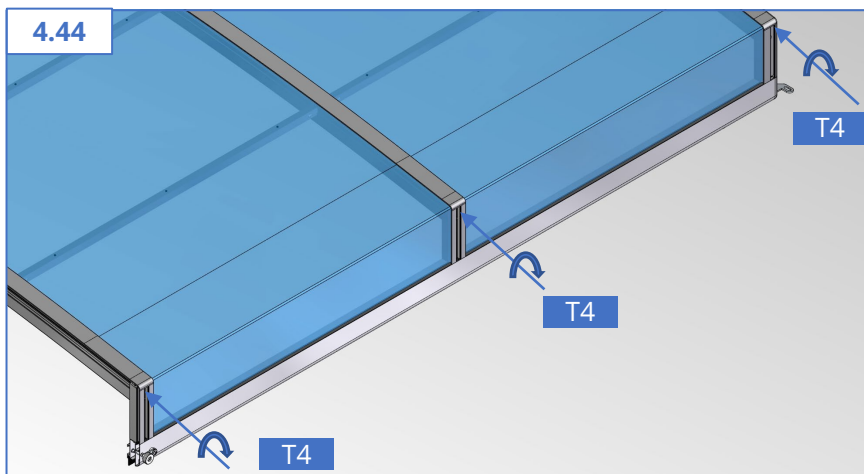
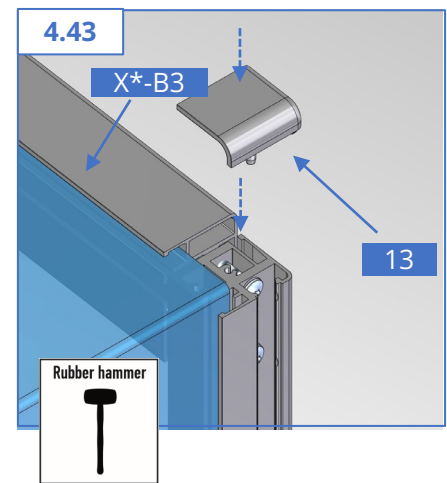
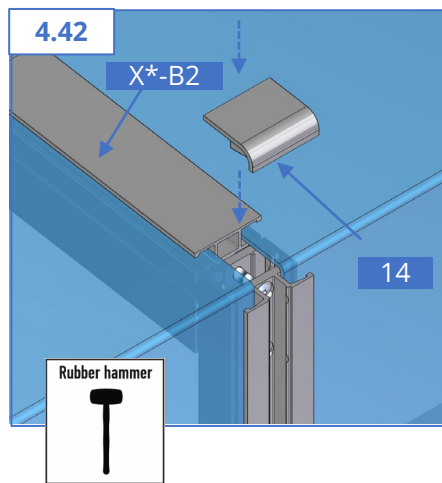
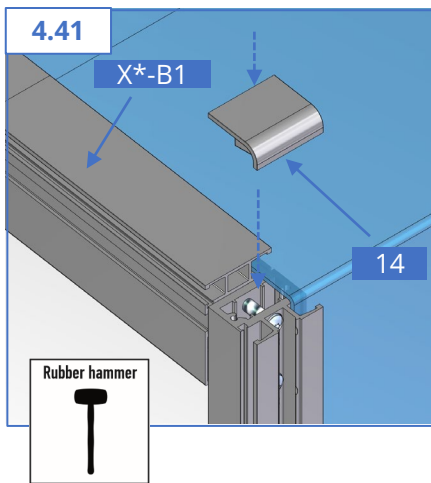
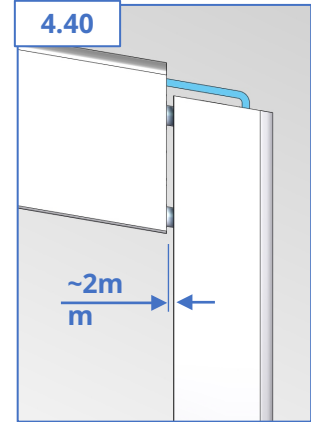
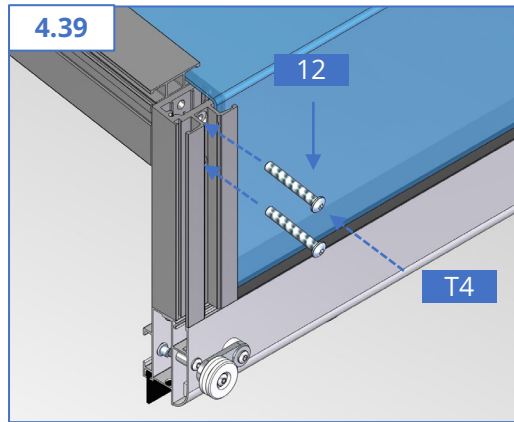
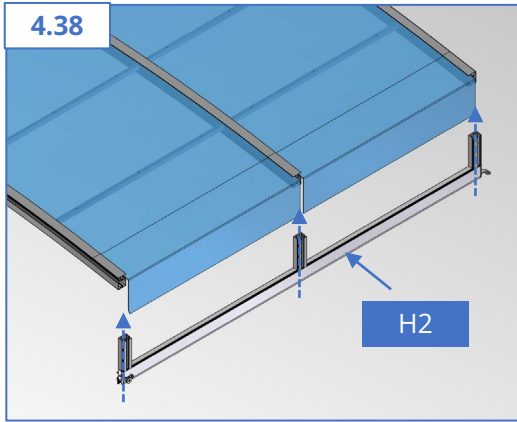

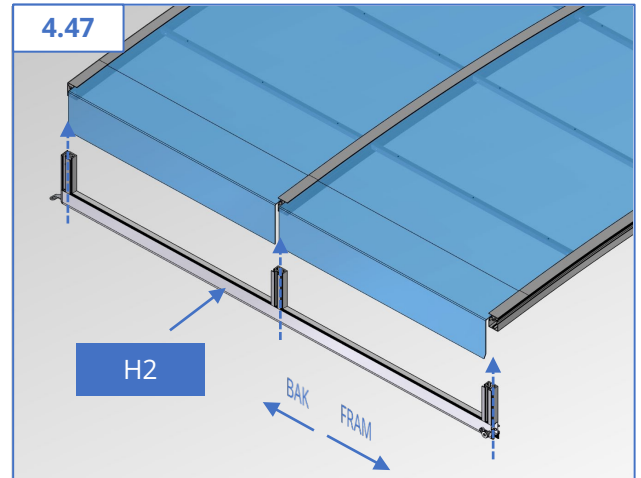
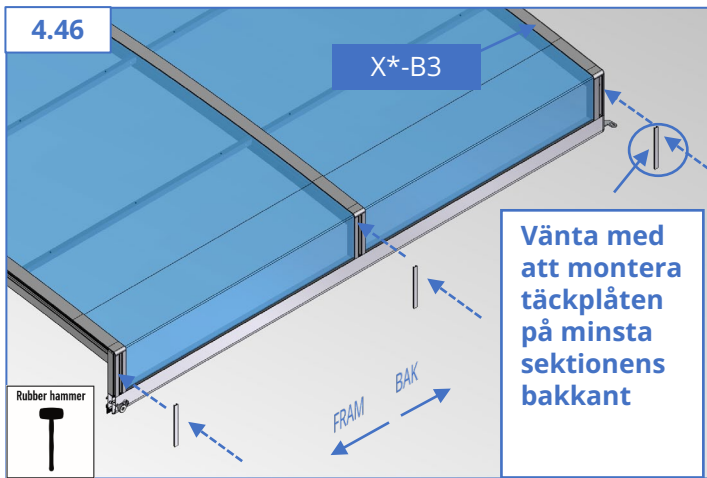

UPPREPA: 4.39 – 4.46

Montera gummilist utsida på samtliga sektioner enl bild 3.54

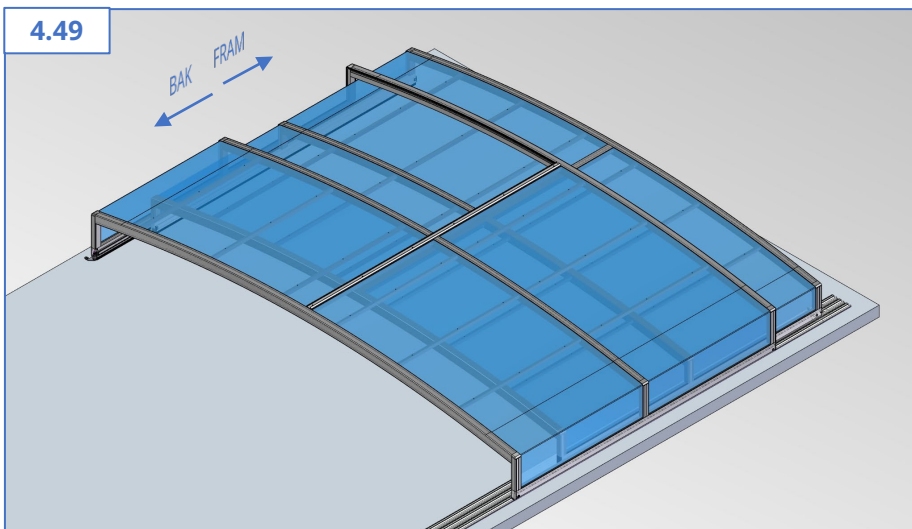
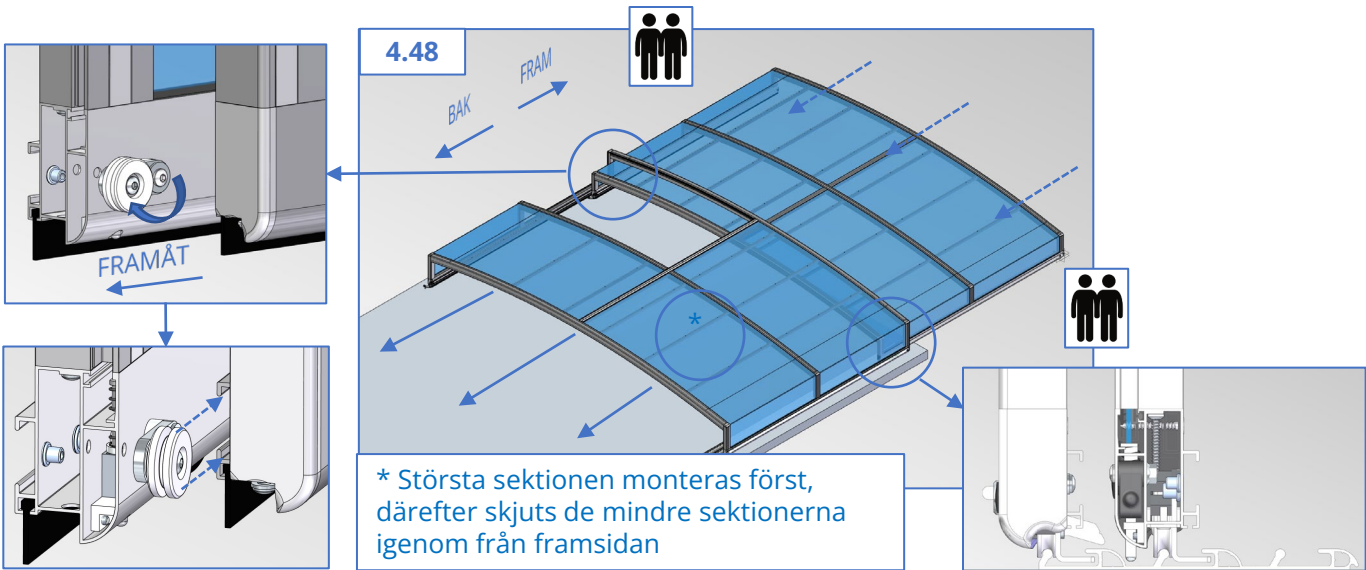

Montera samtliga mellansektioner enligt 4.01 – 4.48

Observera följande punkter vid montering av den minsta sektionen 4.02, 4.07, 4.14, 4.46.

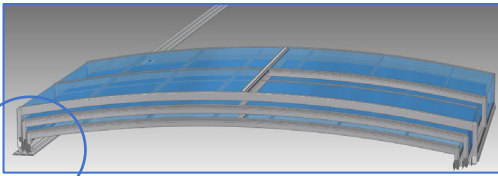

Markerade hål ska borraras med 4,1mm borrar enl. mall. Säkerställ att hål borraras genom två väggar då skruven ska gå igenom båda väggarna.
OBS! mallarnas position enligt bild 5.00
Mallen kan tas bort efteråt.

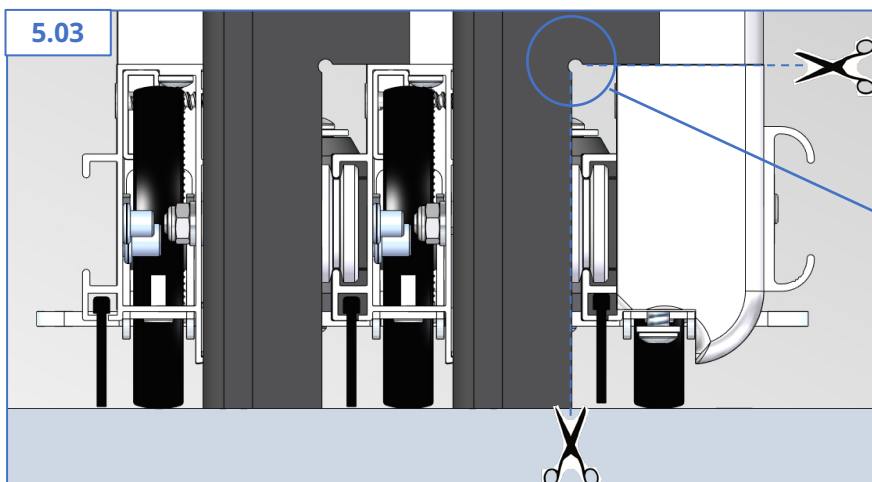
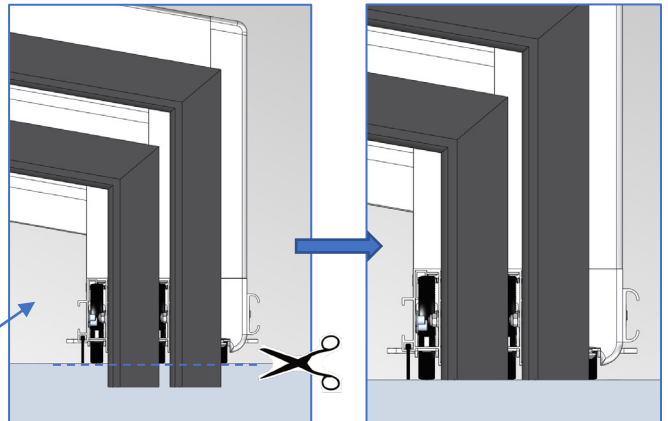
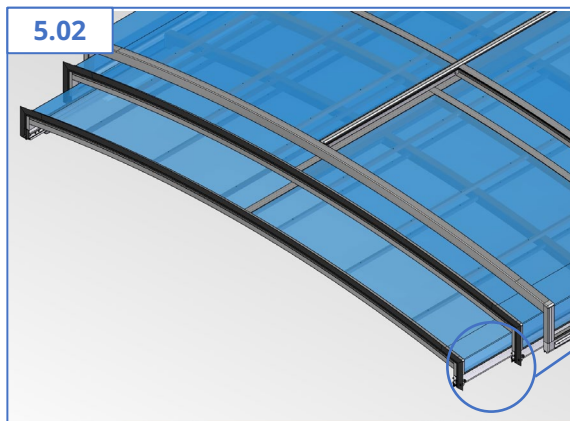
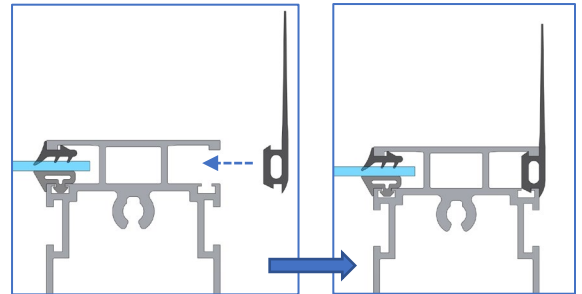
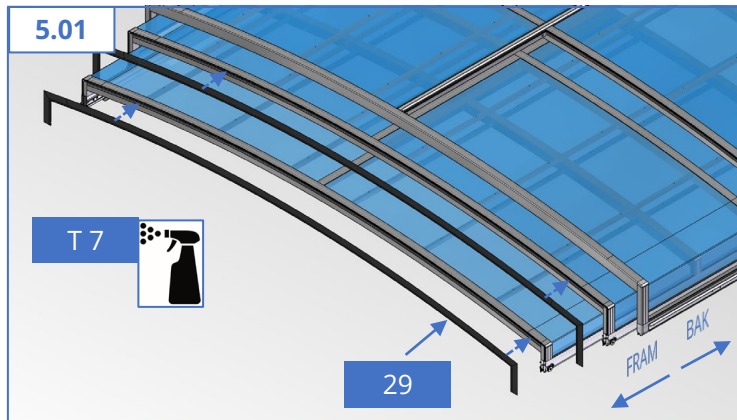
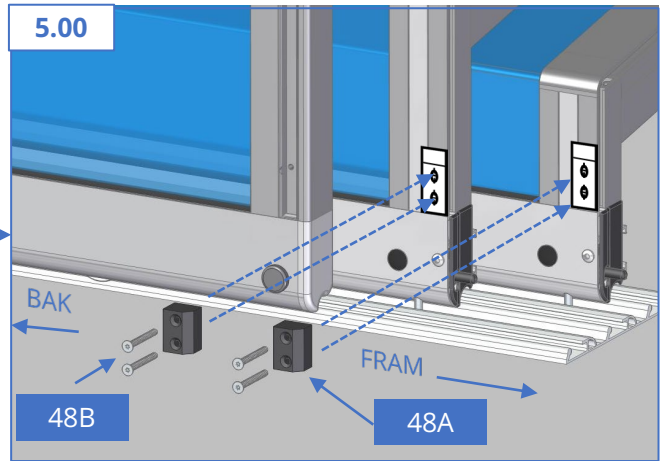

Gör en liten rundning i hörnan för att minska gummits slitage.

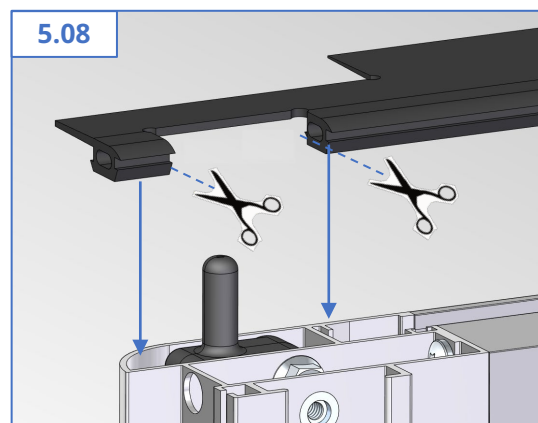
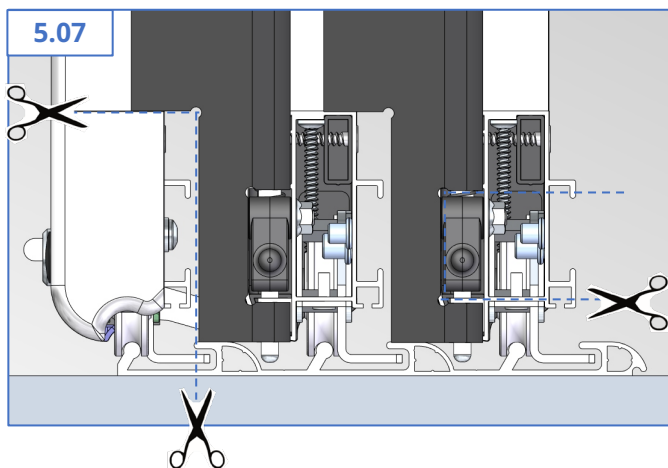
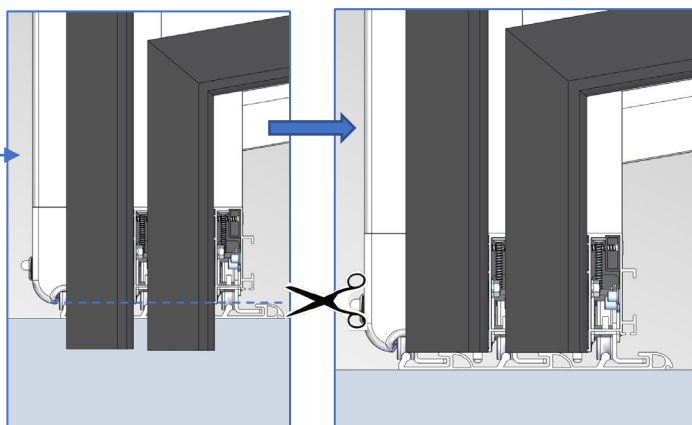
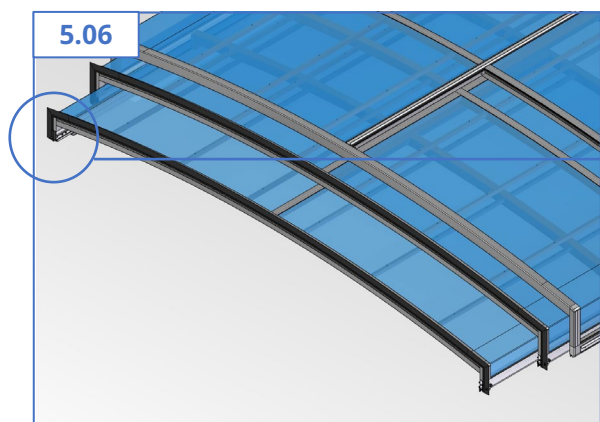
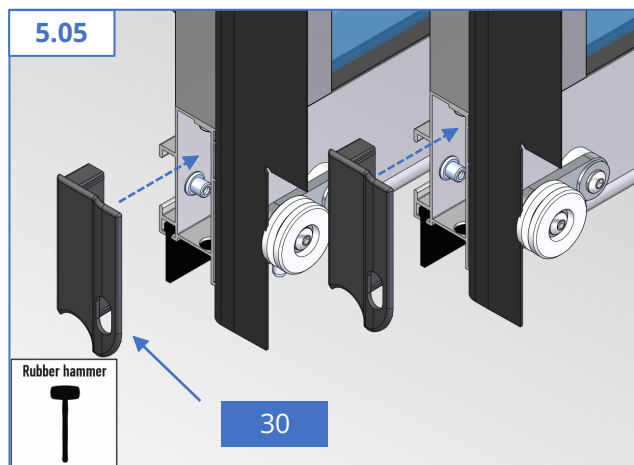
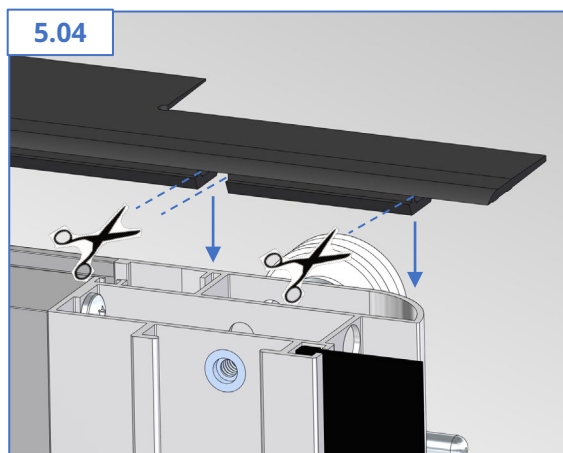

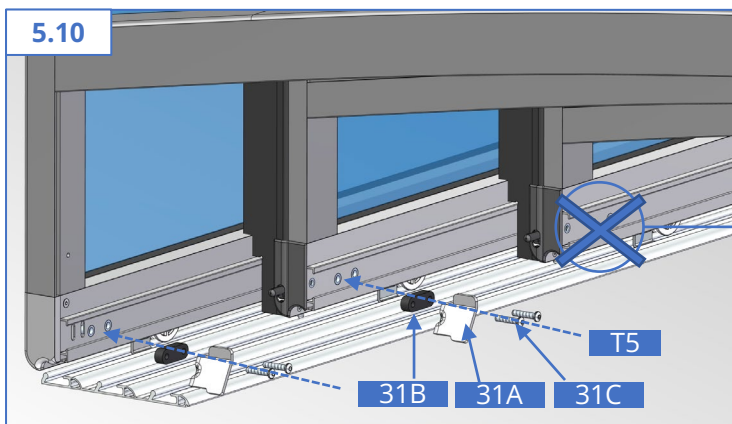
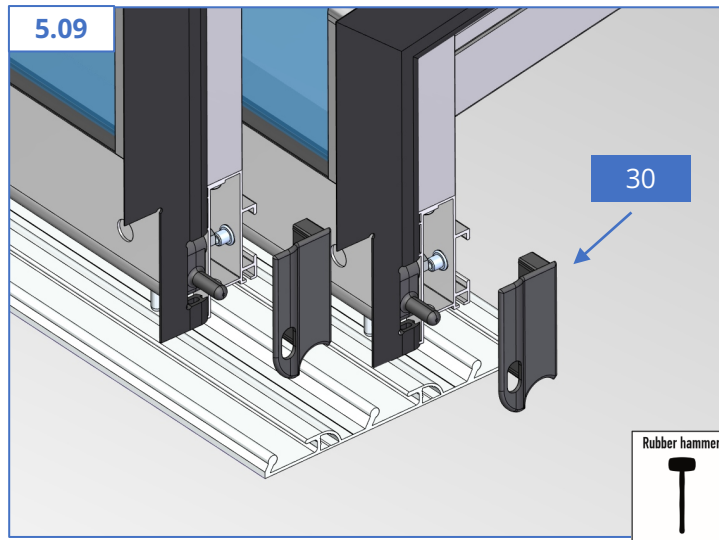

Låsbeslag (Nr.31.) ska inte monteras på minsta sektionen
TIPS!
Se gärna vår låsfil på
hemsidan som förklarar
funktionen.

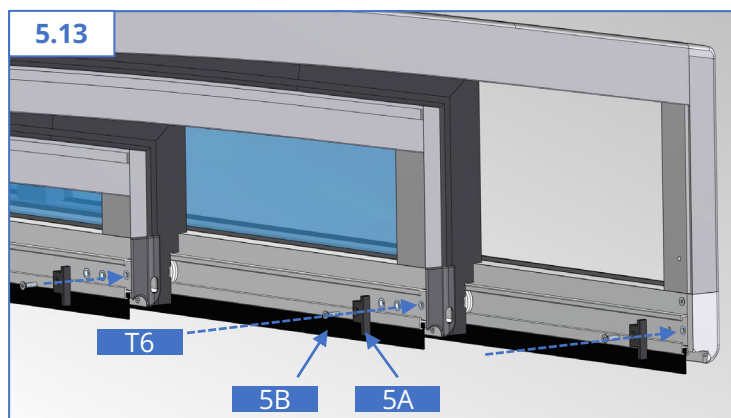
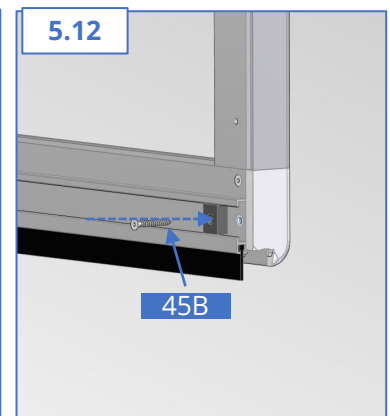
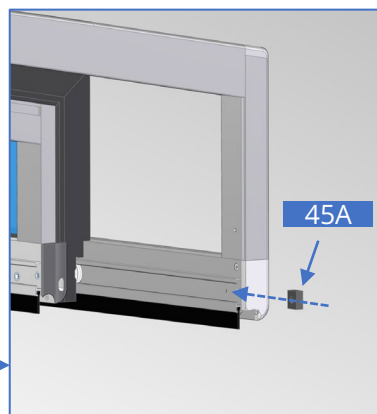
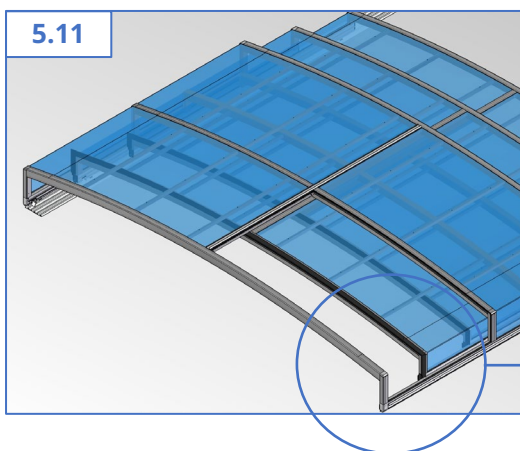

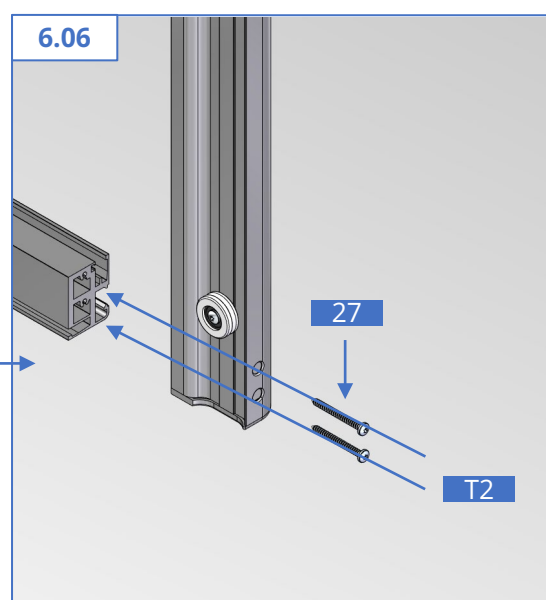
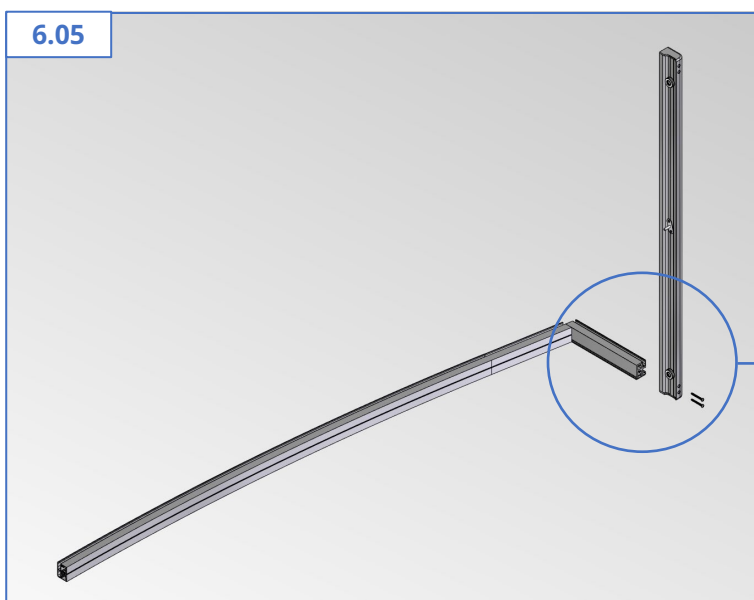
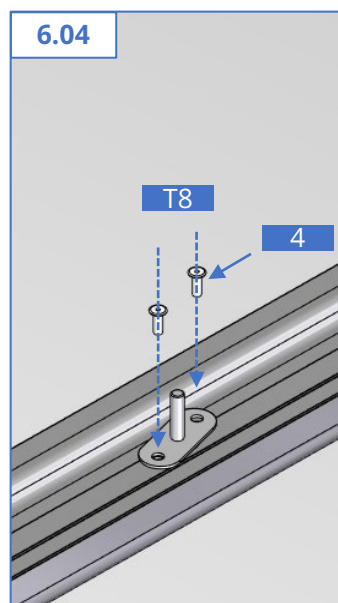
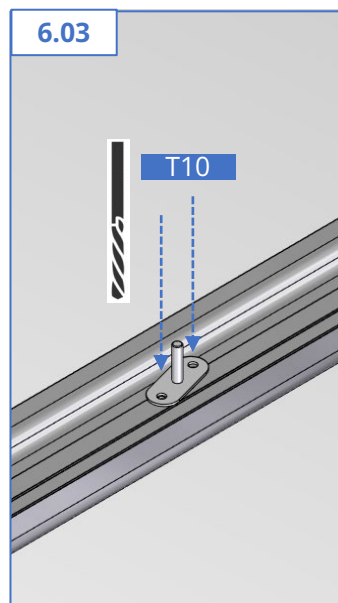
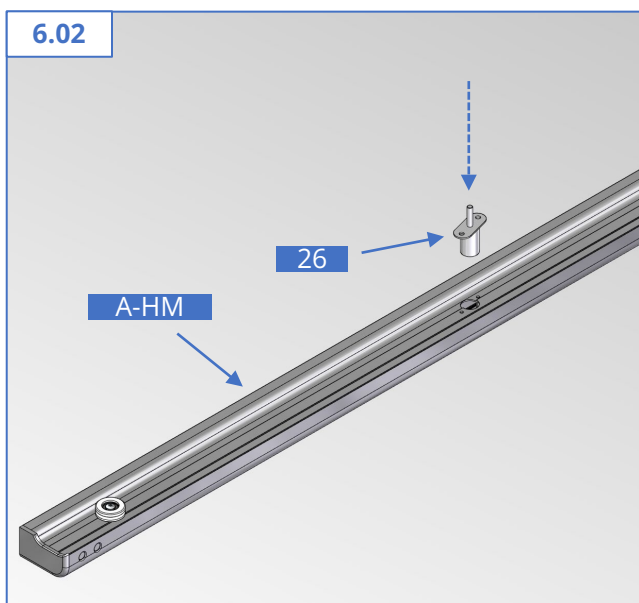
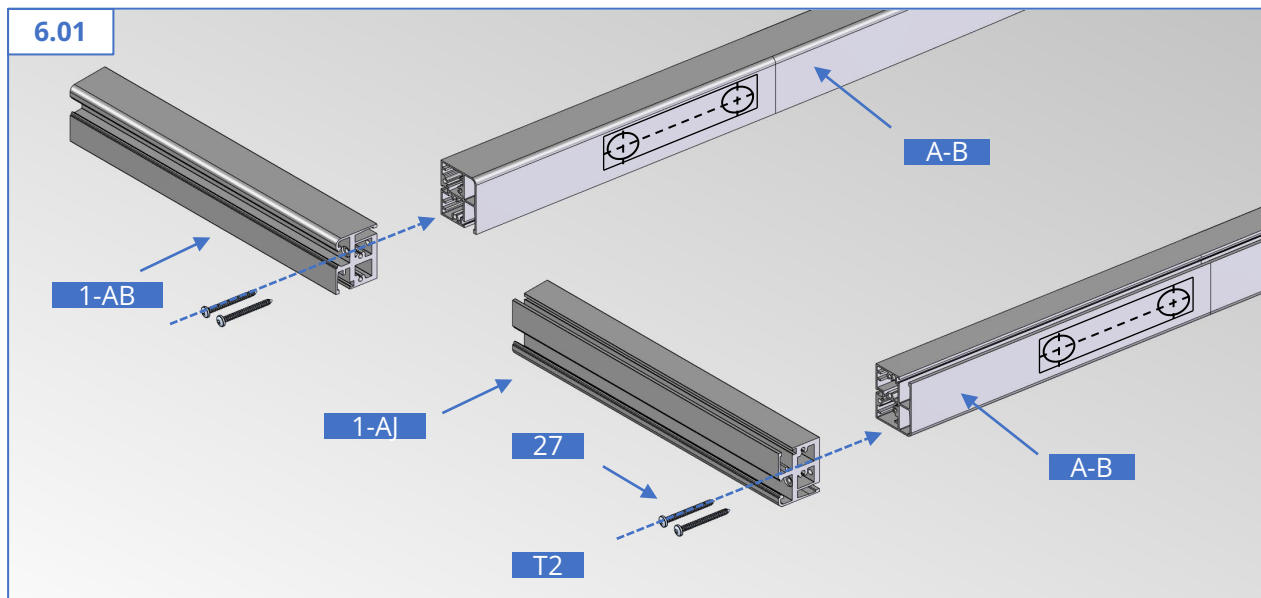

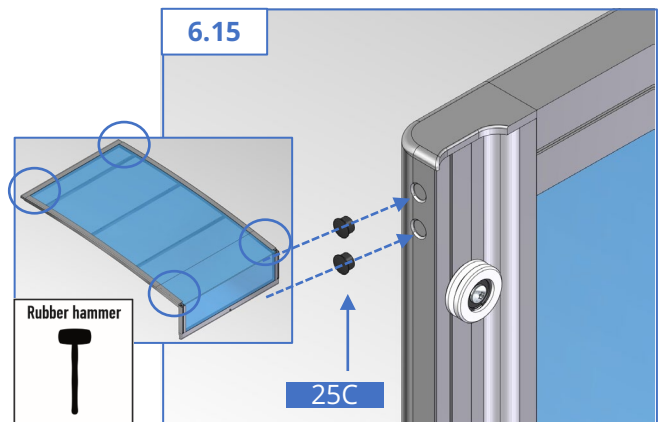
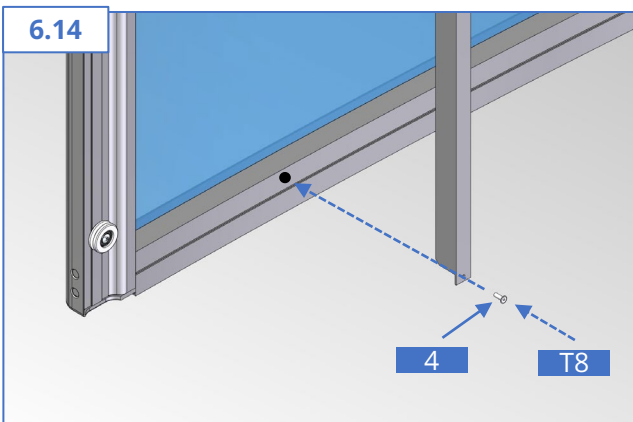
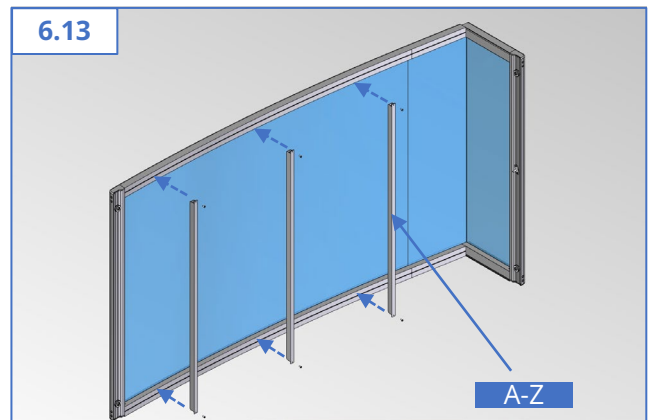
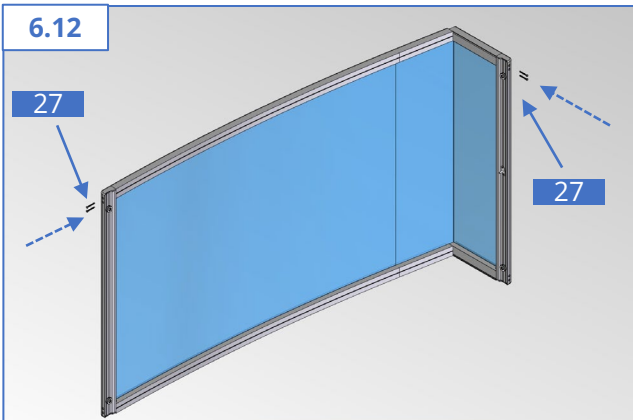
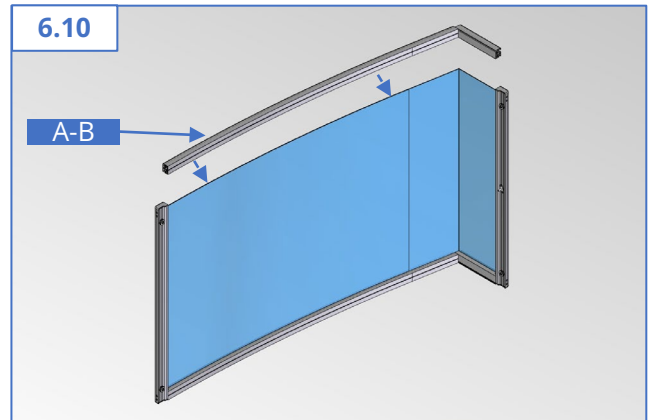
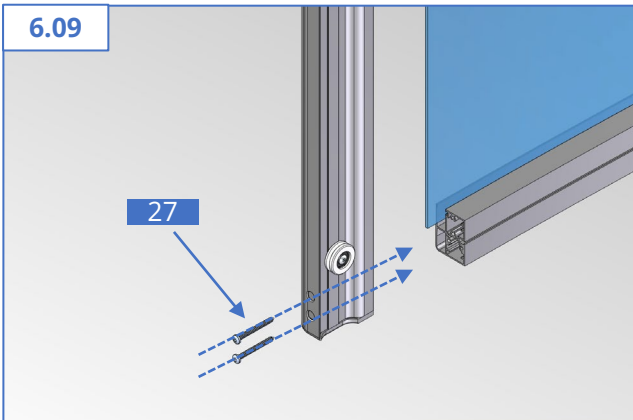
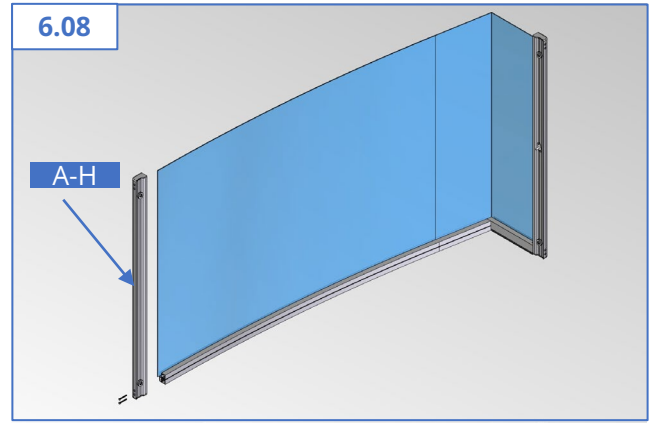
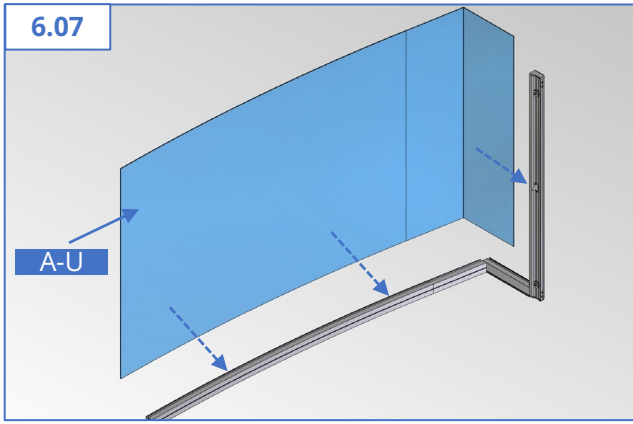

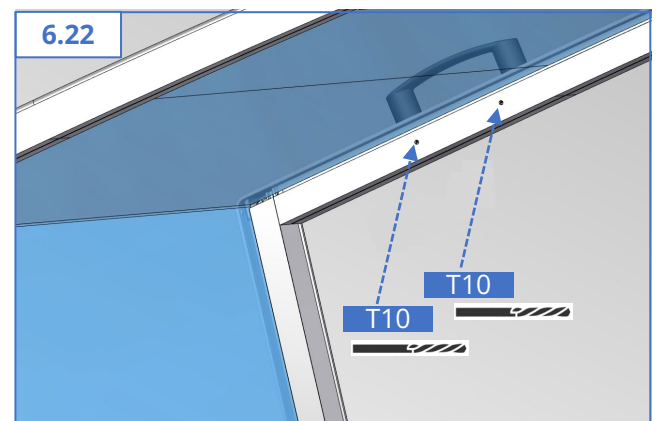
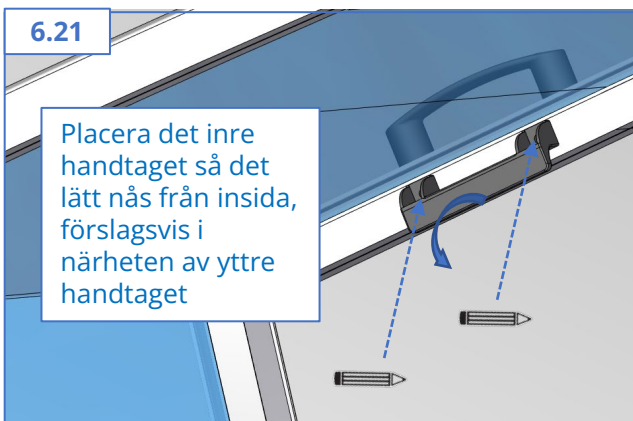
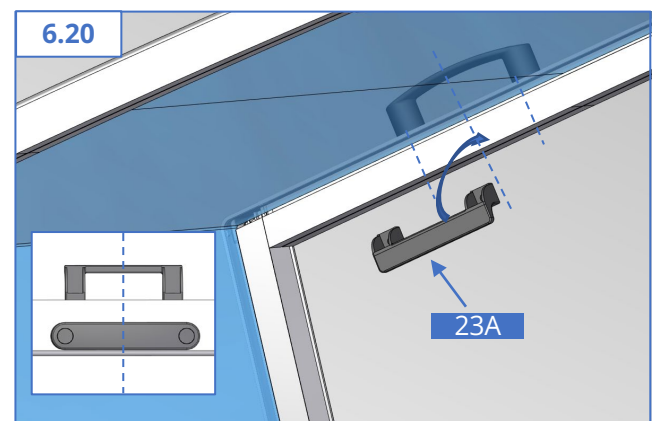
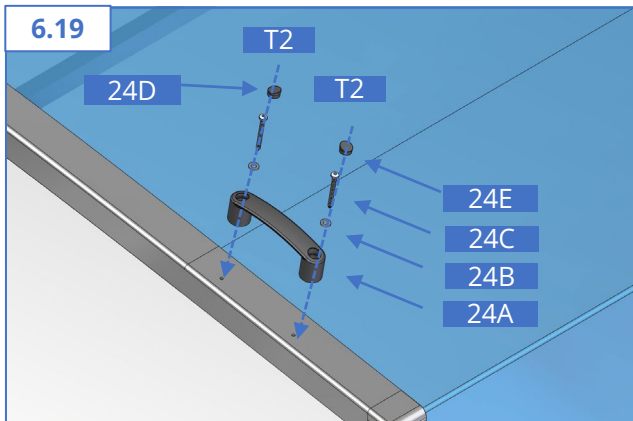
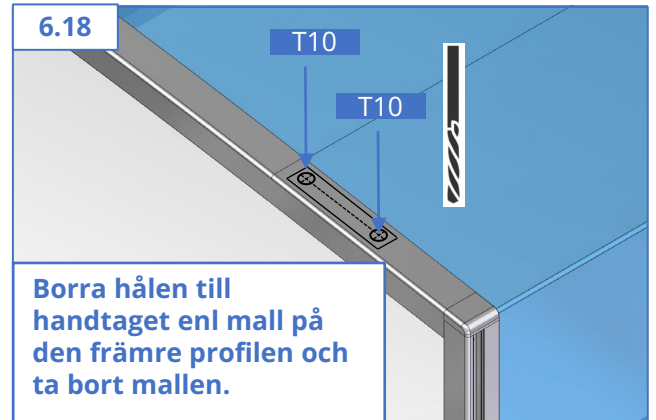
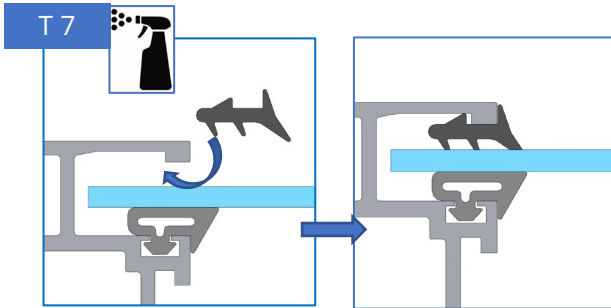
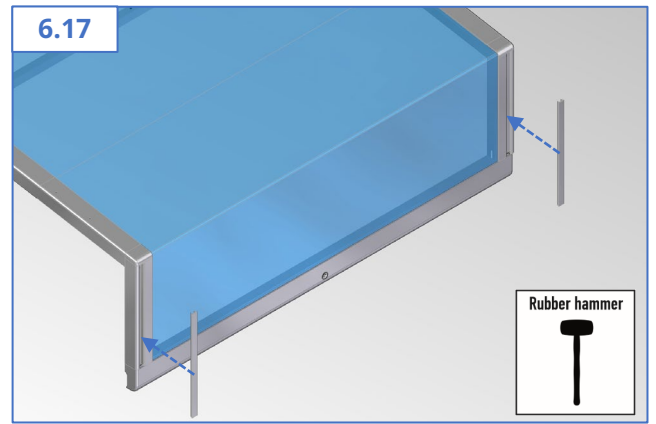
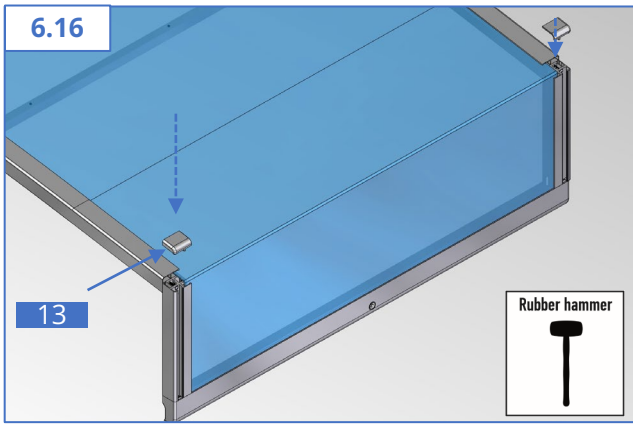



Vid montering av dörllisten (nr 28) börja i hörnan med hörnändstycken (nr 13-14) klipp listen ca 10 mm längre och montera listen. OBS! Sträck inte listen.

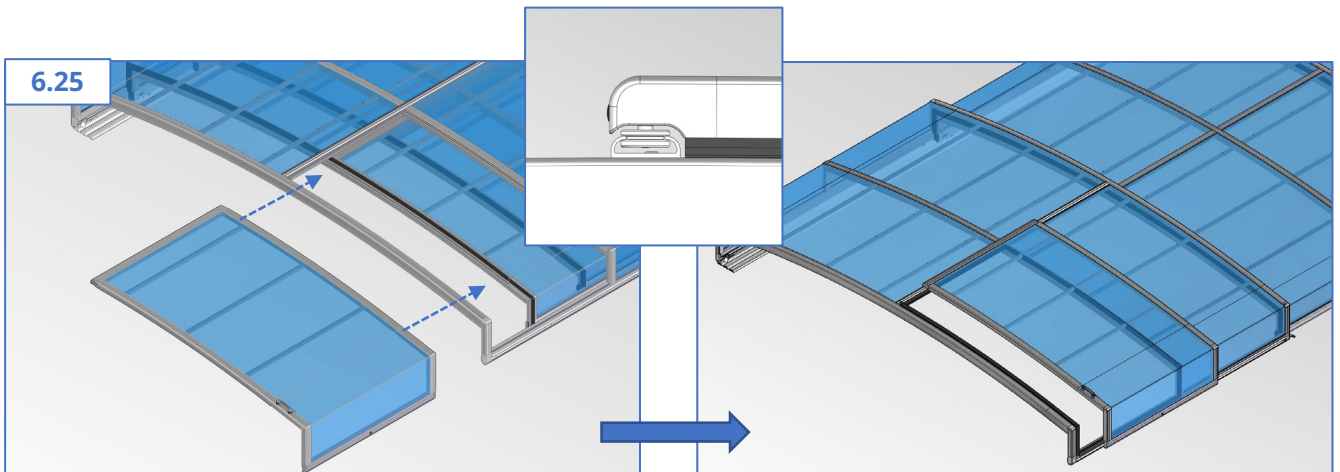
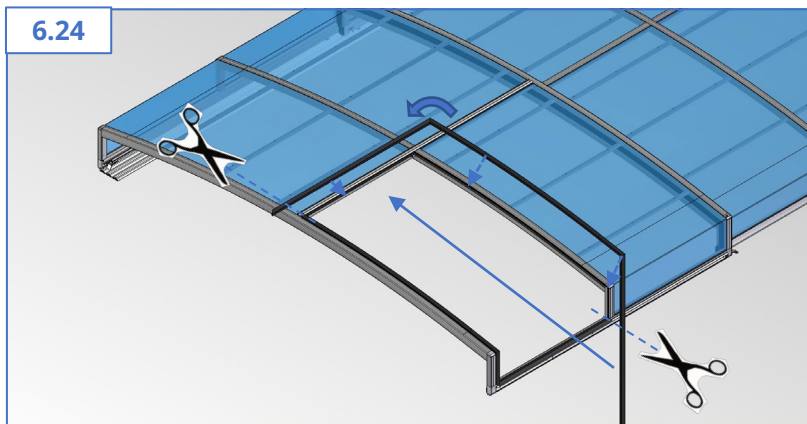
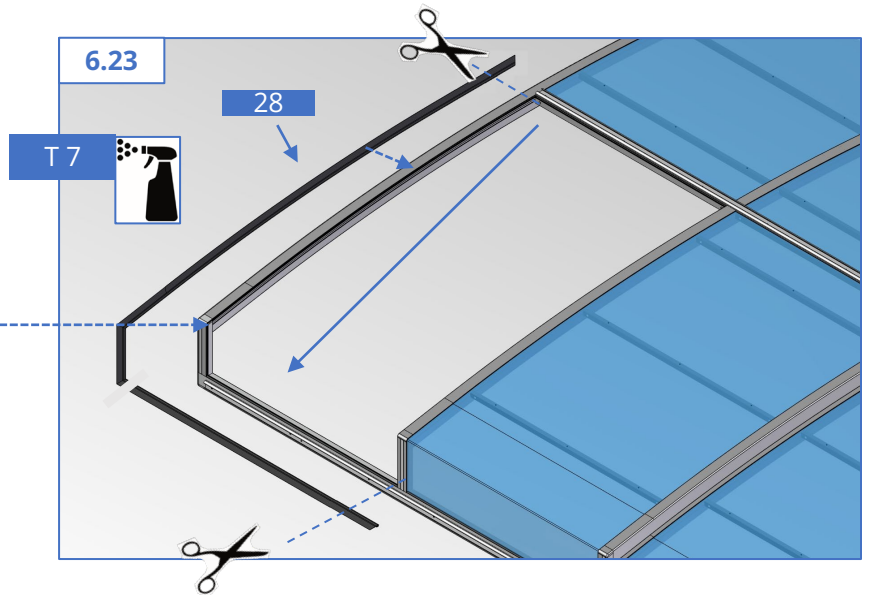
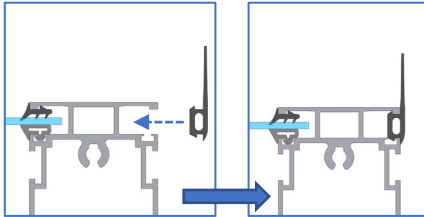

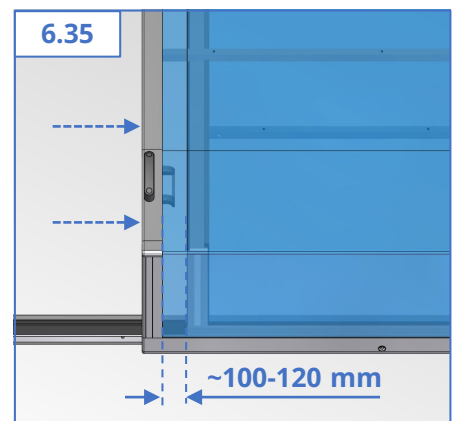
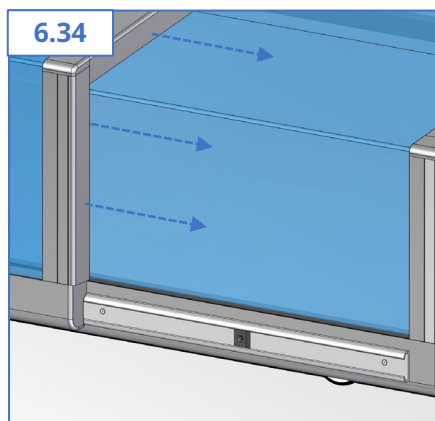
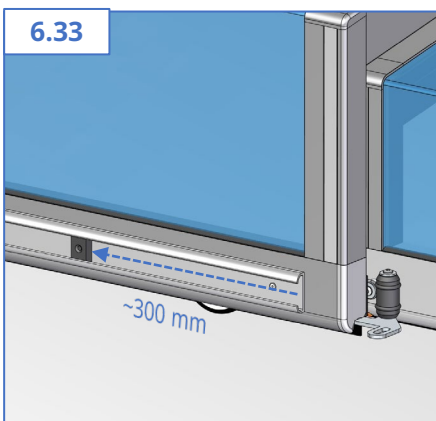
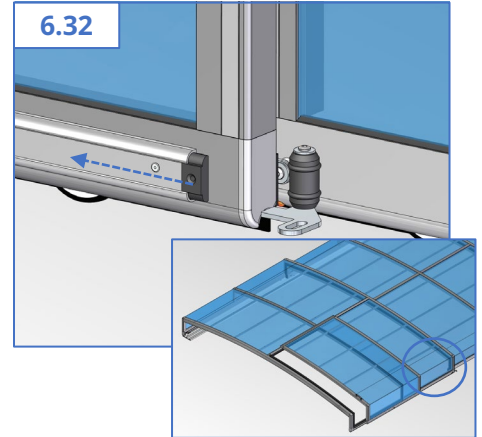
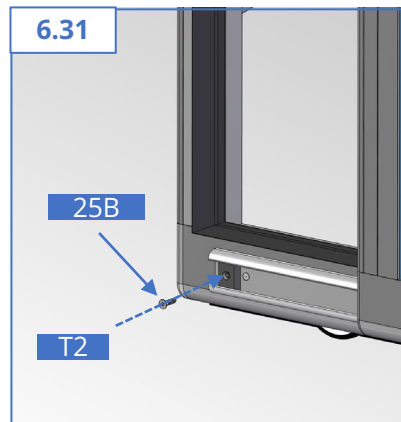
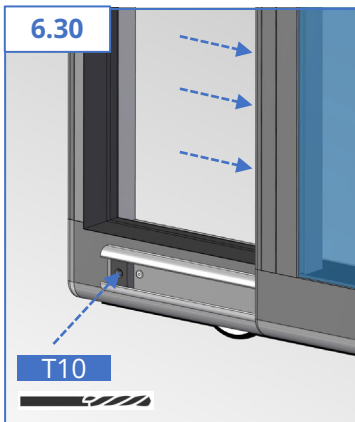
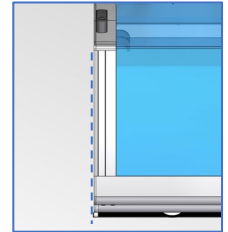
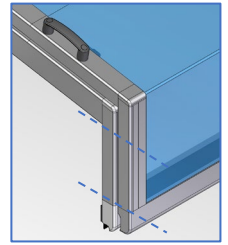
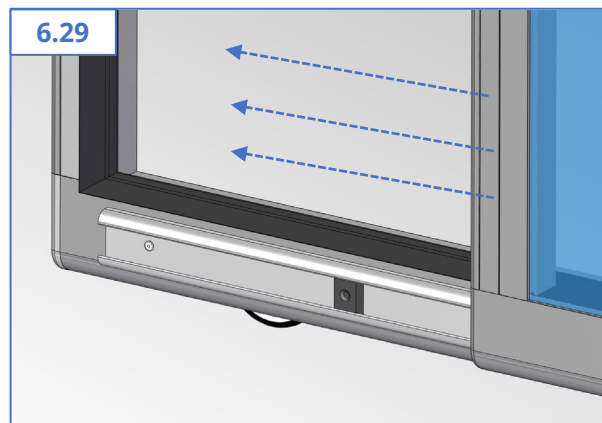
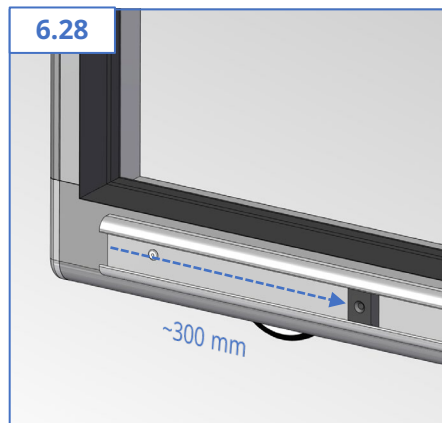
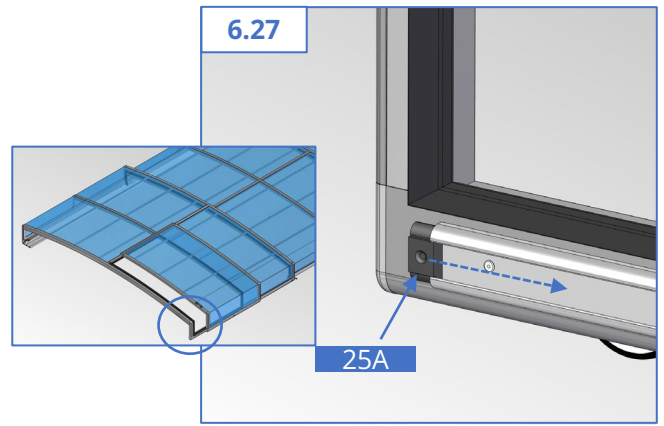
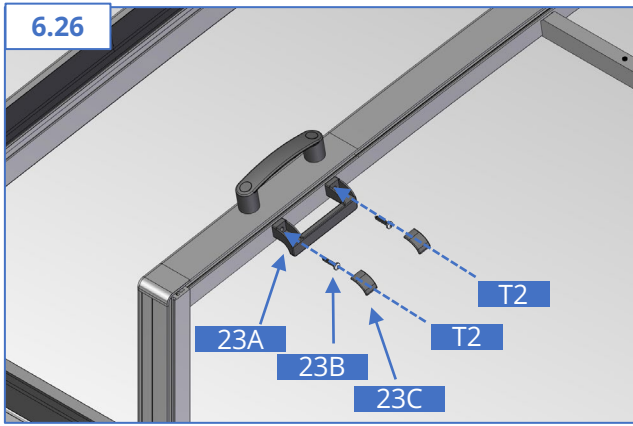

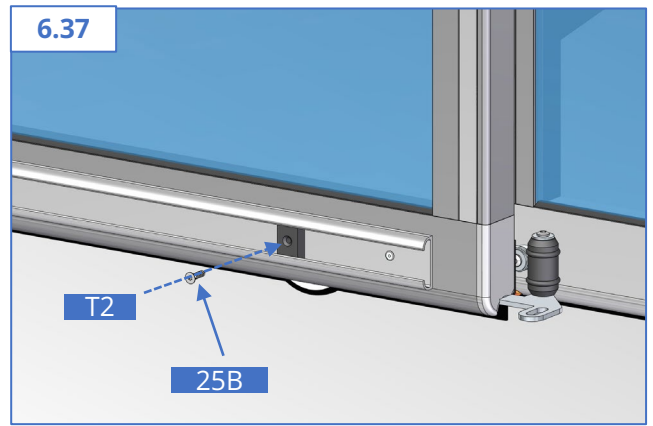
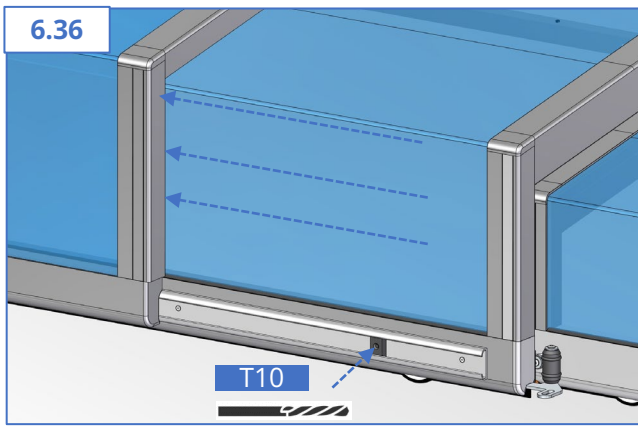

FRONTGAVEL:

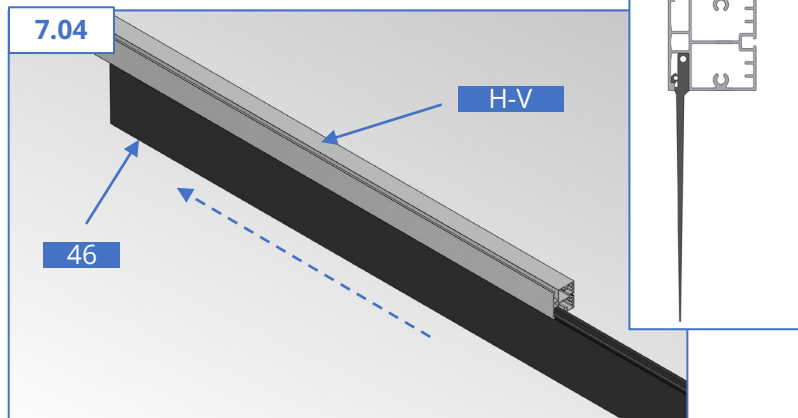
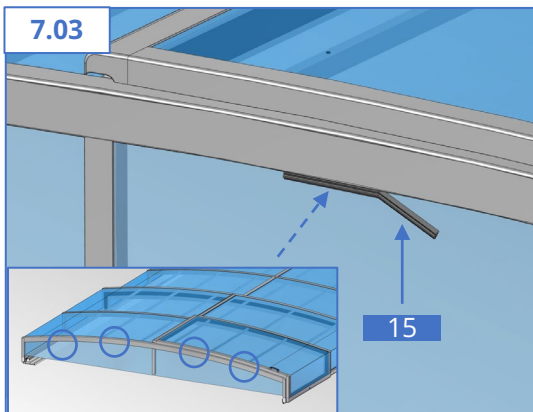
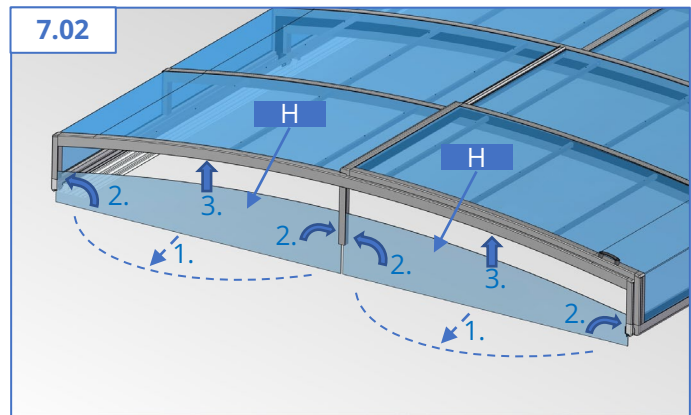
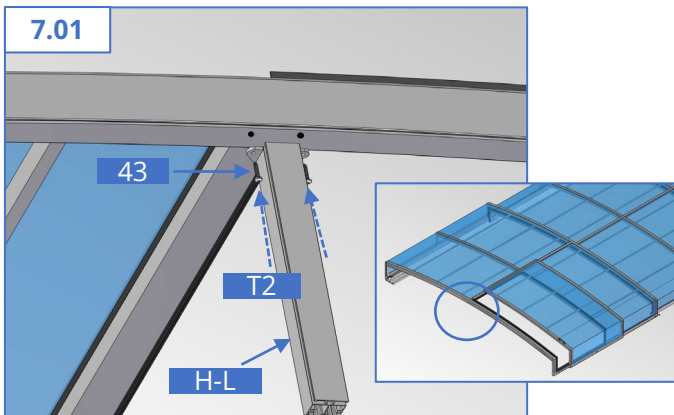

Fixera panelerna temporärt med en bit gummilist (ca 20cm) tills bottenprofilen är monterad

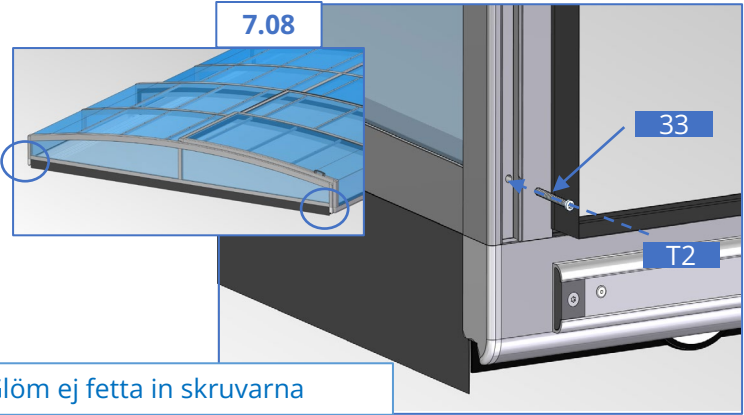
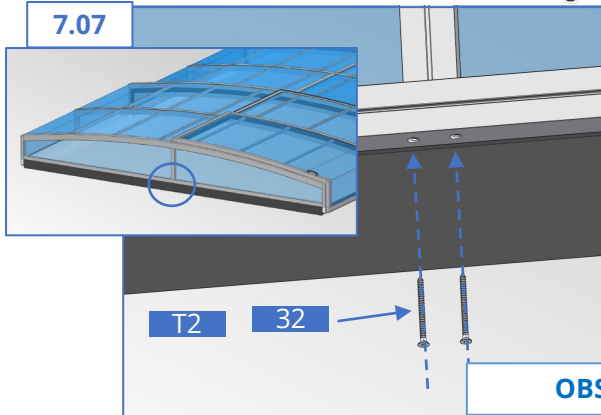
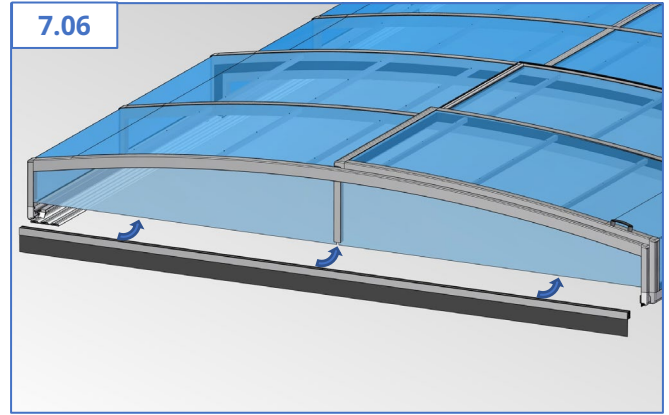
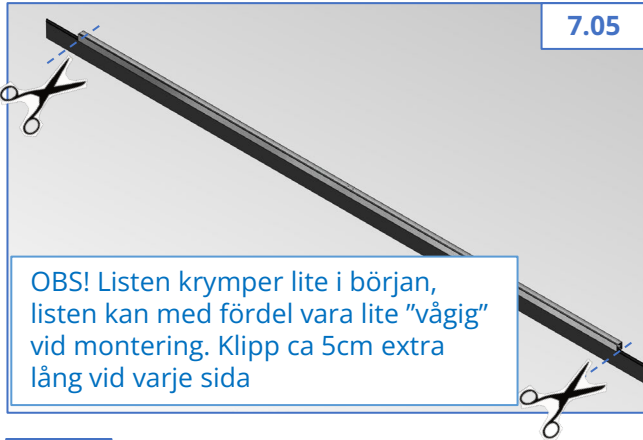

OBS! Glöm ej fetta in skruvarna

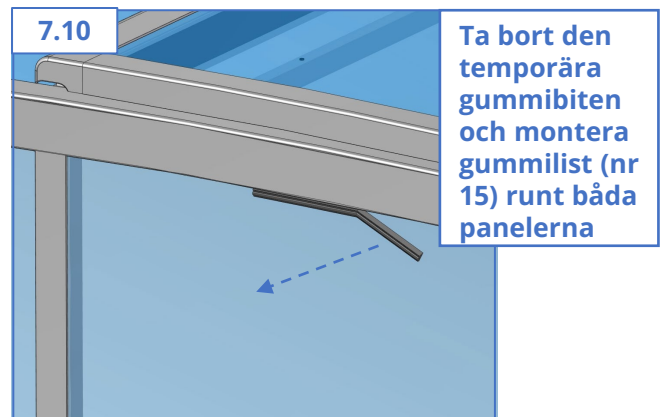
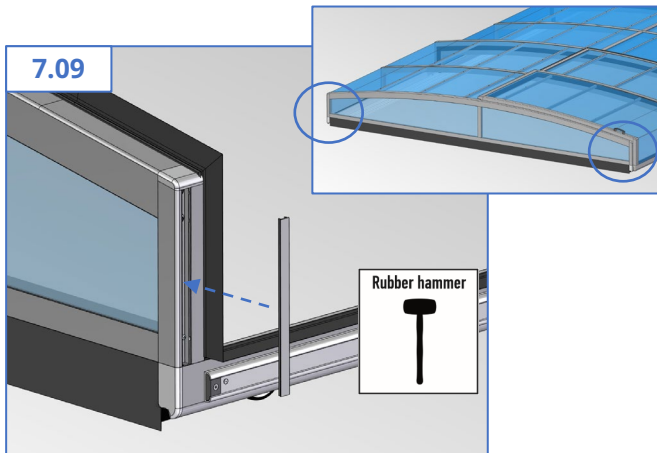

BAKGAVEL:

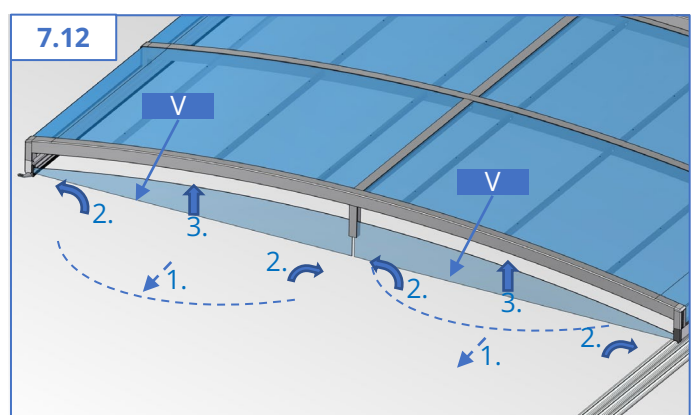
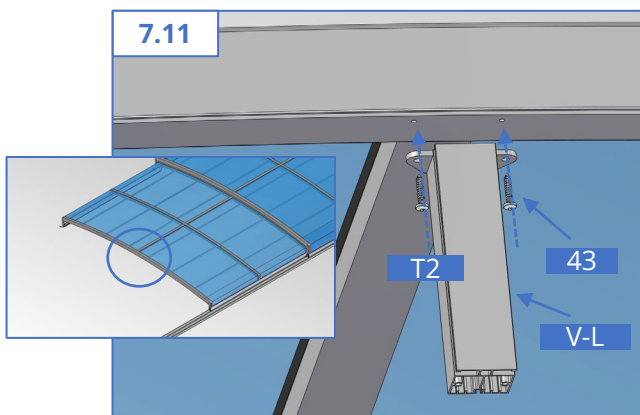

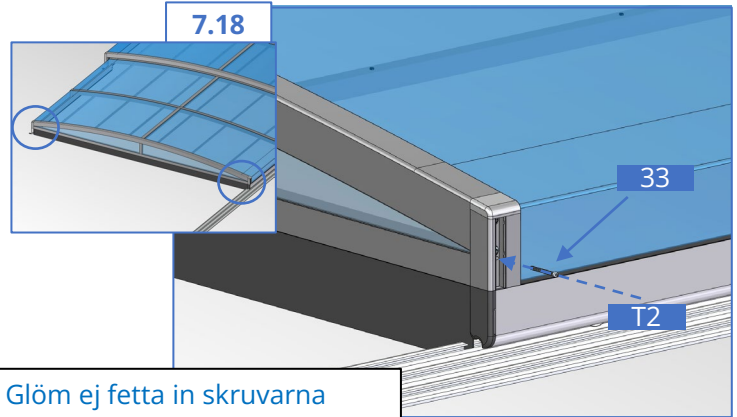
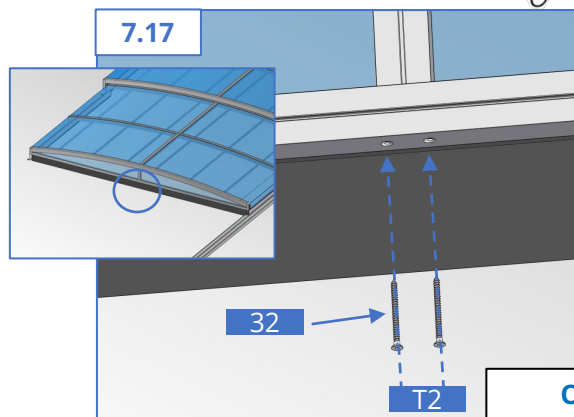
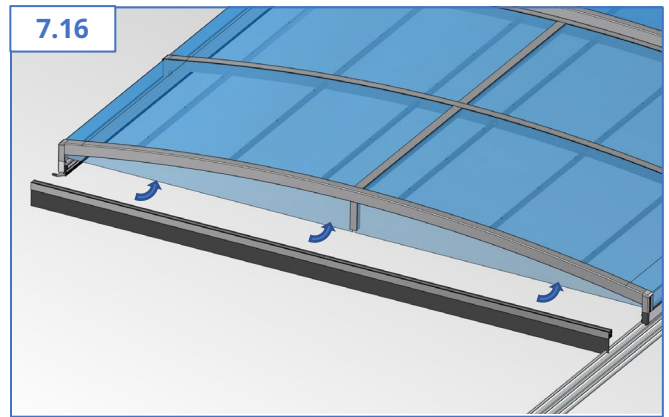
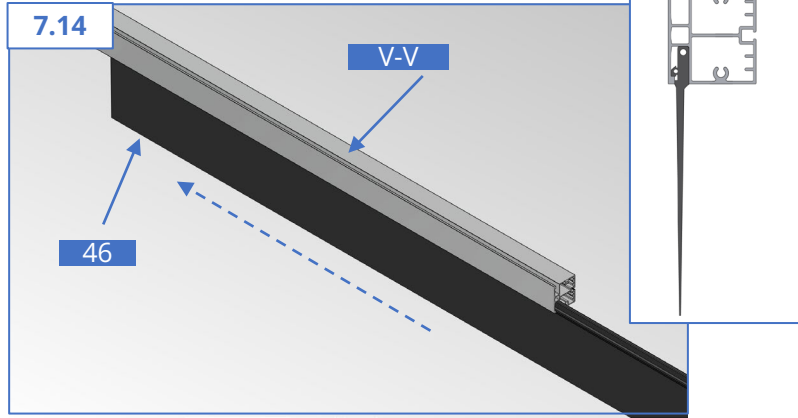
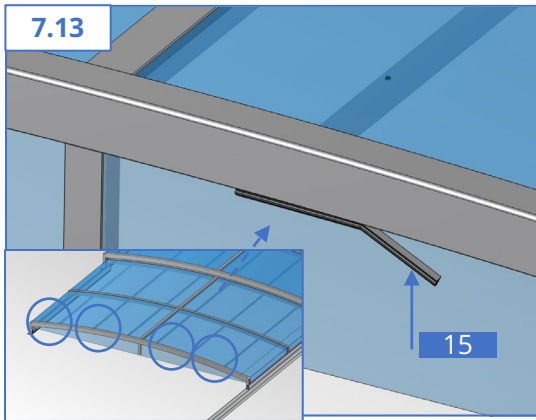

OBS! Glöm ej fetta in skruvarna

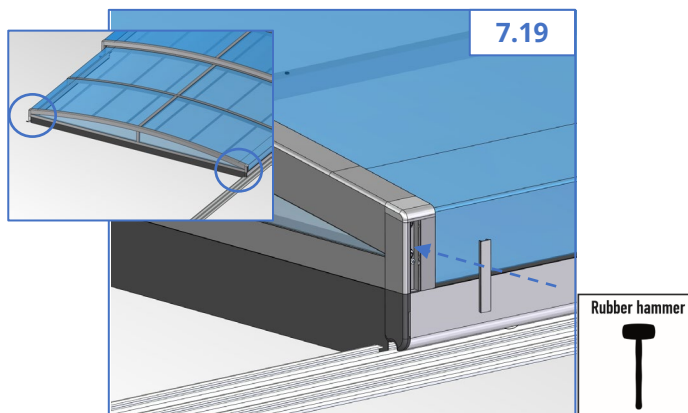

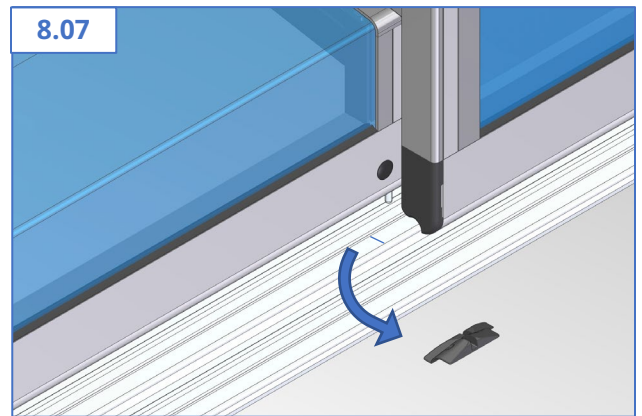
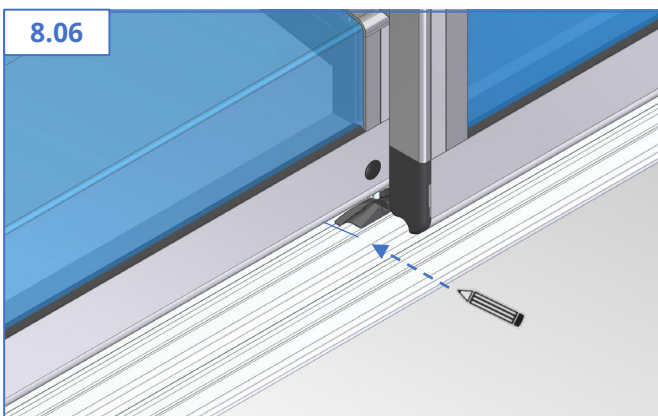
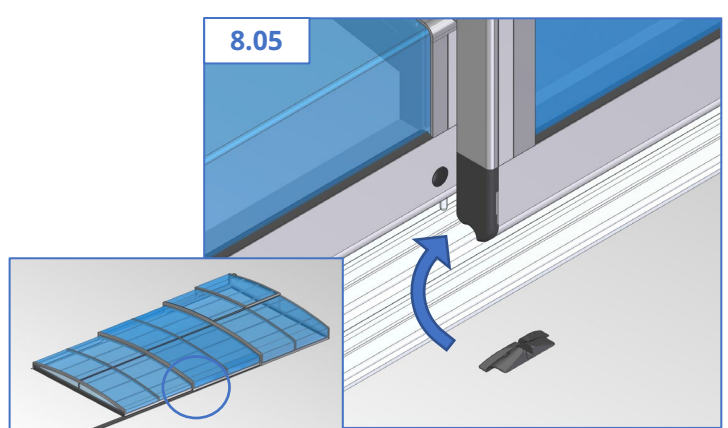
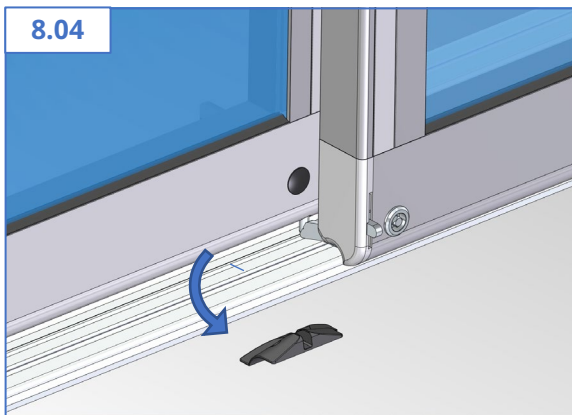
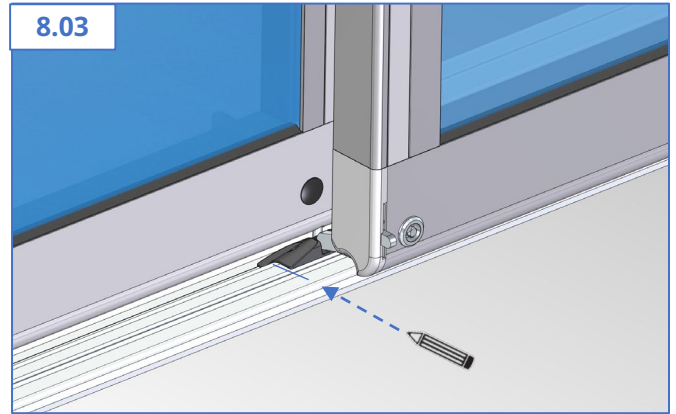
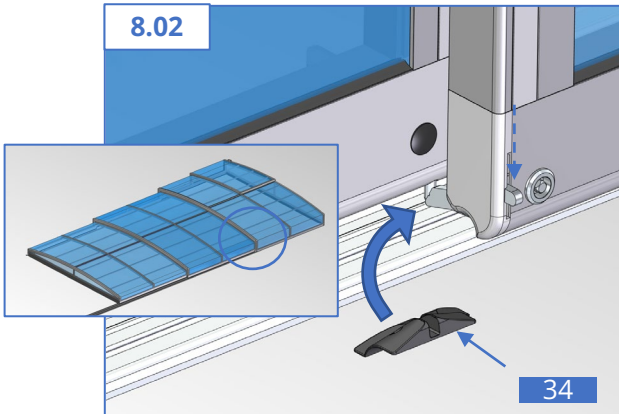
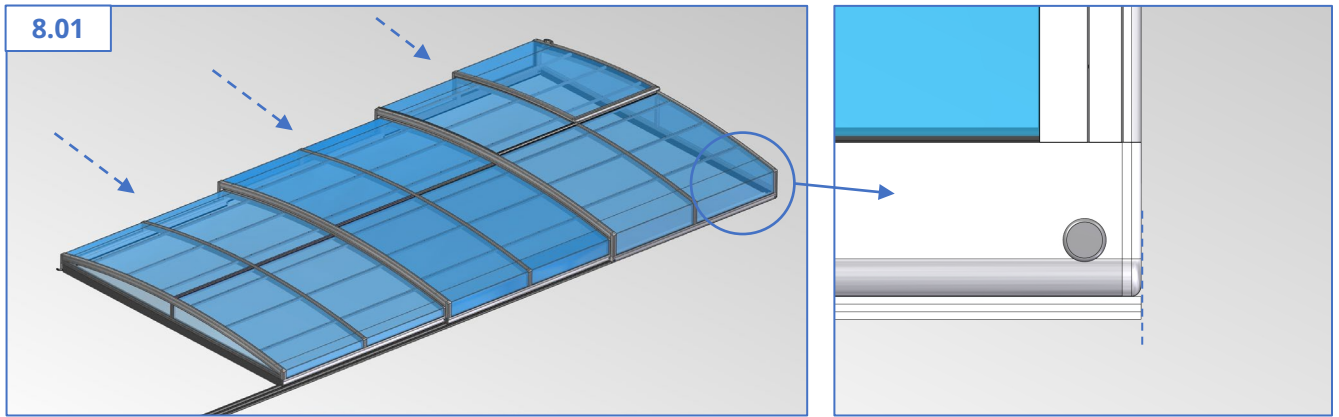

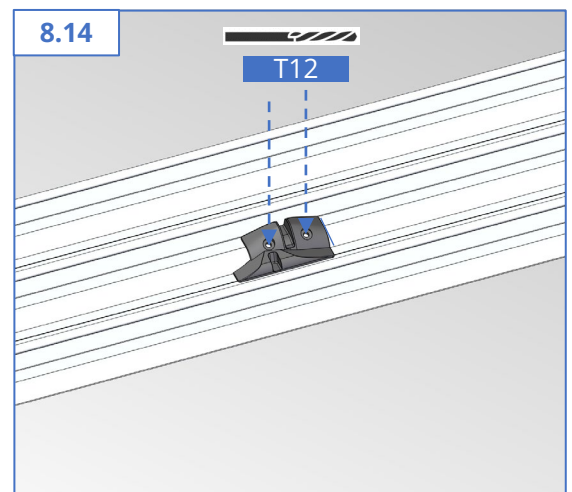
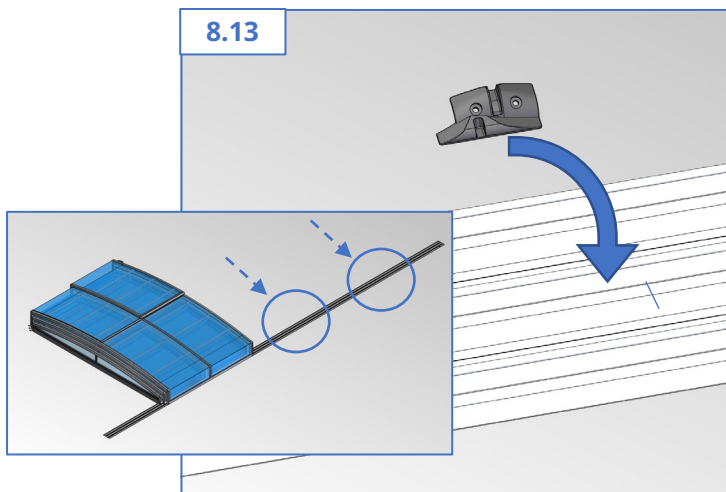
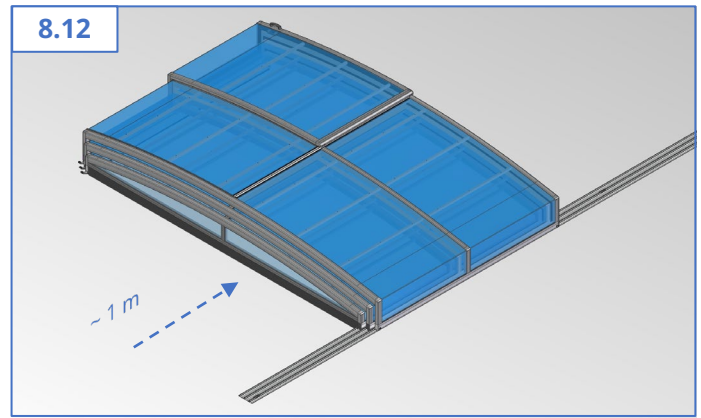
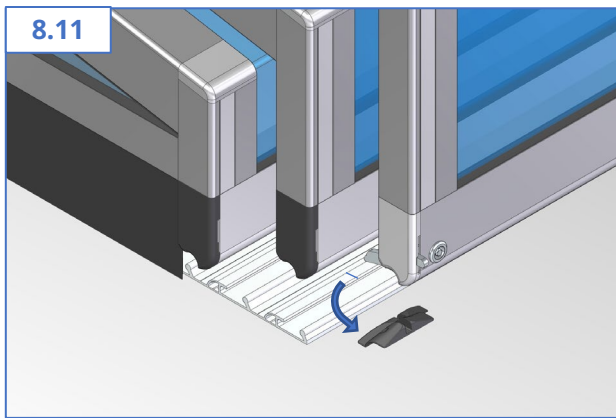
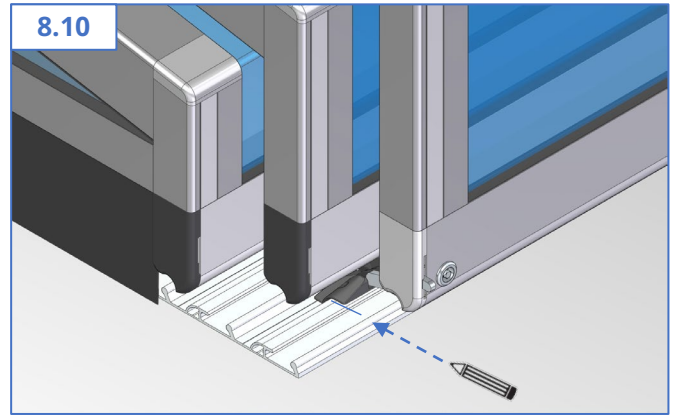
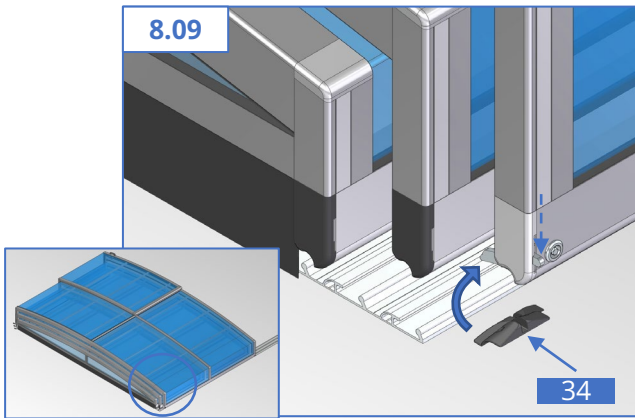
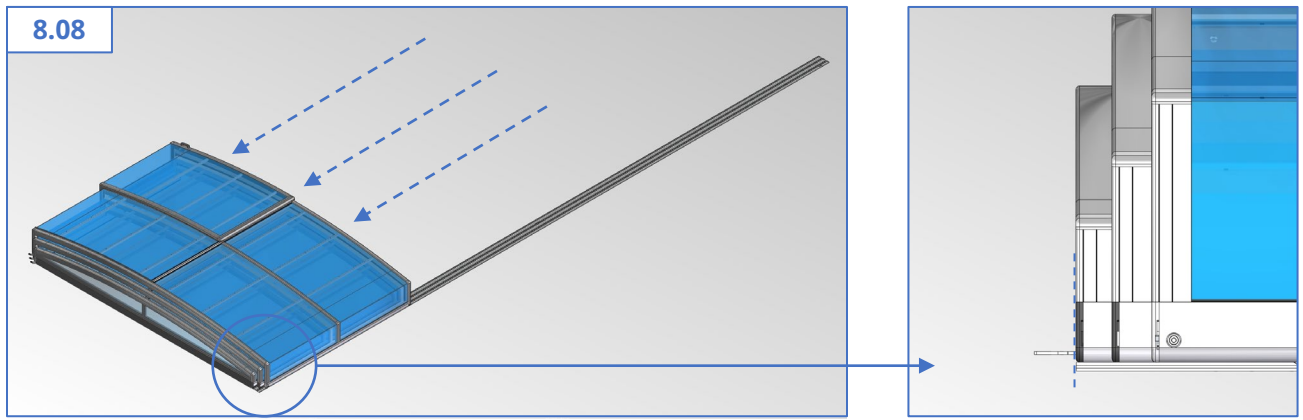



8.15

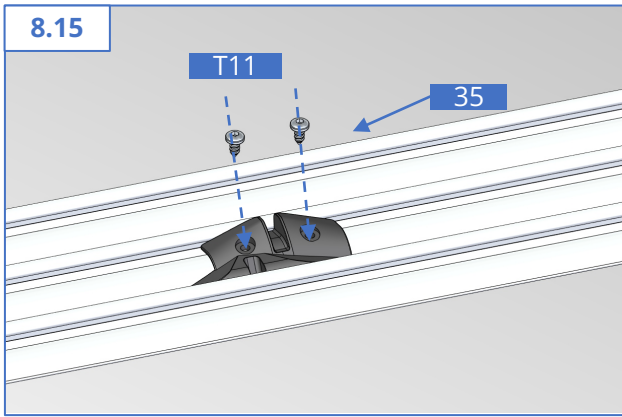

8.16

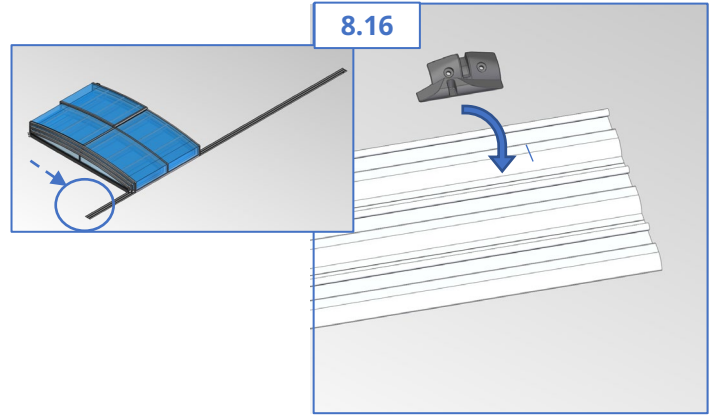

8.17

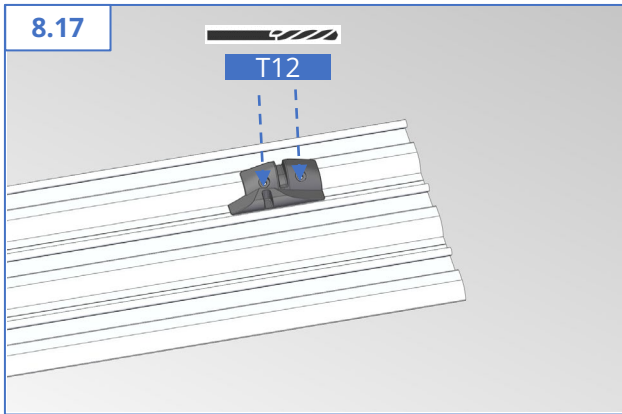

8.18

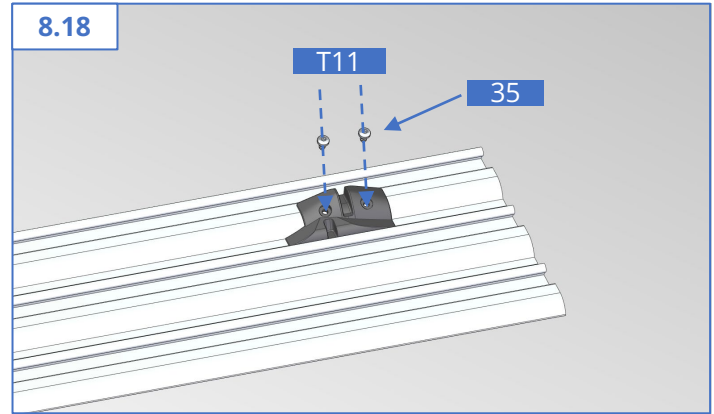

8.19

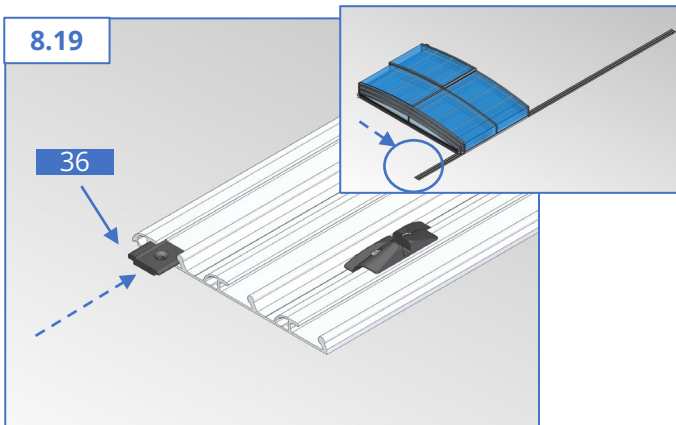

8.20

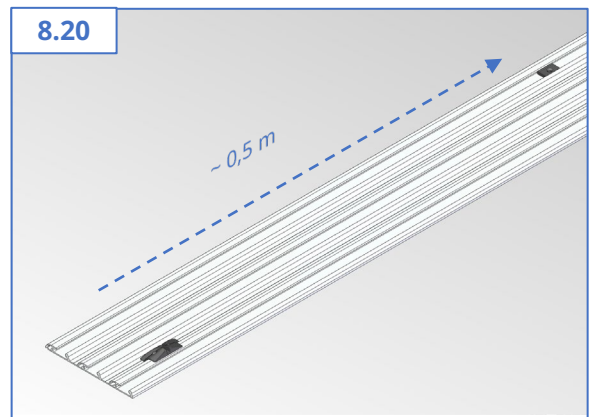

8.21

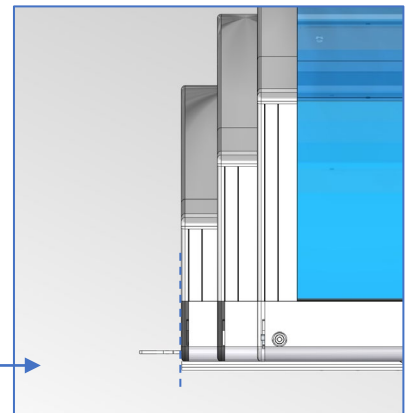
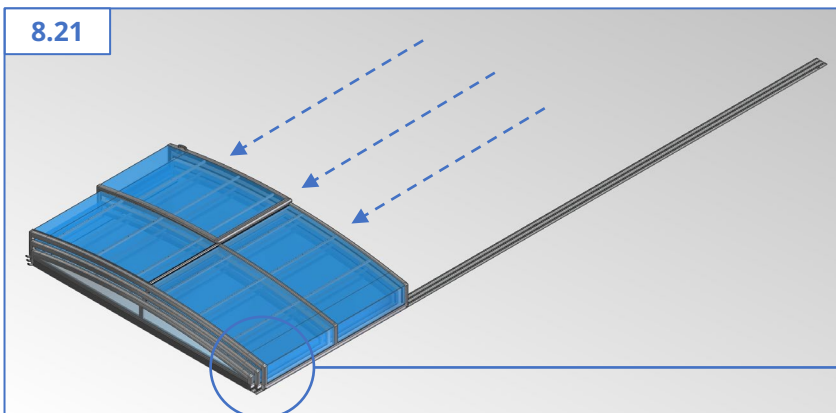

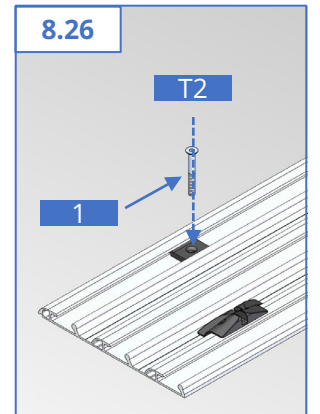
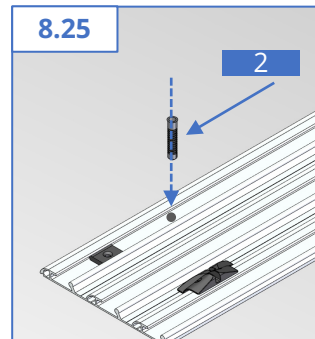
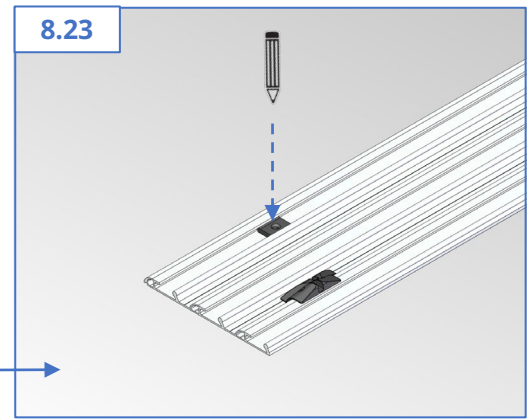
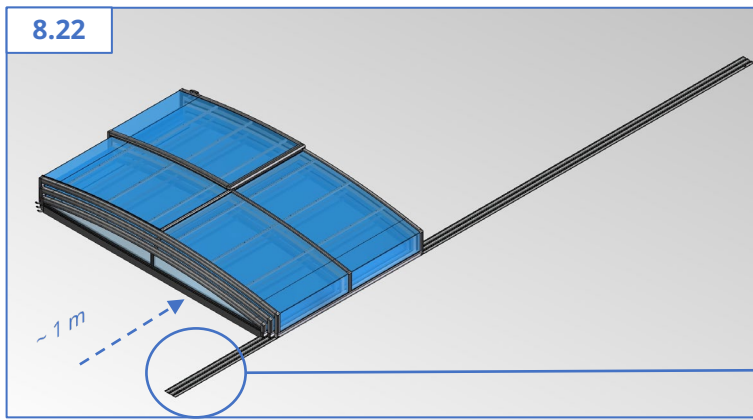

På hårt underlag (ej trä) ska hålen borraras med 7 mm borrar och sen 10 mm borrar under skenan och minst ett djup på 60 mm

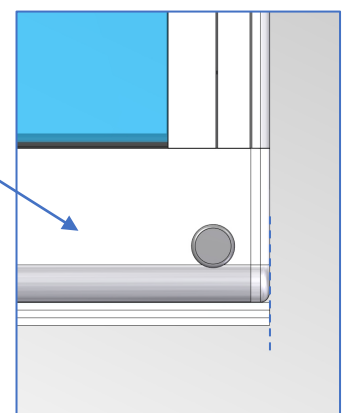
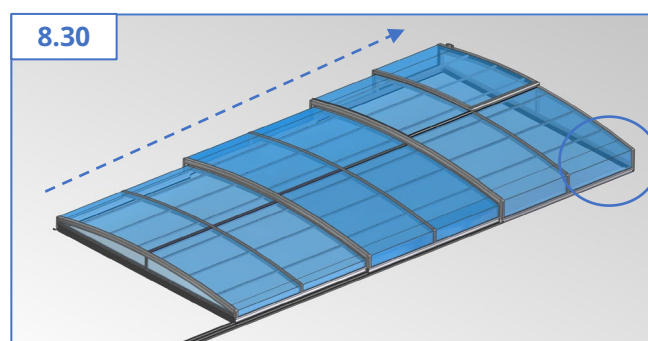
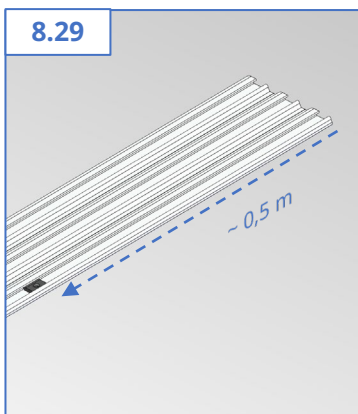
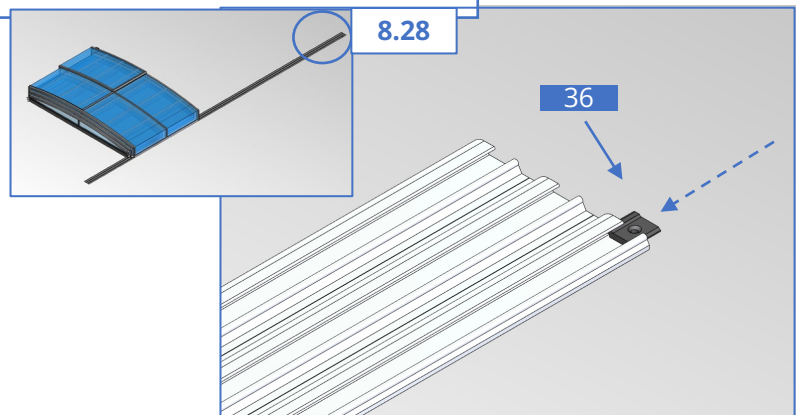
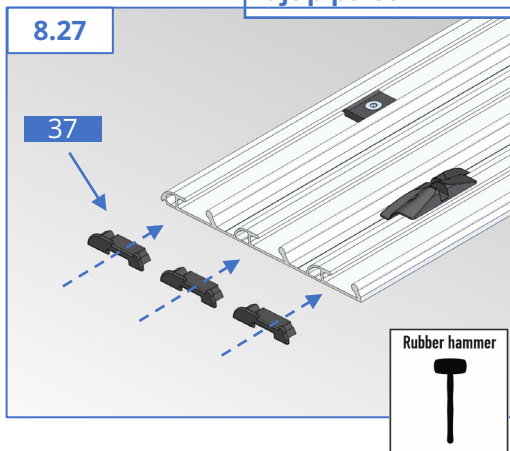

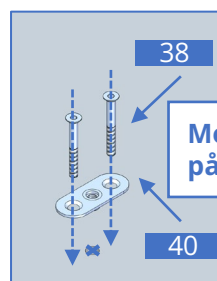
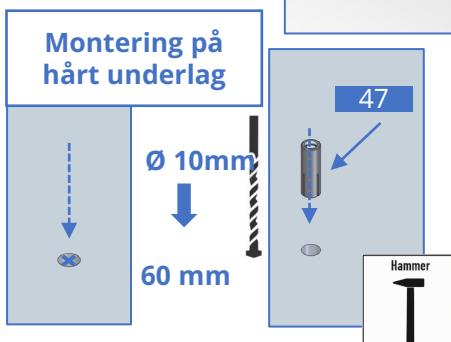
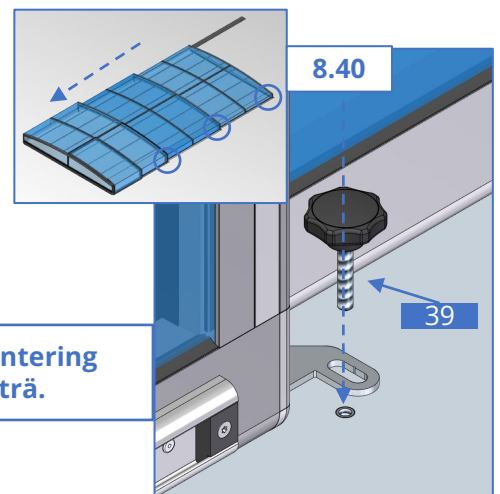
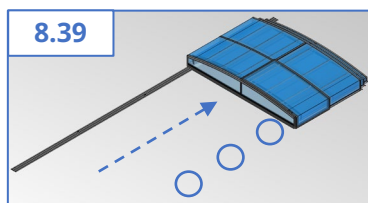
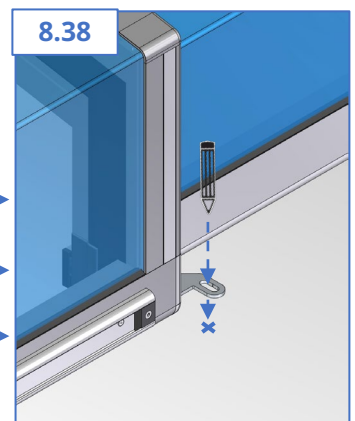
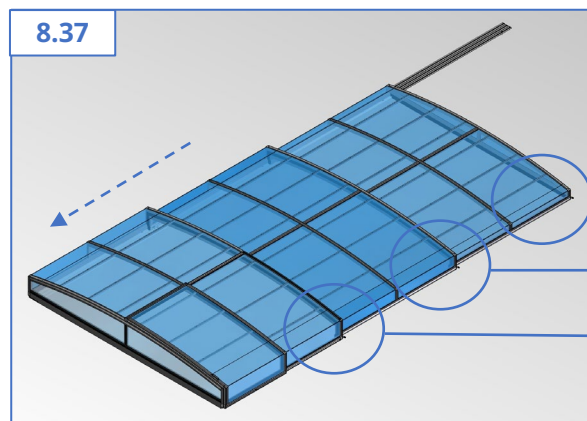
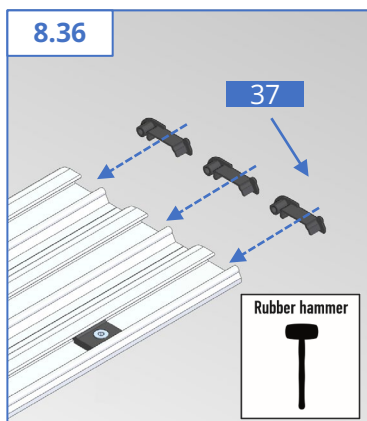
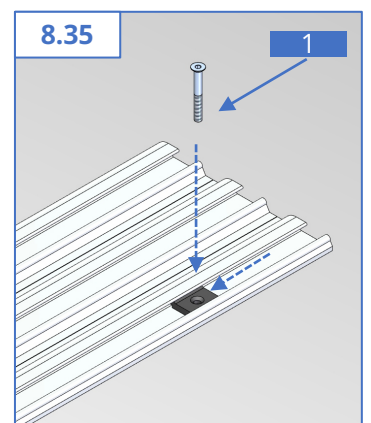
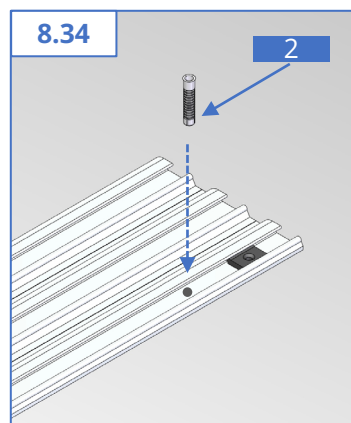
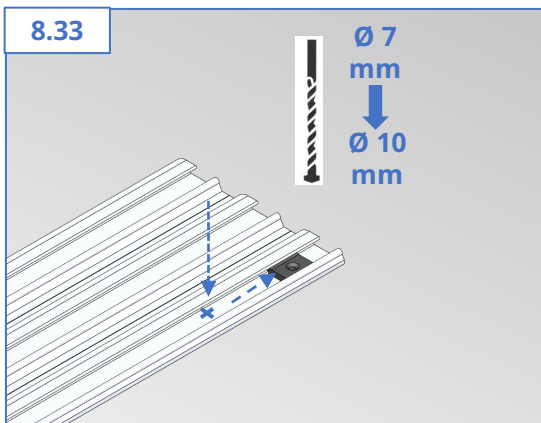
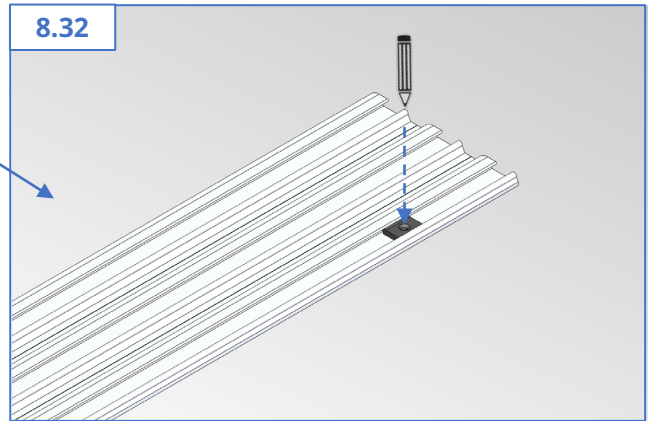
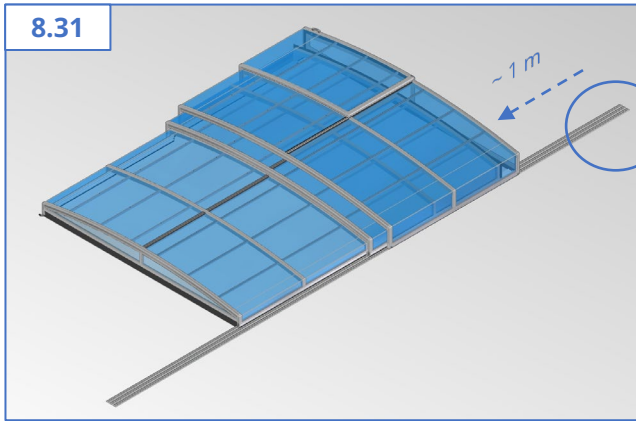

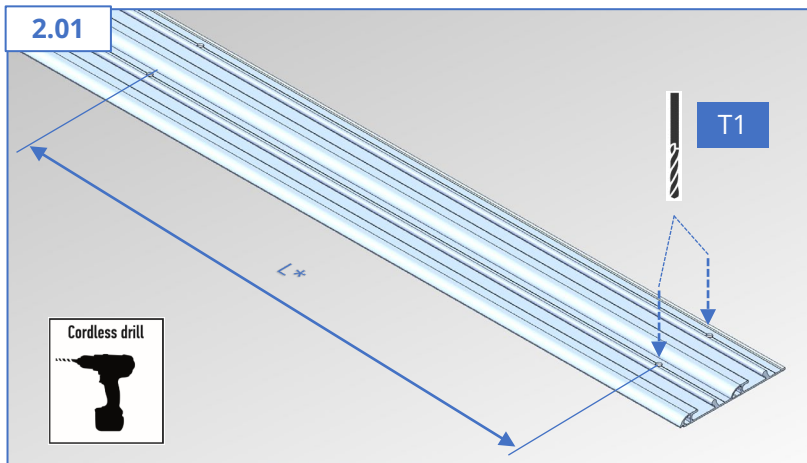

L* - Borrhålets position olika beroende på modell!
(Se sidan 3 i modellspecifik monteringsmanual)

OBS! Skruvarna ska försänkas

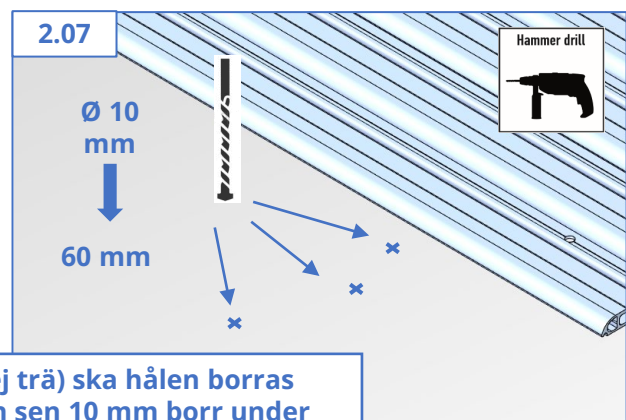
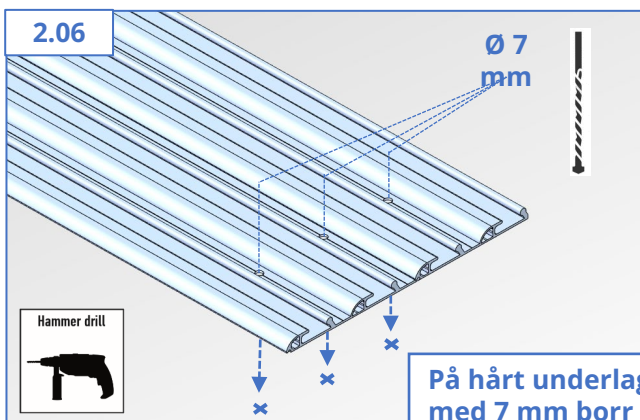
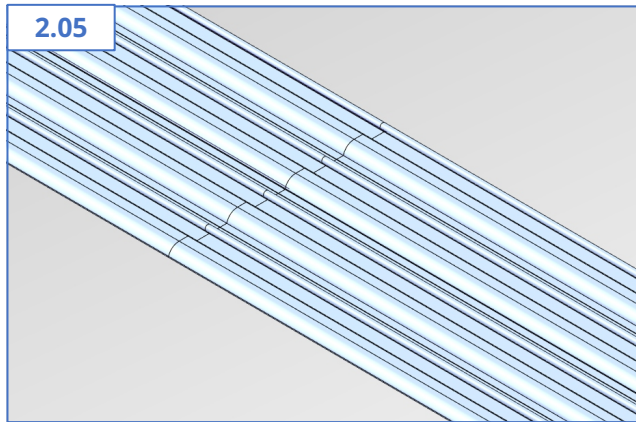
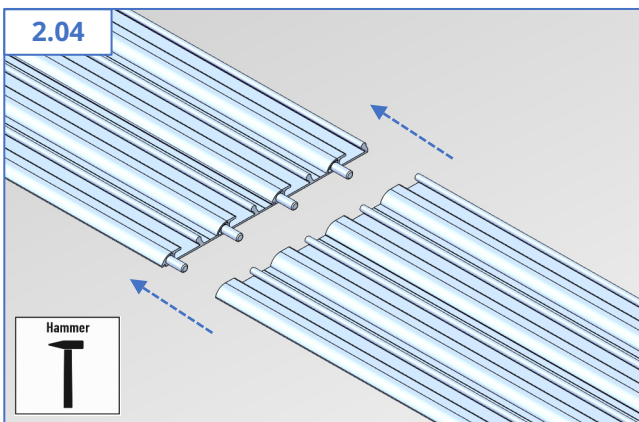
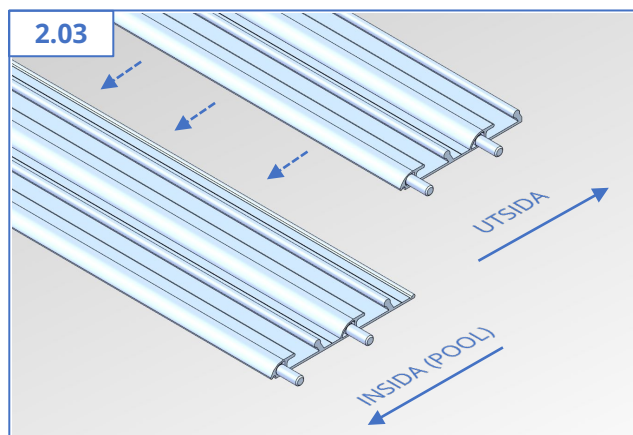
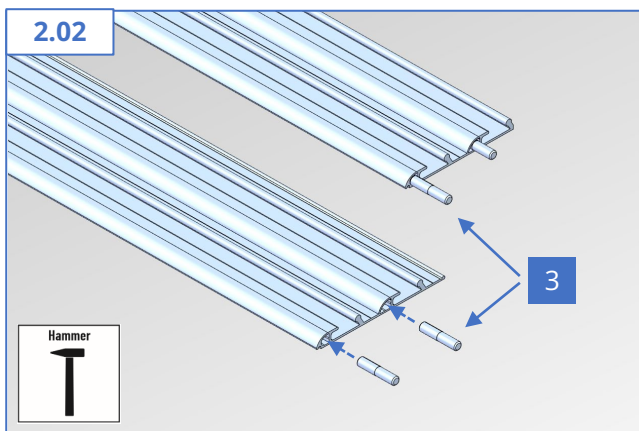

På hårt underlag (ej trä) ska hålen borraras med 7 mm borrar och sen 10 mm borrar under skenan och minst ett djup på 60 mm

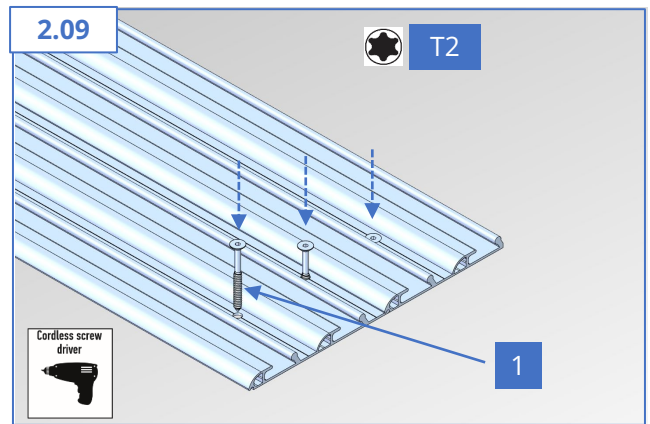
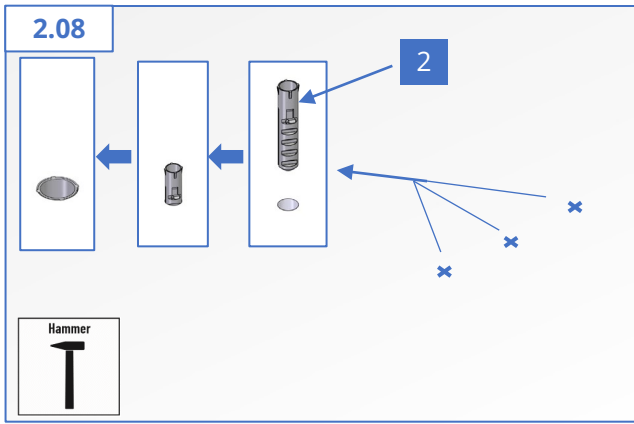

OBS! Fetta alltid in skruvarna

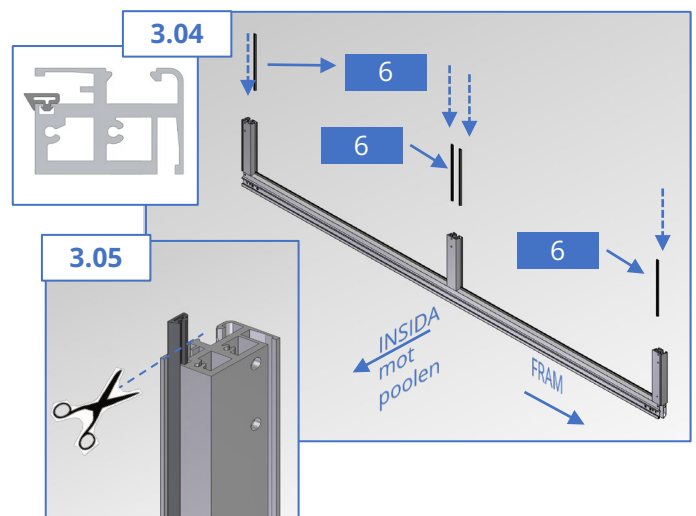
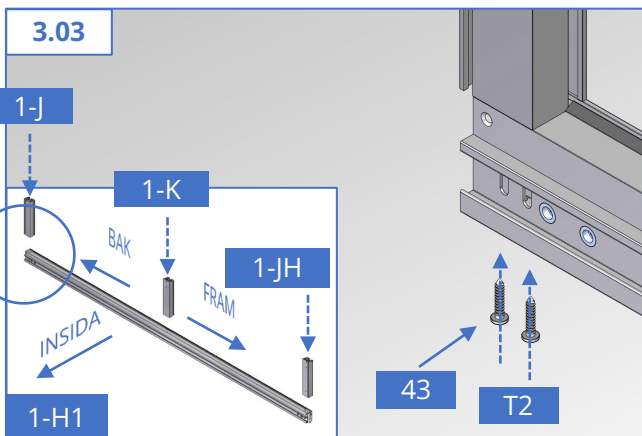
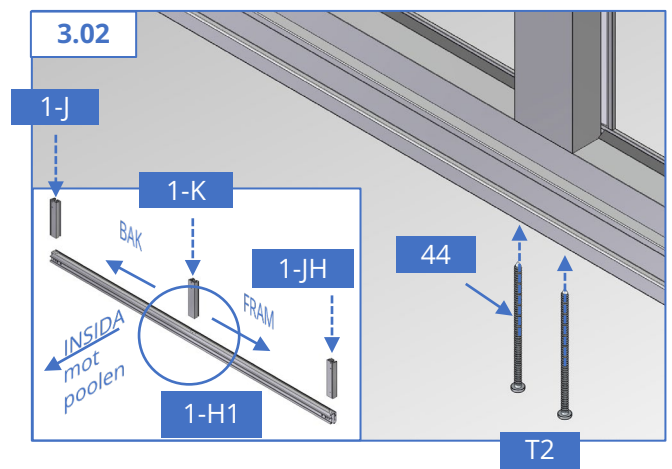
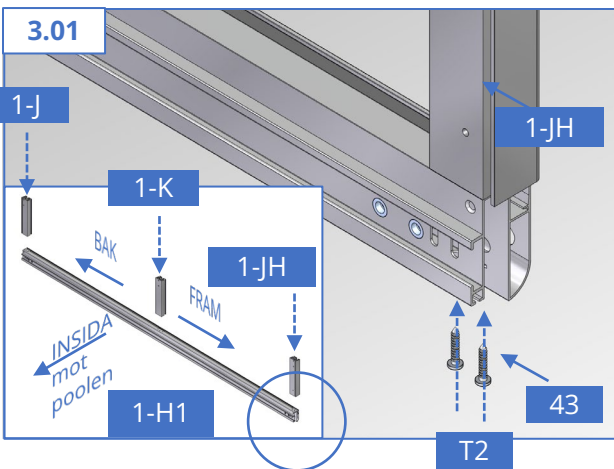

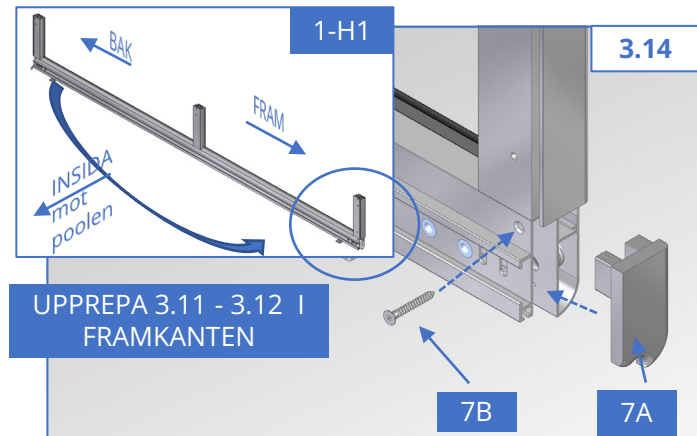
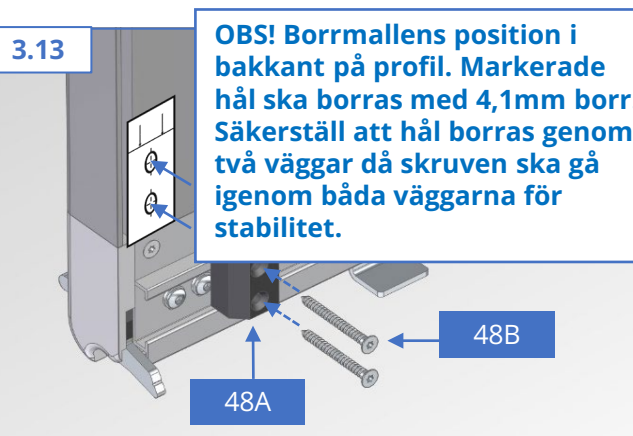
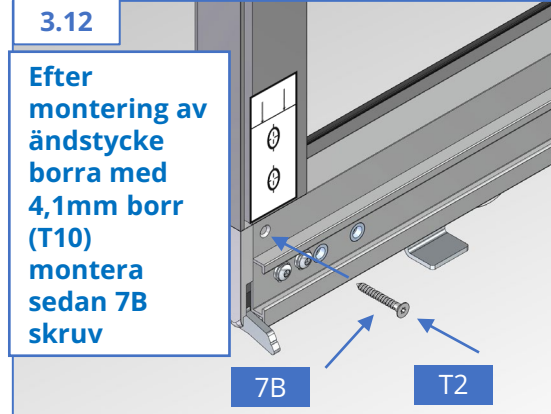
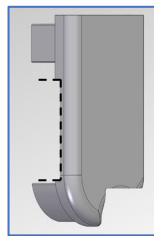
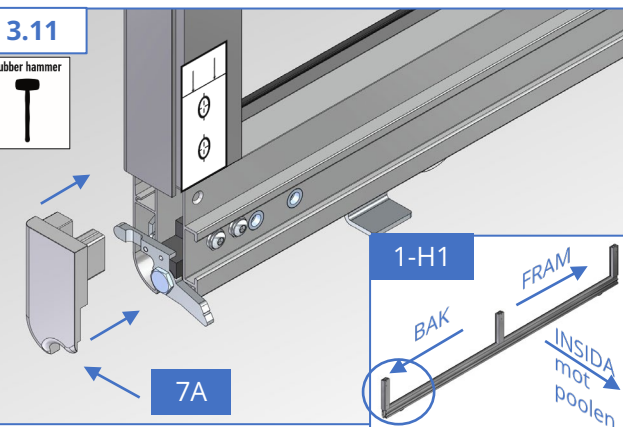
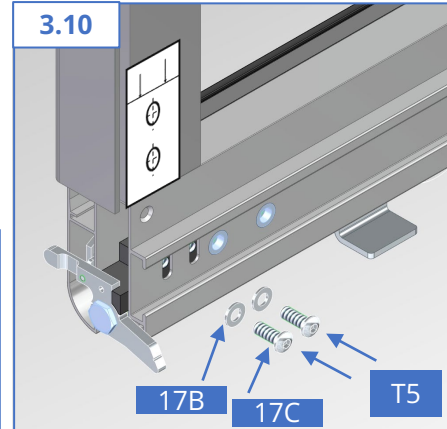
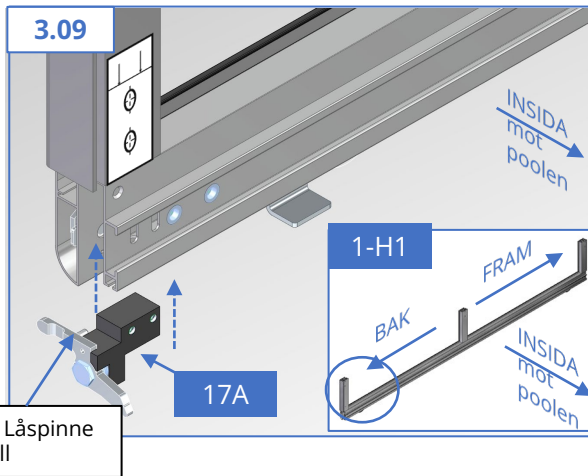
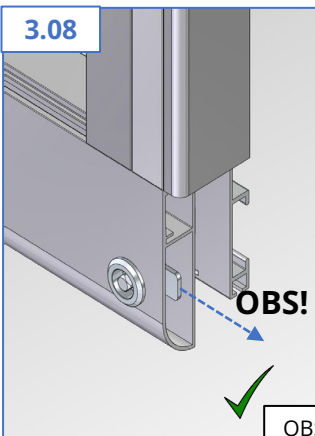
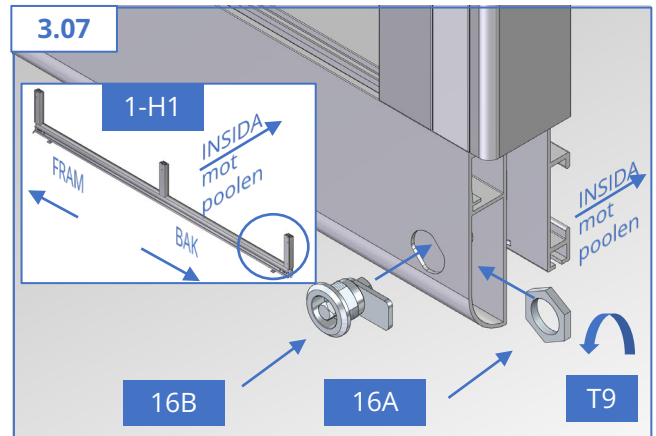
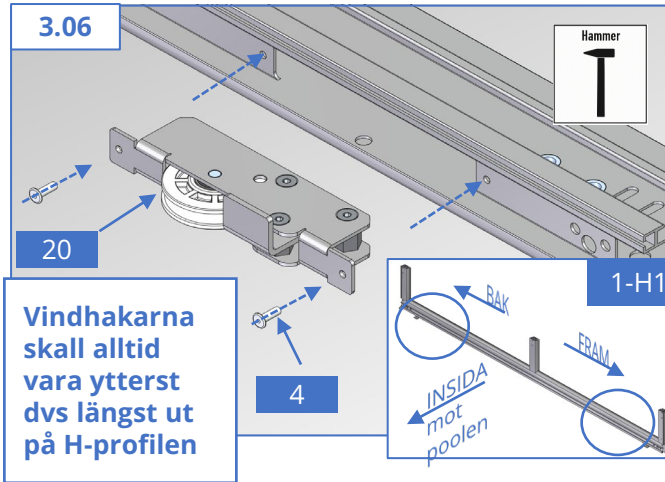

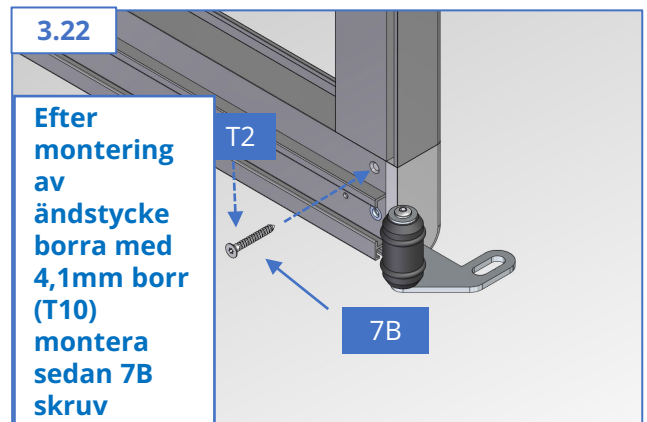
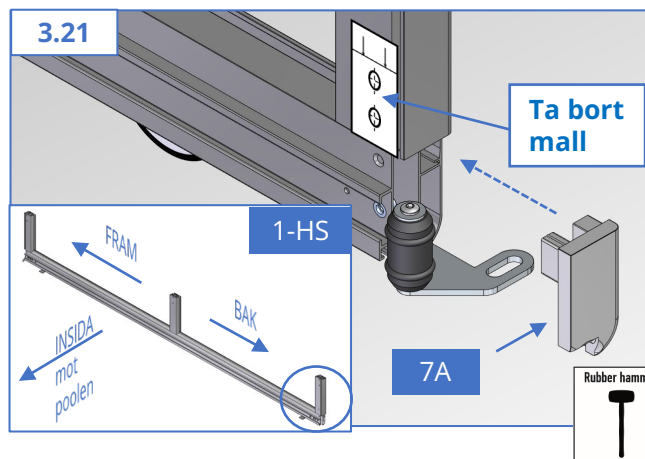
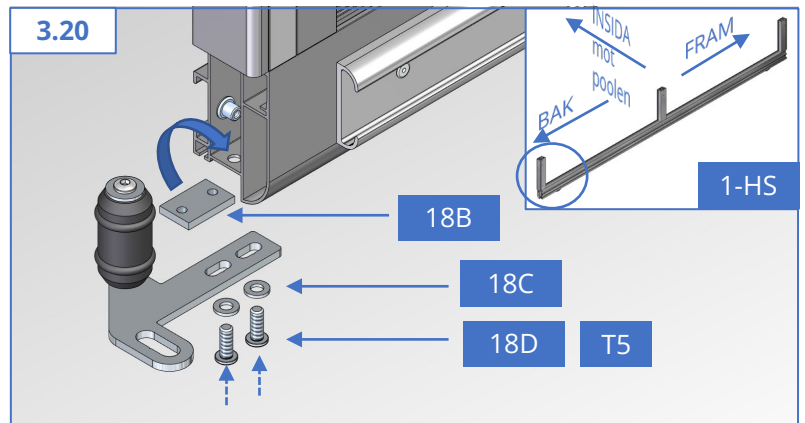
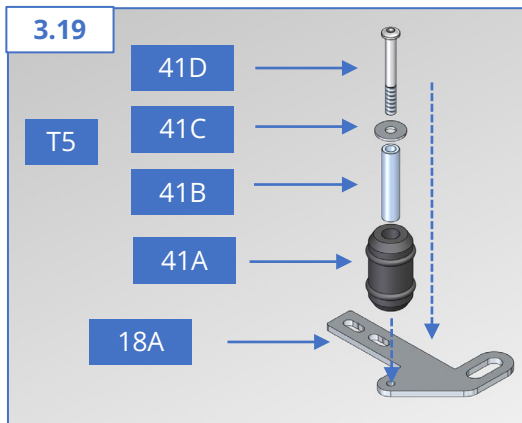
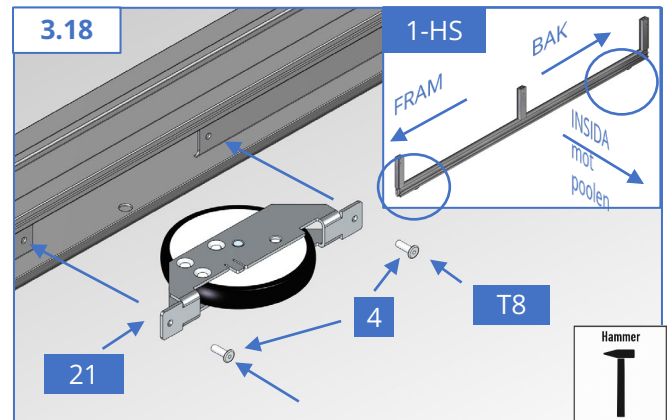
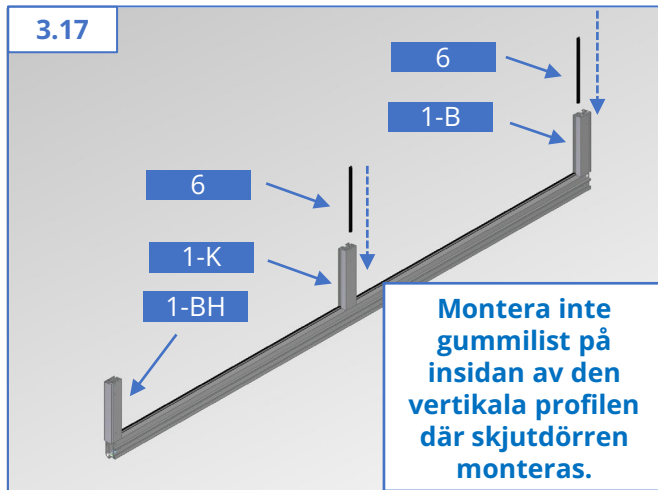
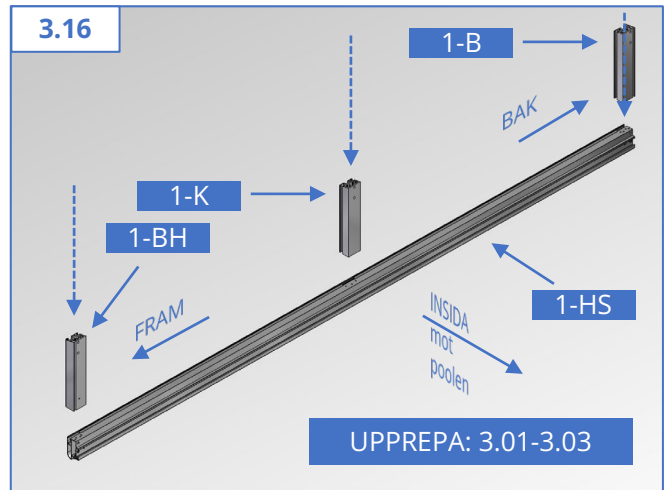
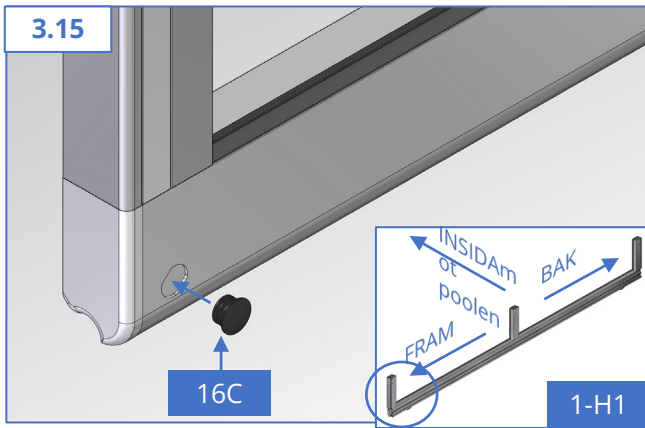

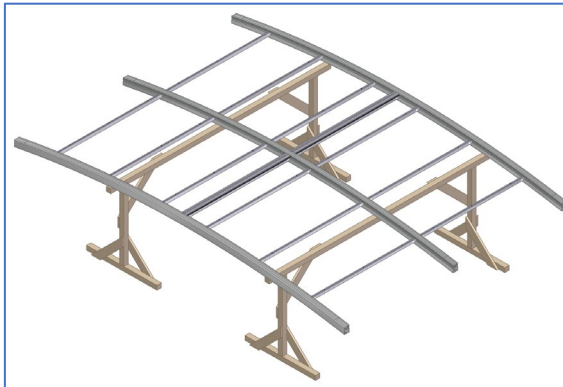
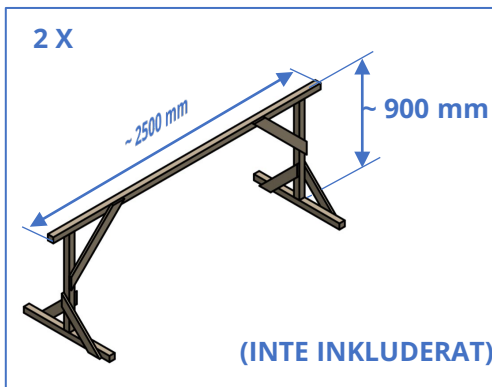
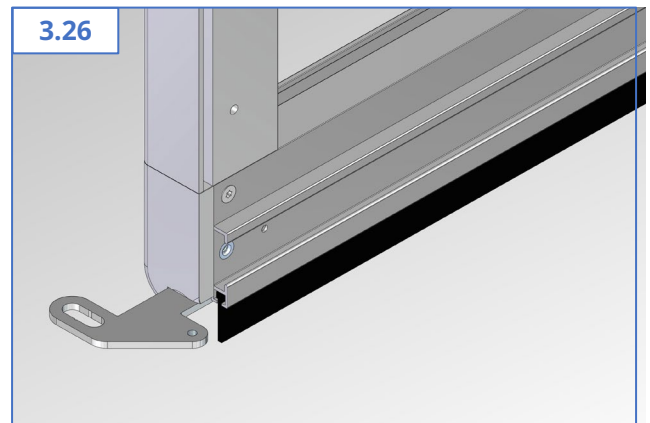
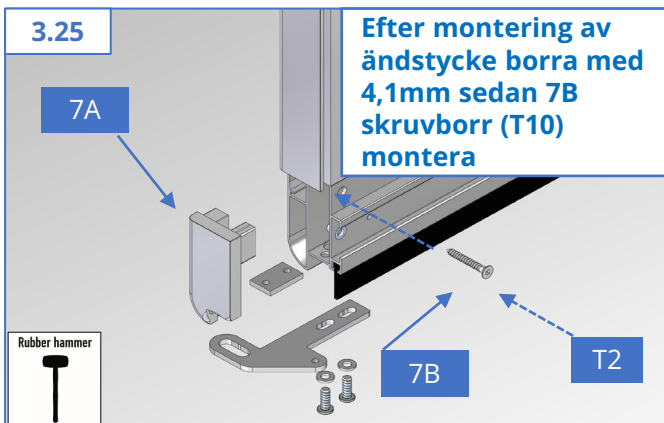
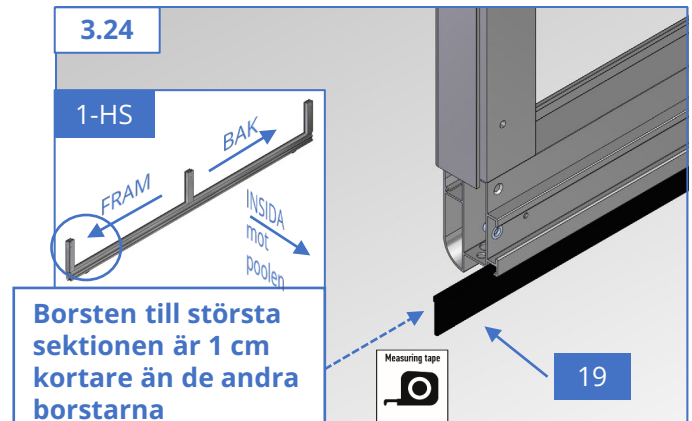
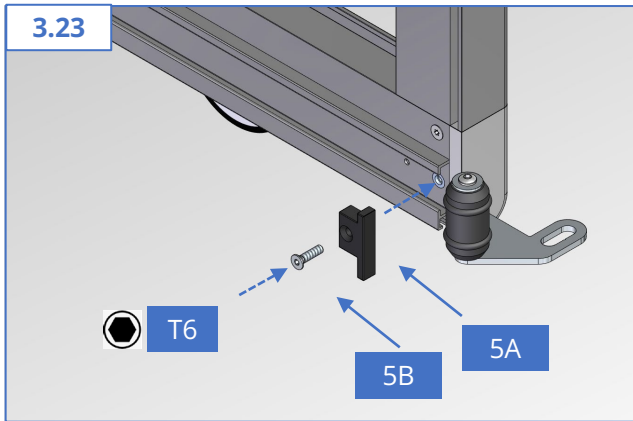

Vi rekommenderar för säkert och ergonomiskt arbete att följande moment utförs på bockar, som inte är inkluderade i boxen!

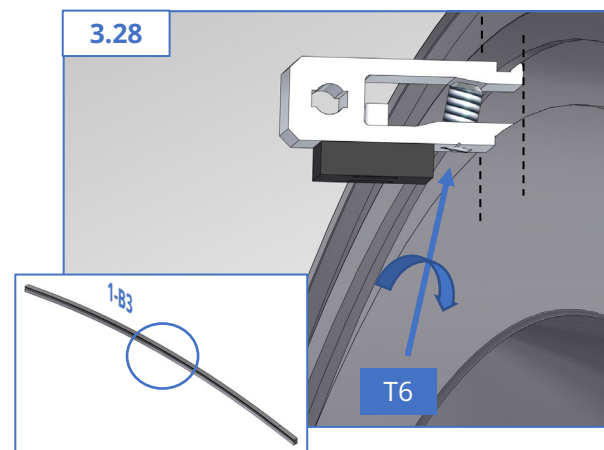
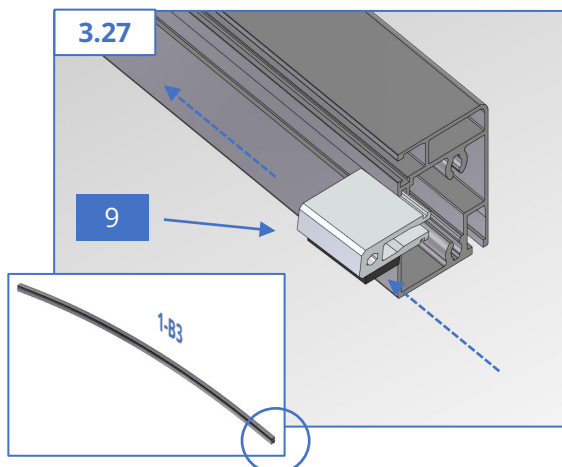



3.29

Leia 3x6- 3 st / sida
Leia 4x8 med/utan sarg

1-B3

8

3.30

T6

3.31

UPPREPA: 3.28

3.32

UPPREPA: 3.30

Efterjustera och säkerställ att fästena linjerar mot varandra i bågprofilerna

3.33

UPPREPA: 3.28

3.34

UPPREPA: 3.30

3.35

DÖRR

Klipp av insidans
gummlist (nr 6) och ta
bort det från profilen
1-B1 och 1-B2 där
skjuddörren monteras.

3.36

DÖRR



3.37

Insidans gummilist (nr 6) skall vara placerad på motsatt sida (på G-profilen) från skjutdörren. Flytta listen om det behövs

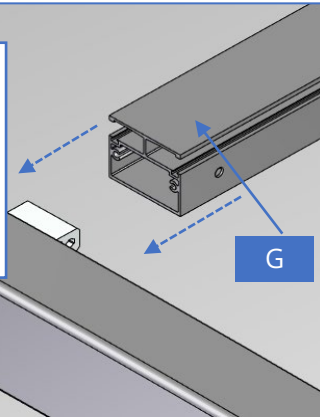

3.38

Hålen "blundar" lite för att tvinga ihop profilerna för bästa passform.

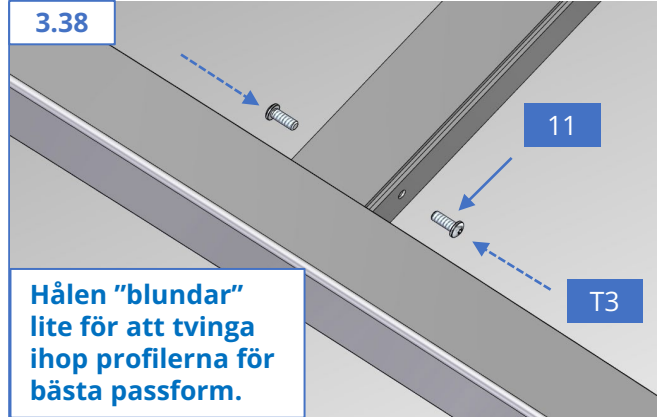

3.39

Z

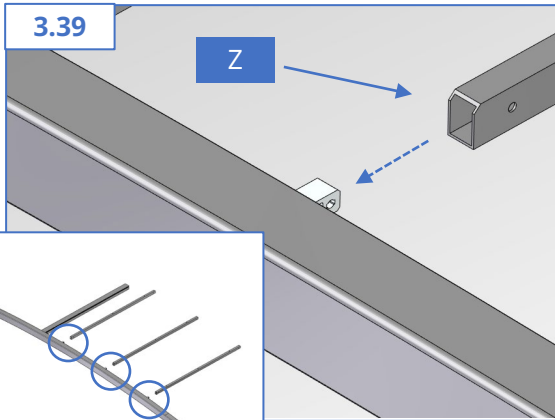
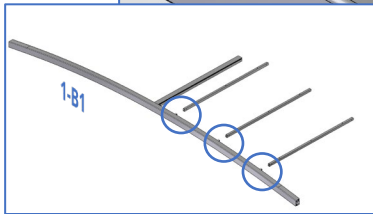

3.40

10

T3

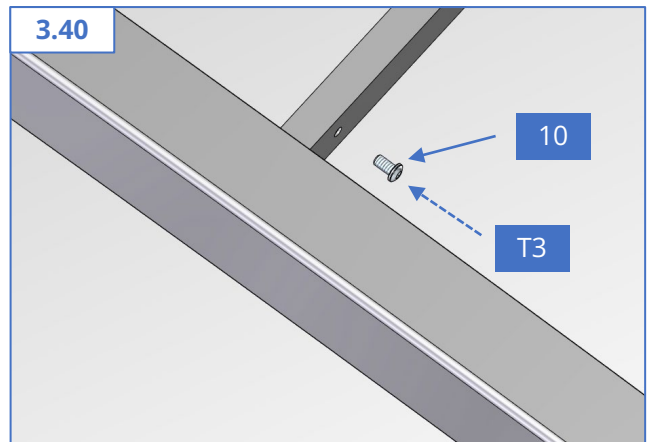

3.41

1-B2

Montera bågprofilen på Z-profilerna en och en från ena änden till andra.

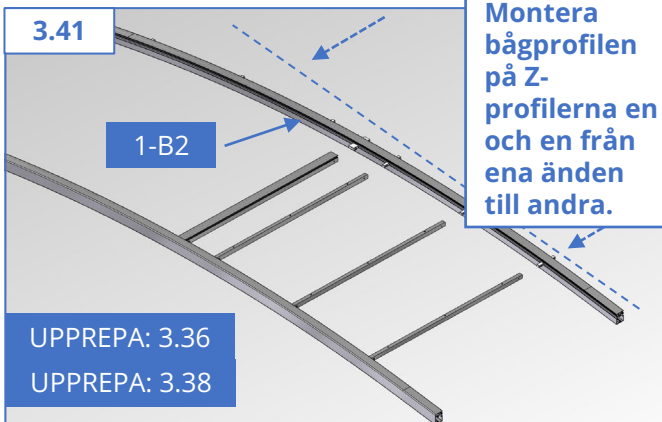

UPPREPA: 3.36

UPPREPA: 3.38

3.42

G-S

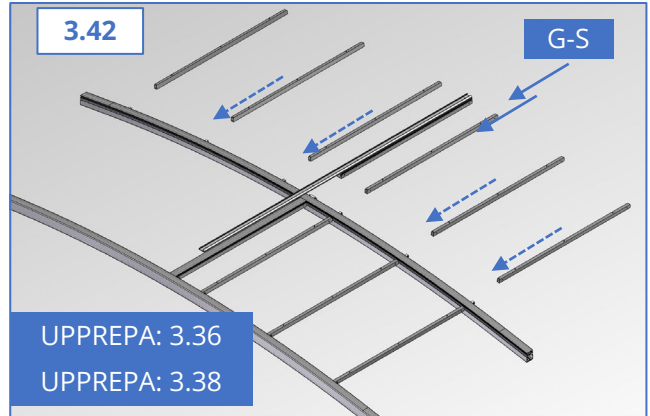

UPPREPA: 3.36

UPPREPA: 3.38

3.43

1-B3

UPPREPA: 3.36

UPPREPA: 3.38

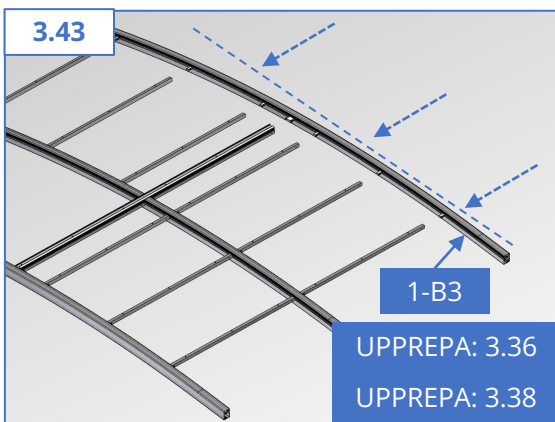

3.44

T8

4

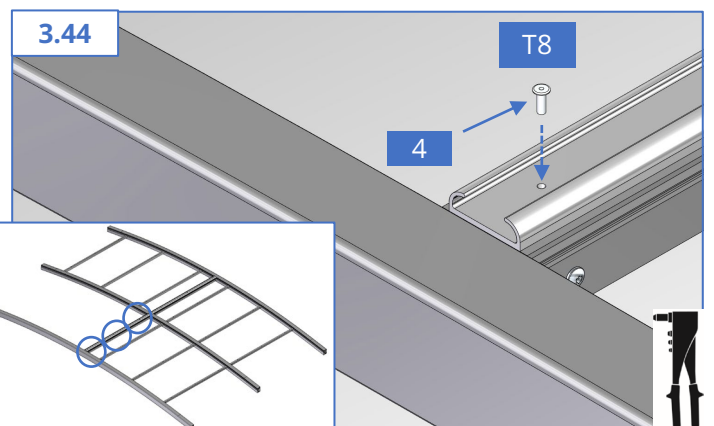
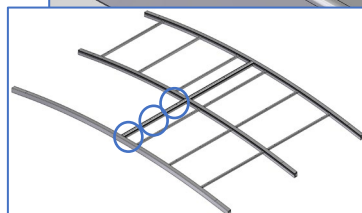

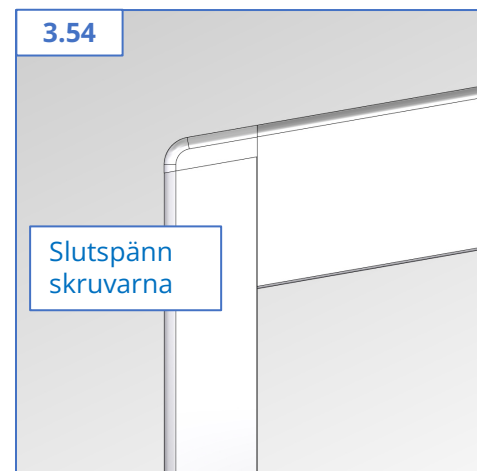
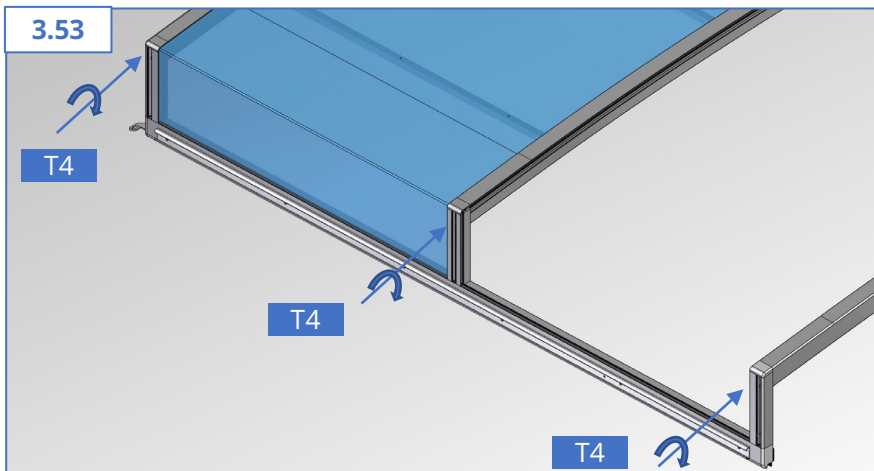
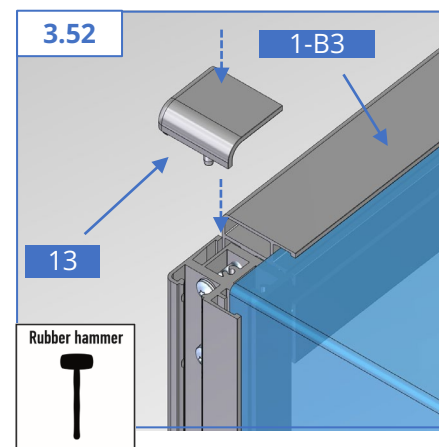
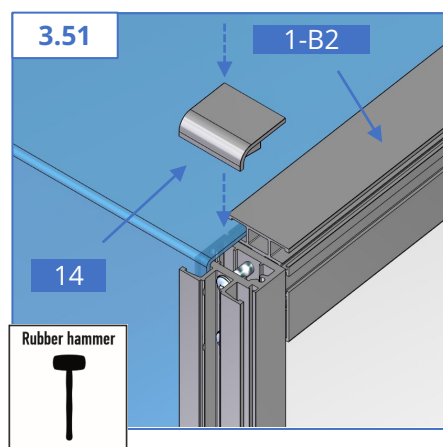
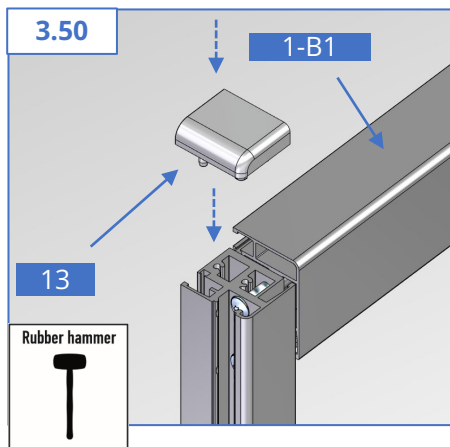
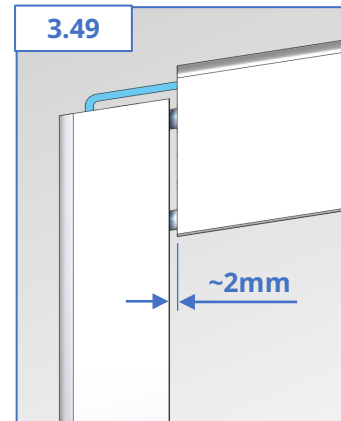
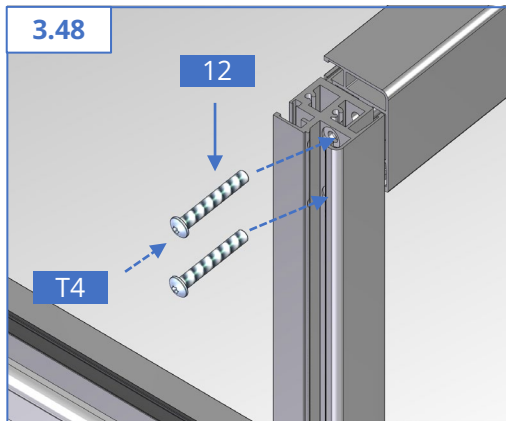
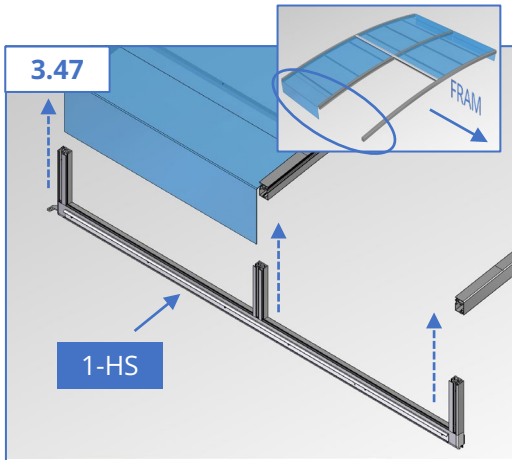
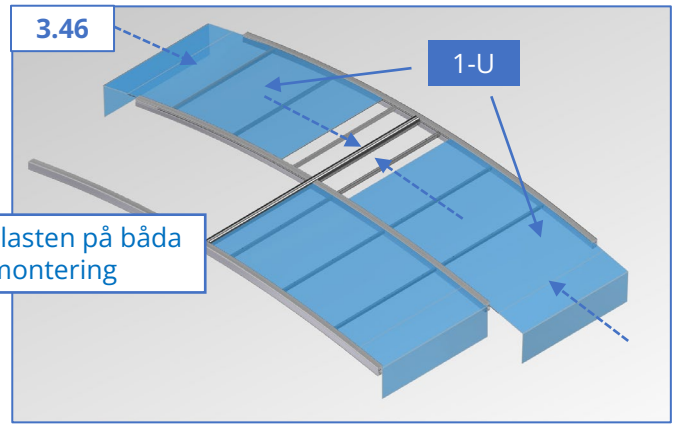
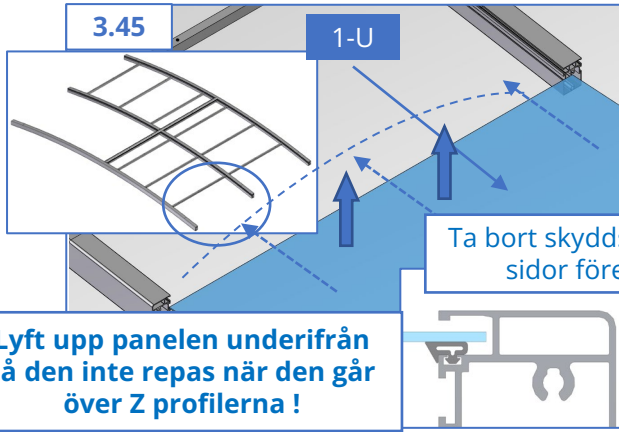

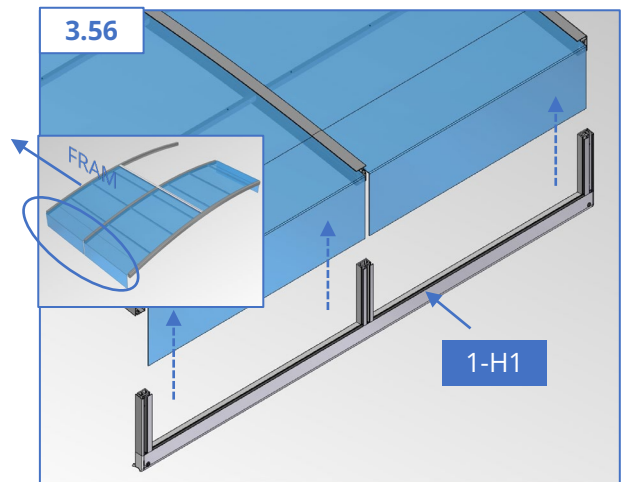
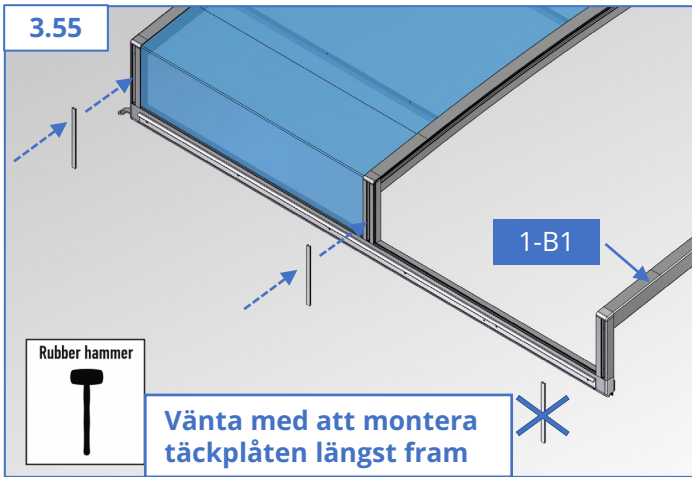

UPPREPA: 3.45 – 3.56

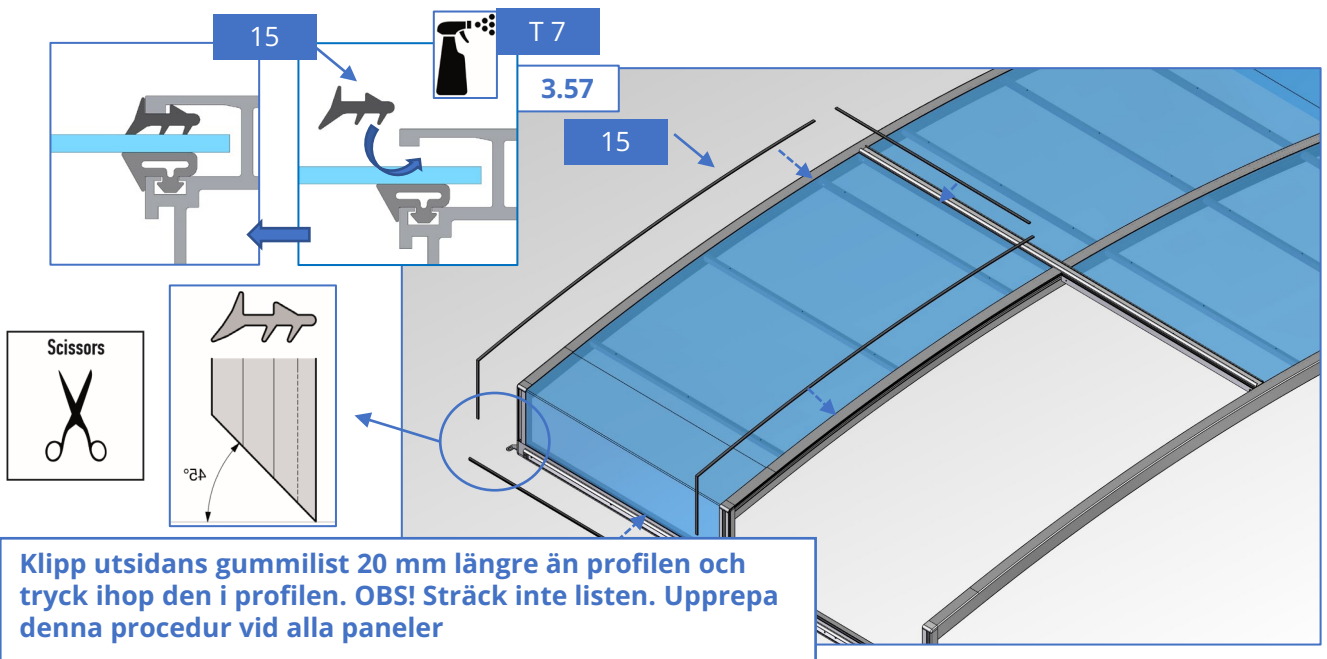

Kör på största sektionen först därefter de övriga sektionerna i fallande ordning

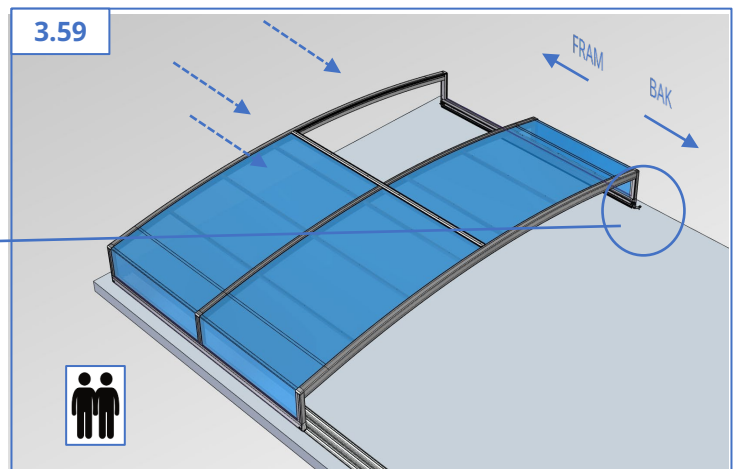
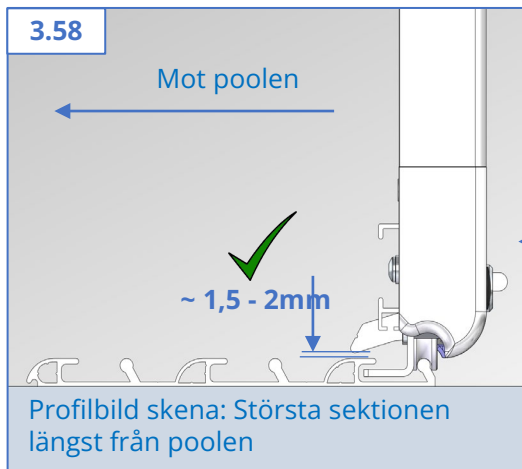



X*= Vilken sektion räknat från den största
Ex. andra sektion = 2-K

4.01

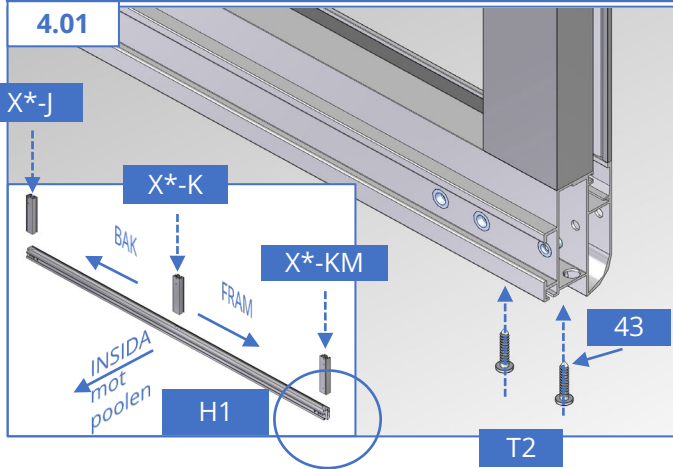

4.02

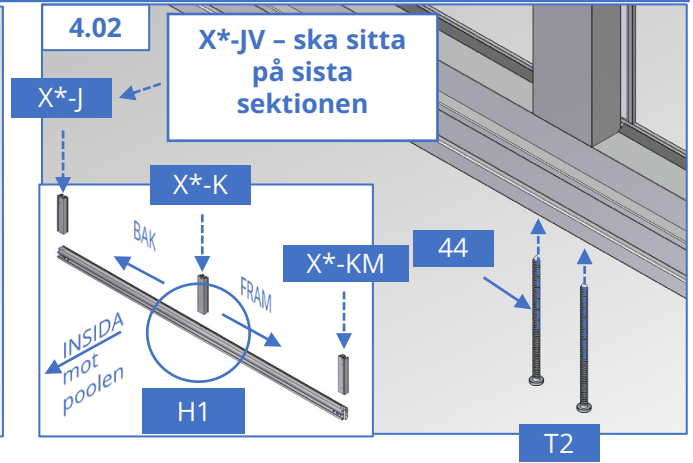

OBS! Säkerställ att X*KM profilen på **skensidan** har bormallen på utsidan längst fram

4.03

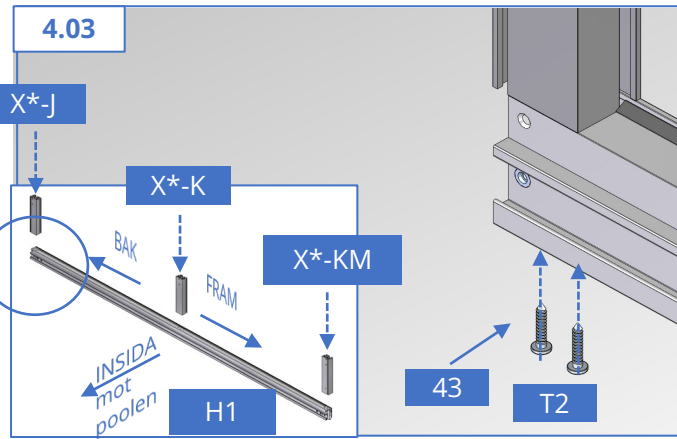

4.04

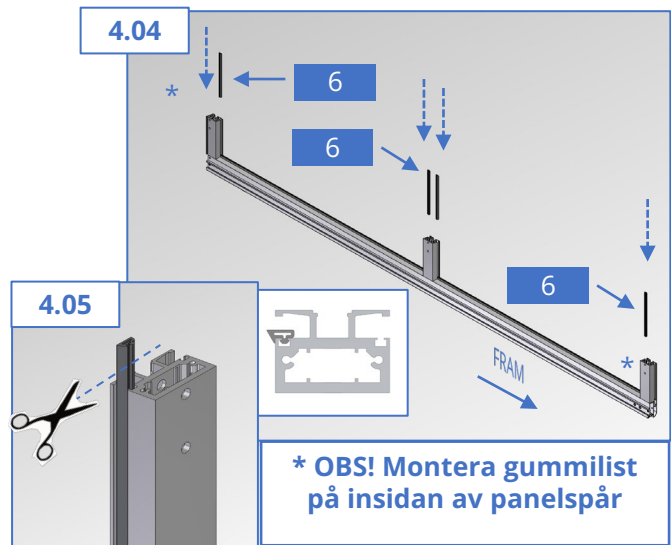

4.05

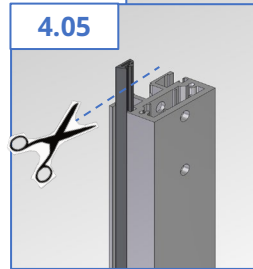

4.06

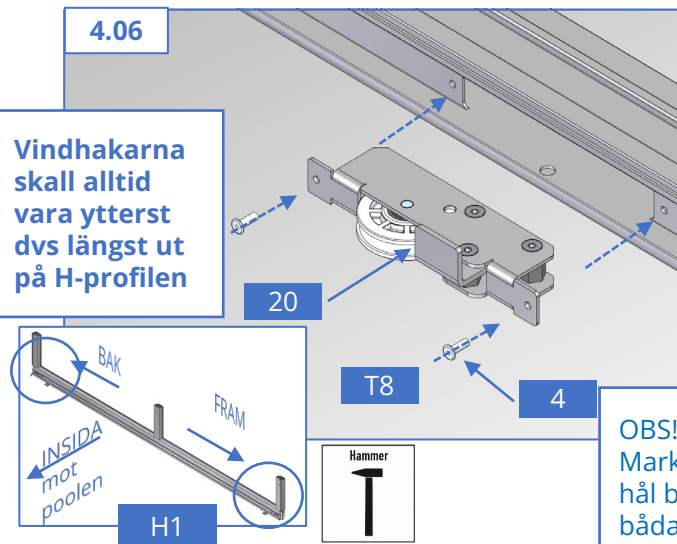

4.07

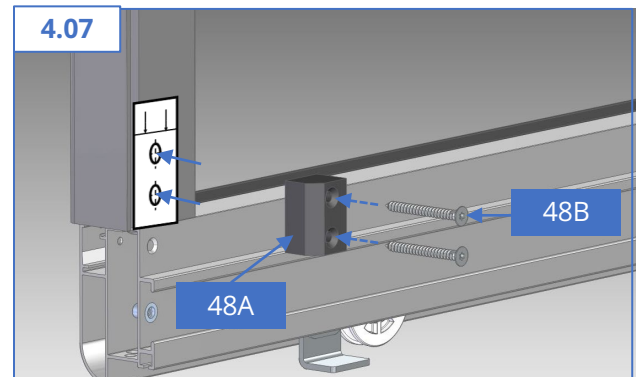

OBS! Mallens position i bakkant på profilens insida. Markerade hål ska borraras med 4,1mm borrar. Säkerställ att hål borraras genom två väggar då skruven ska gå igenom båda väggarna. Sektionsklossen behöver inte monteras på insidan på minsta sektionen.

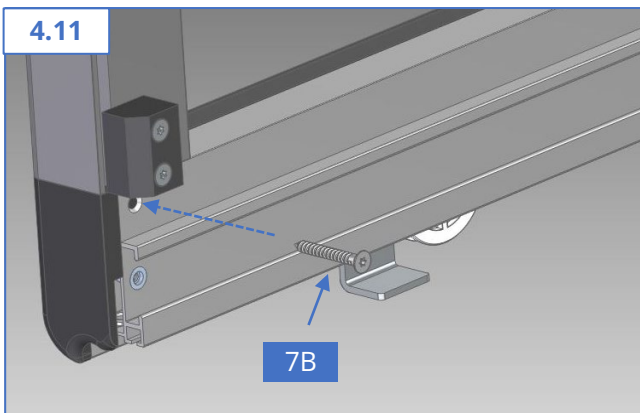
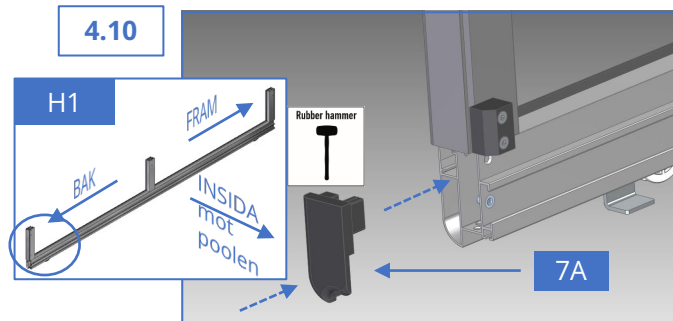
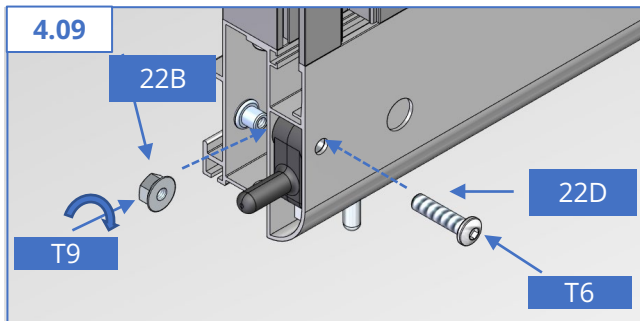
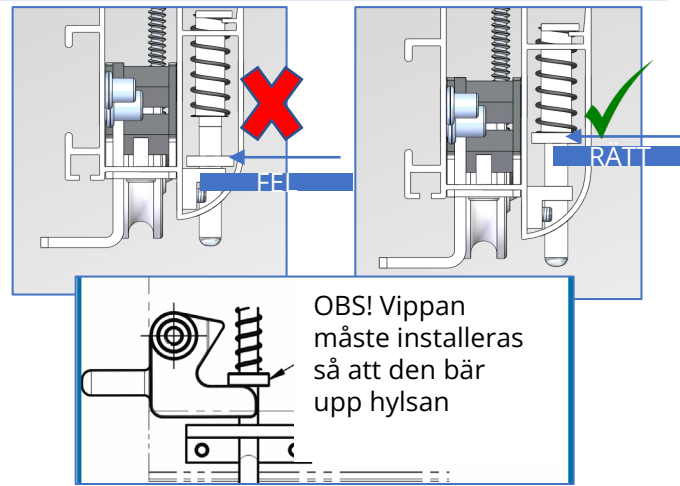
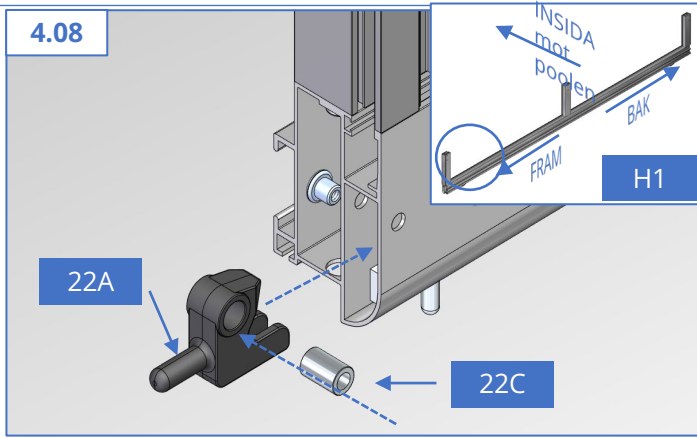

Efter montering av ändstycke borra med 4,1mm borrh (T10) montera sedan 7B skruv

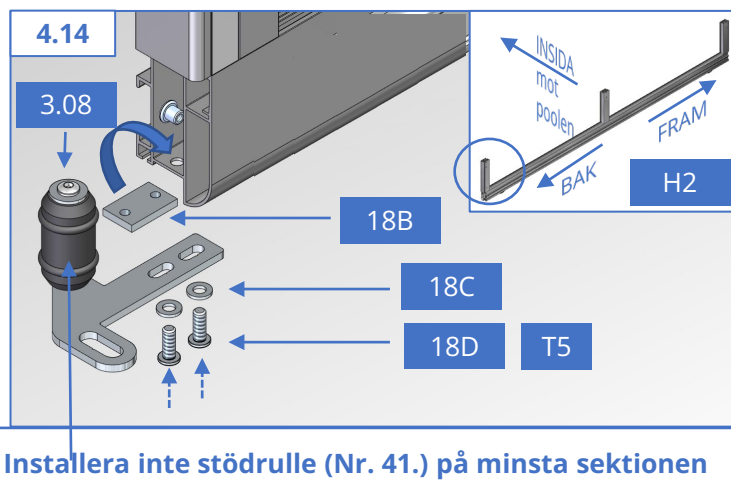
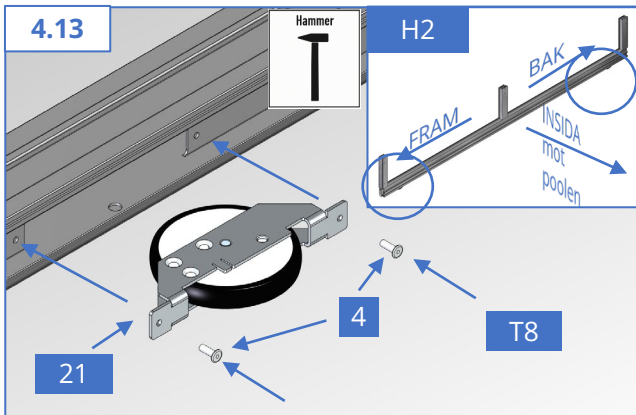
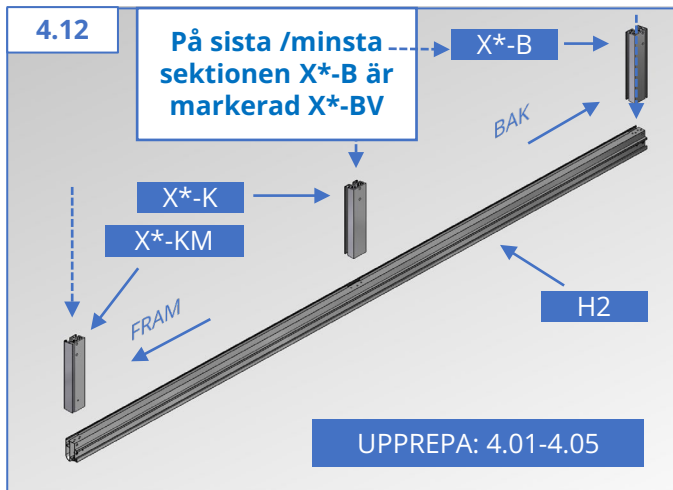

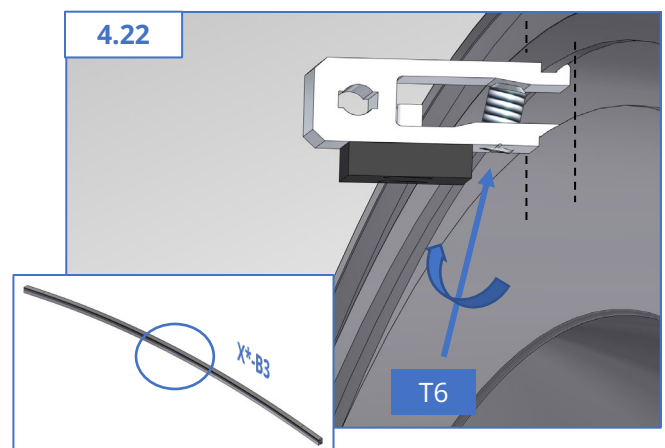
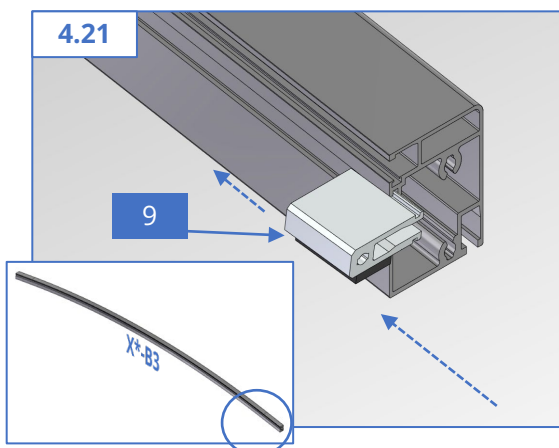
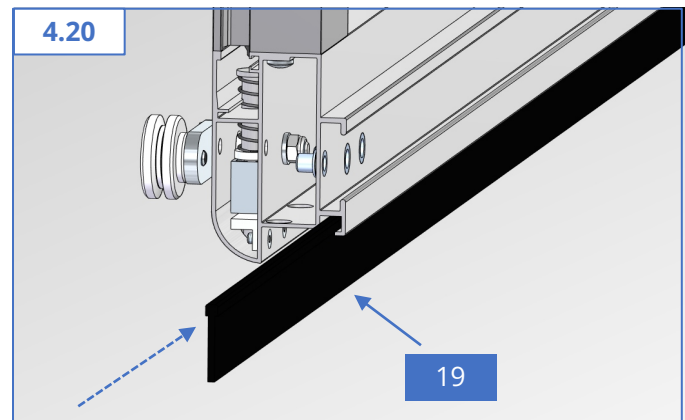
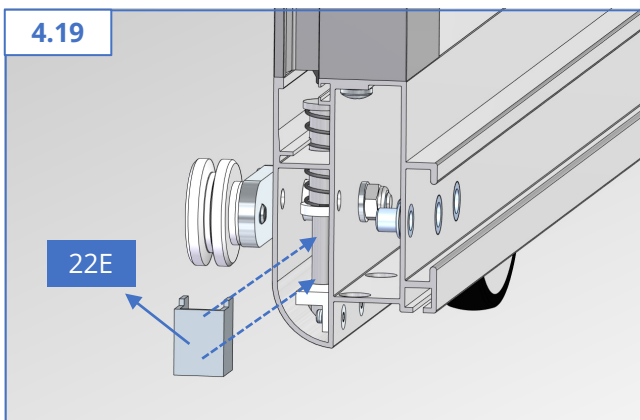
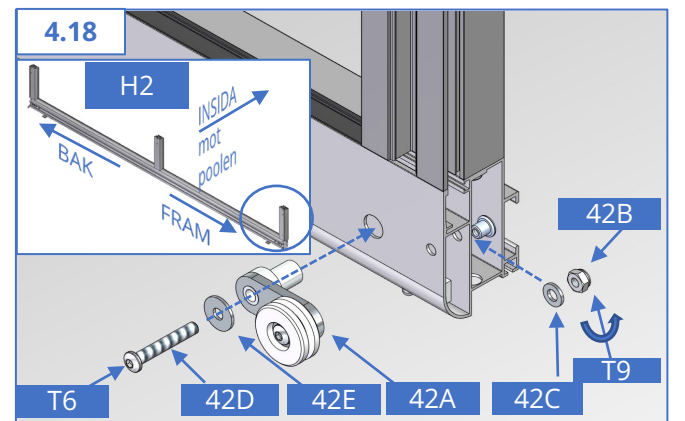
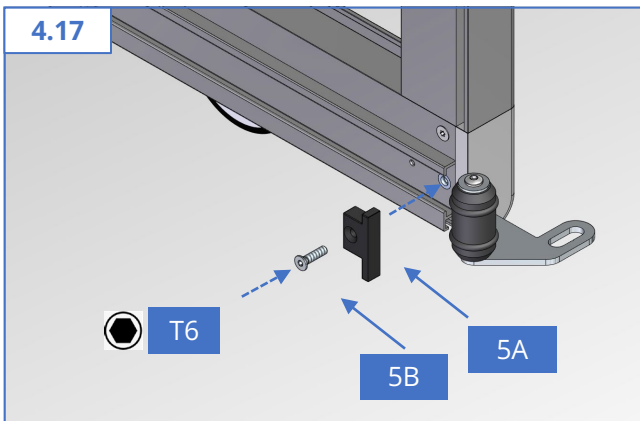
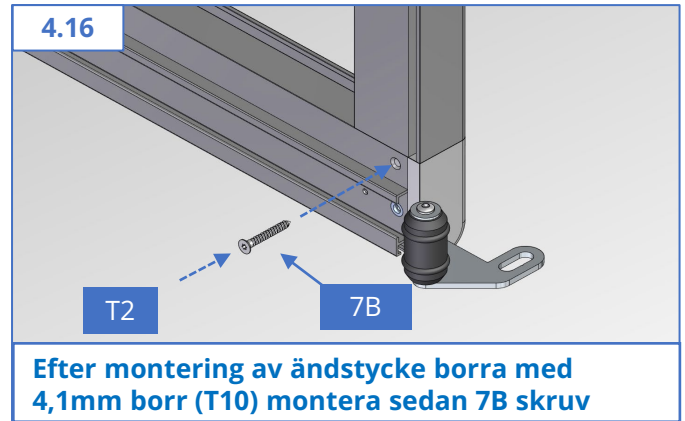
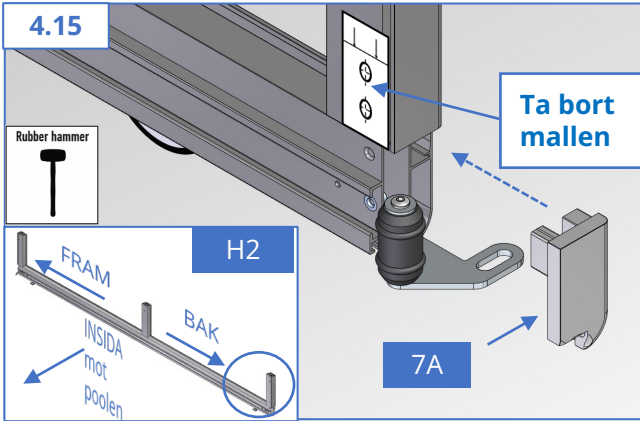

X*= Vilken sektion räknat från den största Ex. 2. sektionen = 2-B3



4.23

Leia 3x6- 3 st / sida
Leia 4x8 med/utan sarg- 4 st / sida

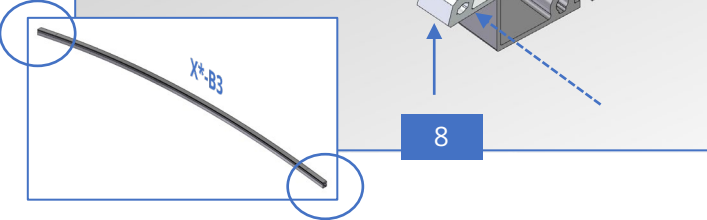

4.24

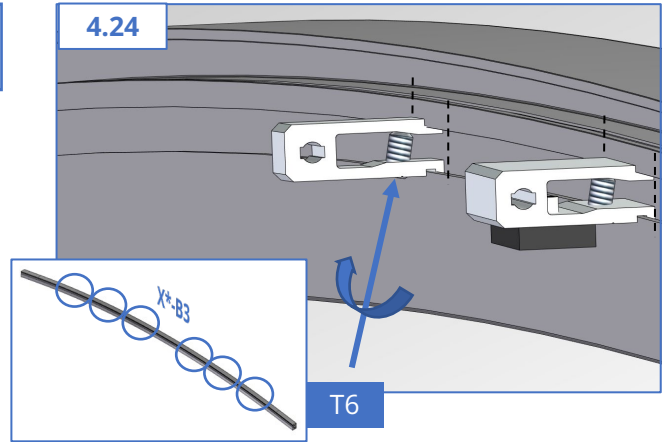

4.25

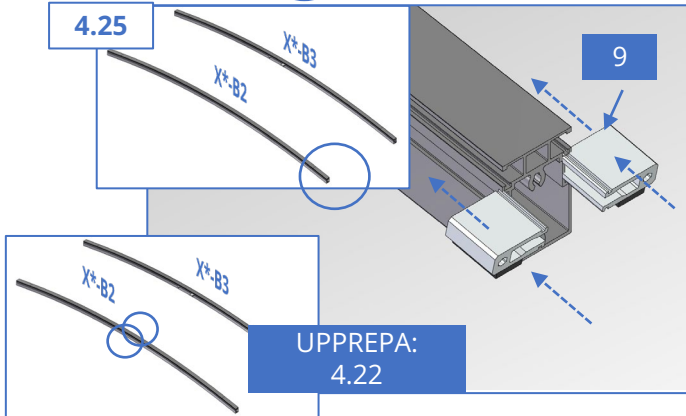

4.26

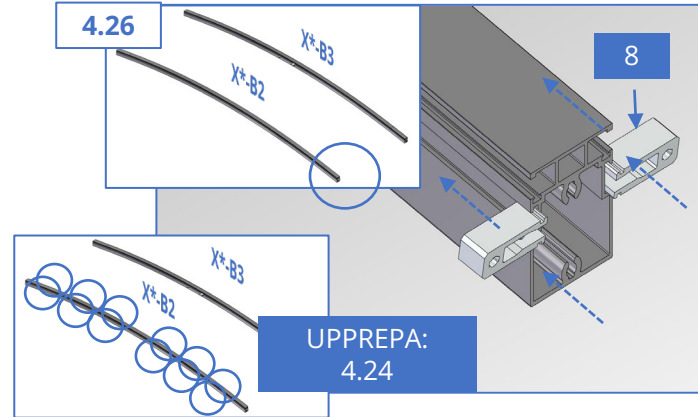

4.27

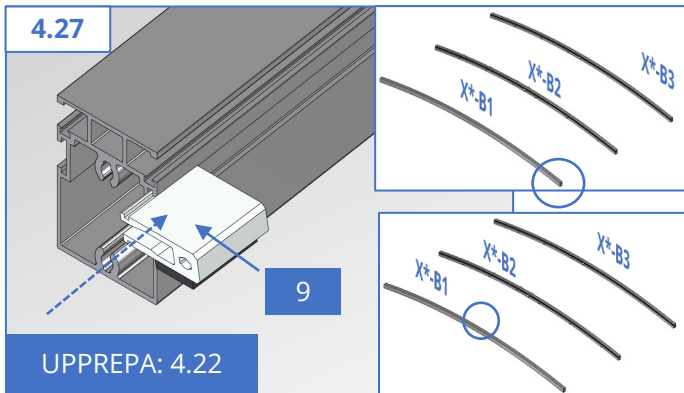

4.28

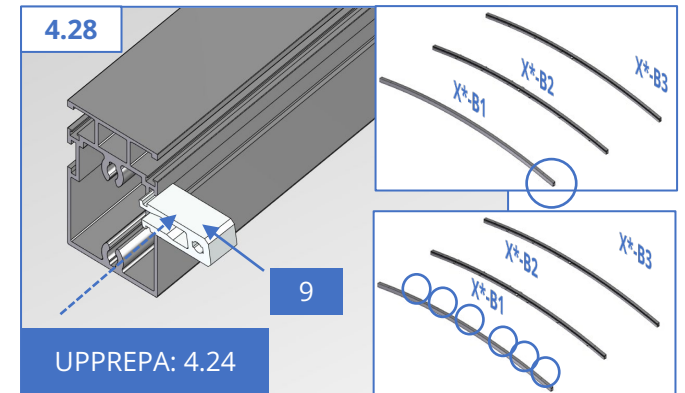

4.29

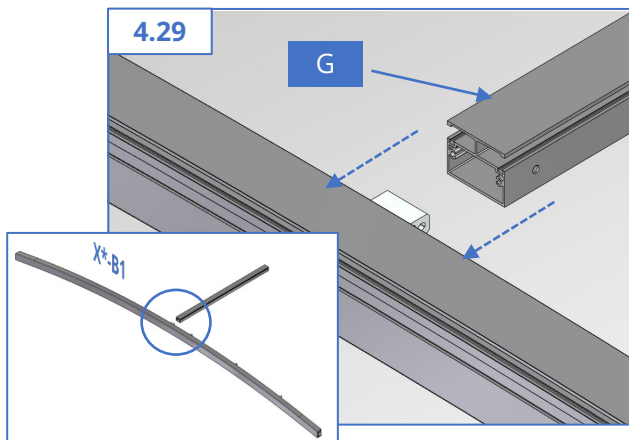

4.30

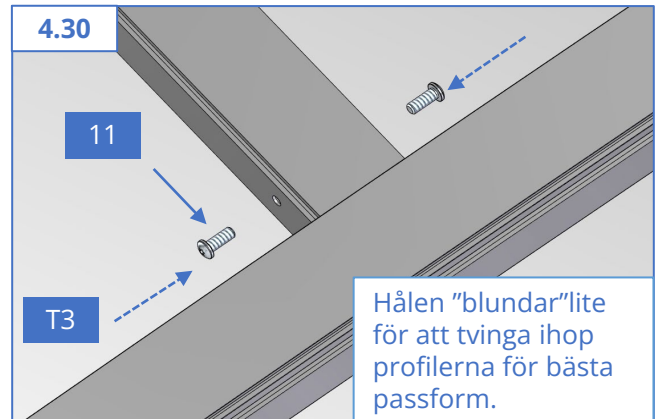

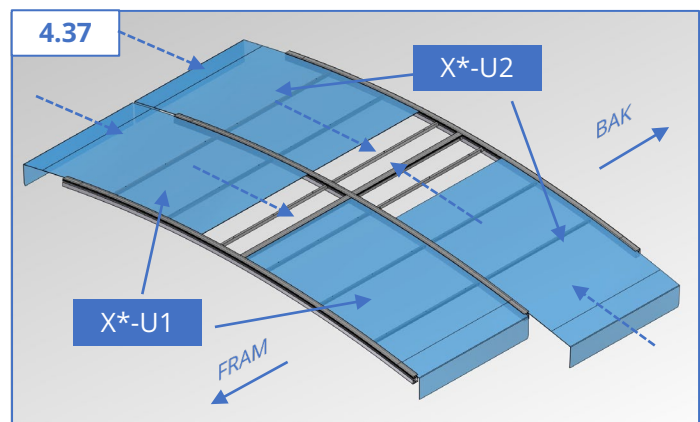
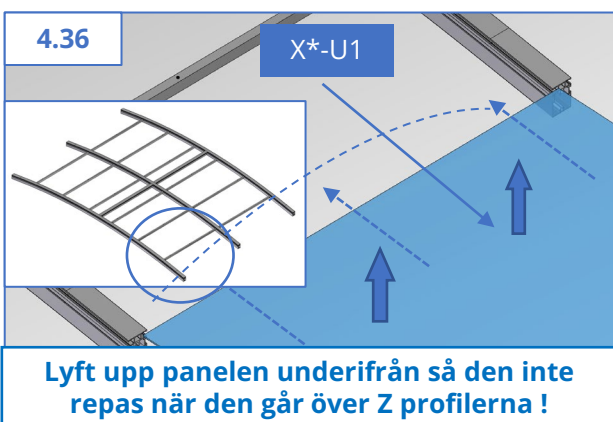
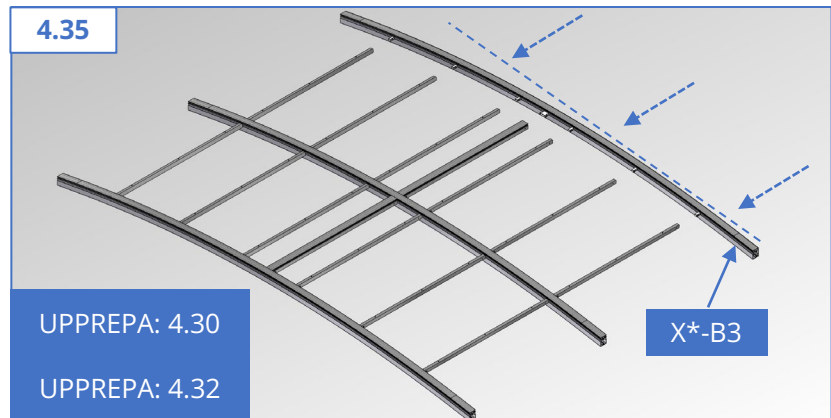
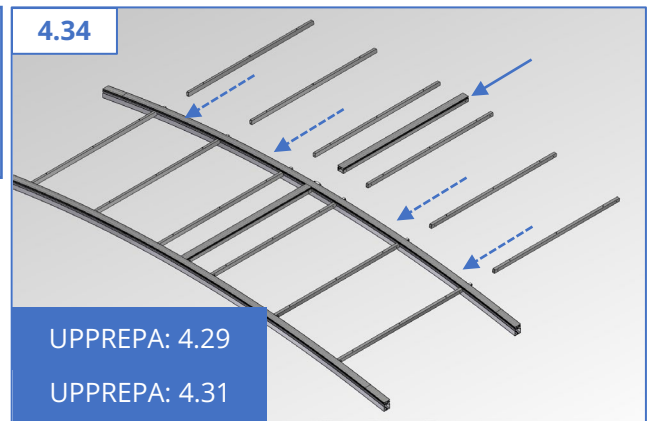
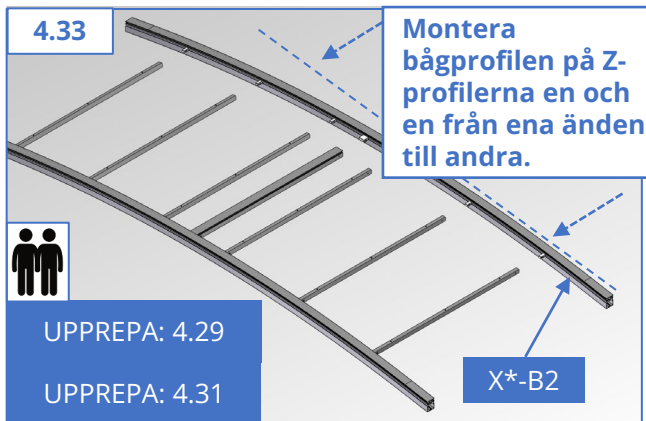
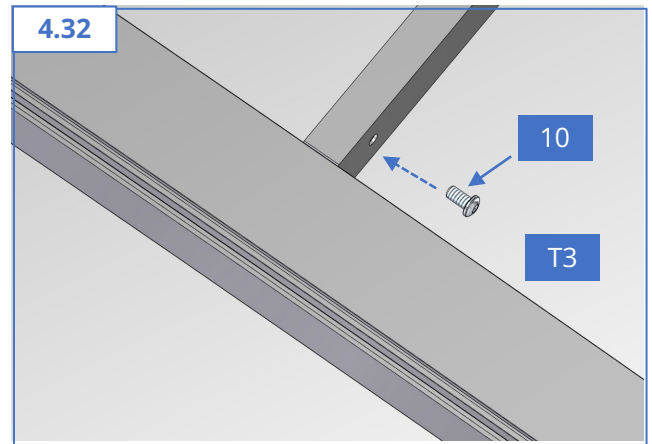
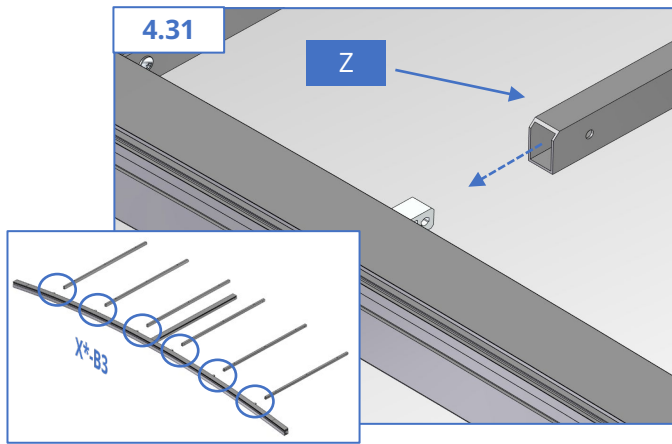

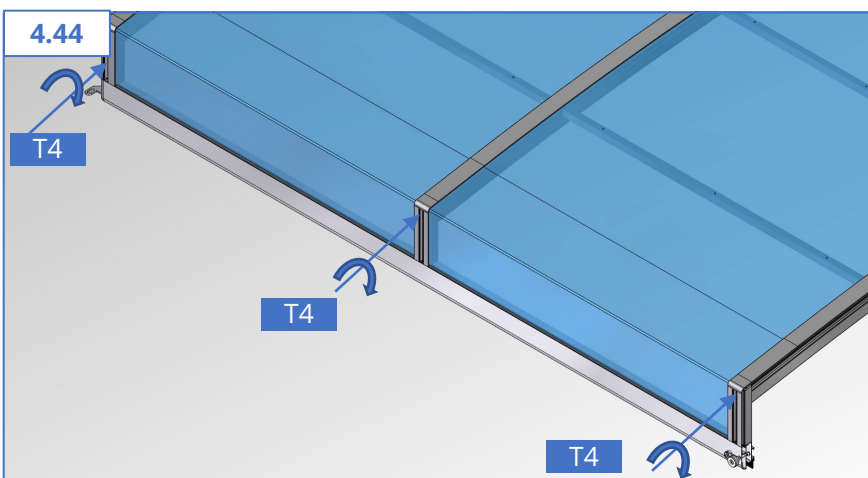
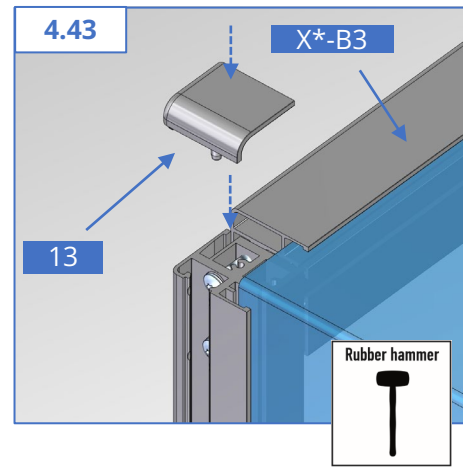
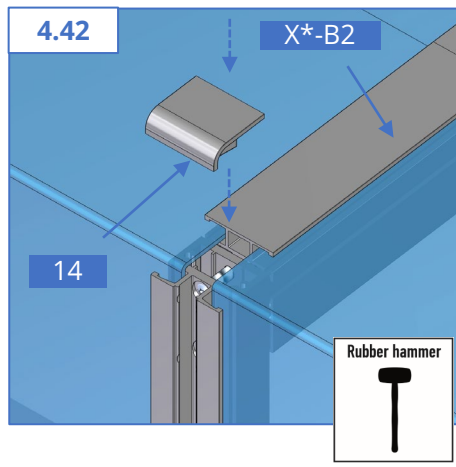
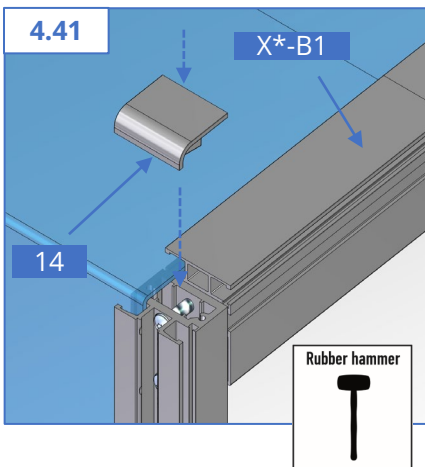
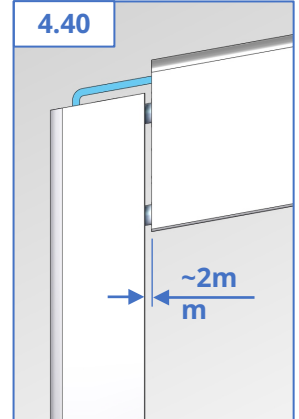
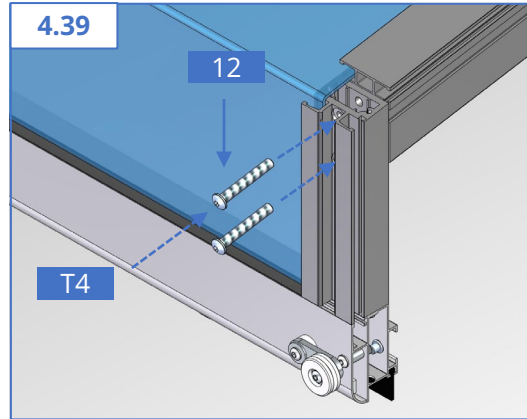
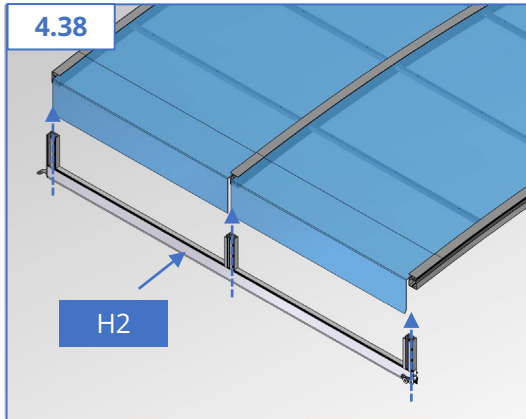

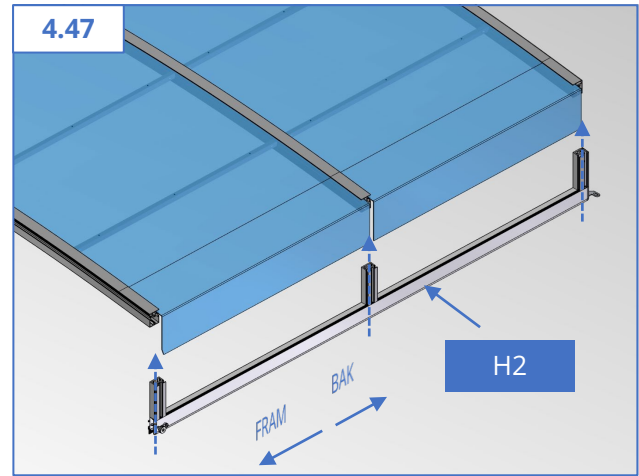
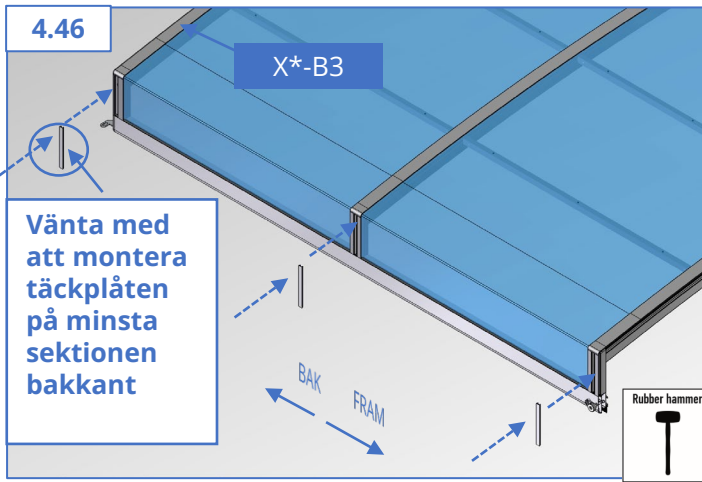

UPPREPA: 4.39 – 4.46

Montera gummilist utsida på samtliga sektioner enl bild 3.54

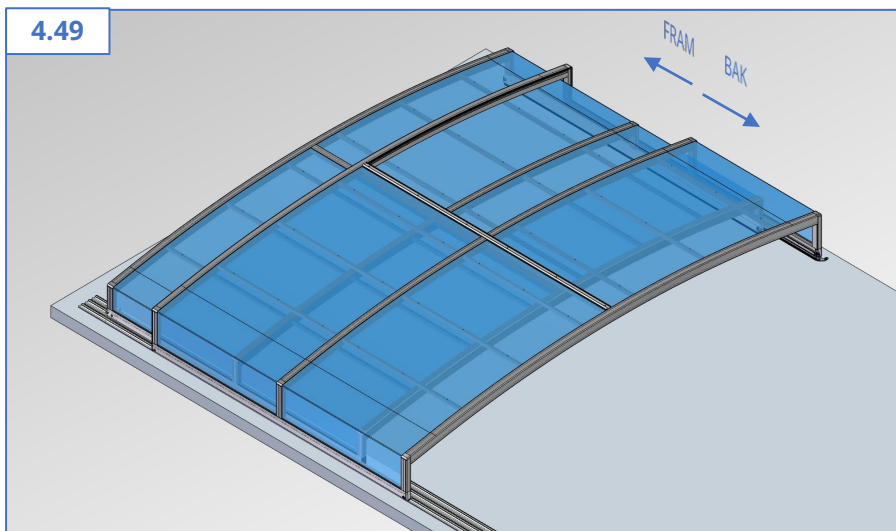
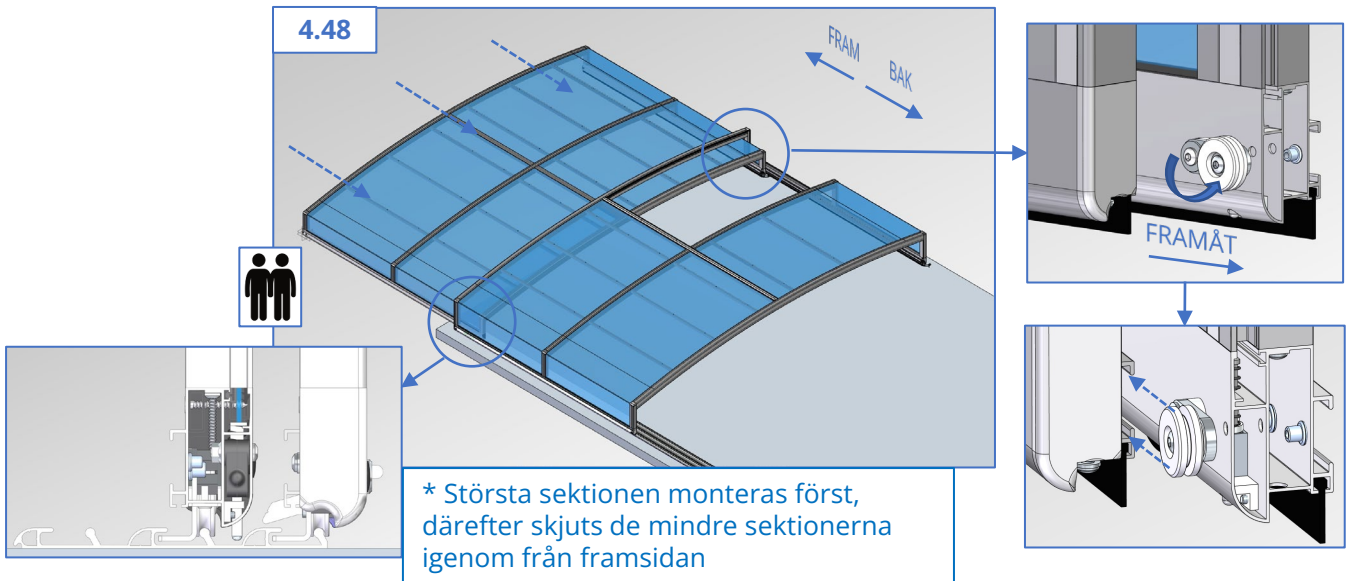

Montera samtliga mellansektioner enligt 4.01 – 4.48

Observera följande punkter vid montering av den minsta sektionen 4.02, 4.07, 4.14, 4.46.

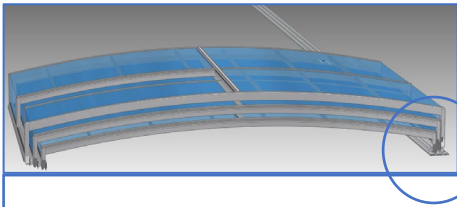

Markerade hål ska borraras med 4,1mm borrar enl. mall. Säkerställ att hål borraras genom två väggar då skruven ska gå igenom båda. OBS! Säkerställ mallarnas position enligt bild 5.00
Mallen kan tas bort efteråt.

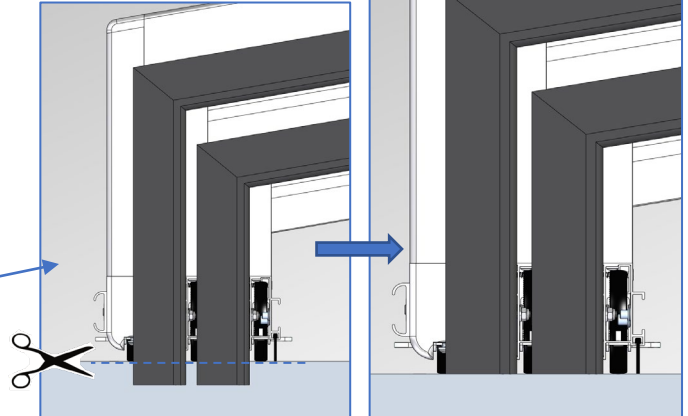
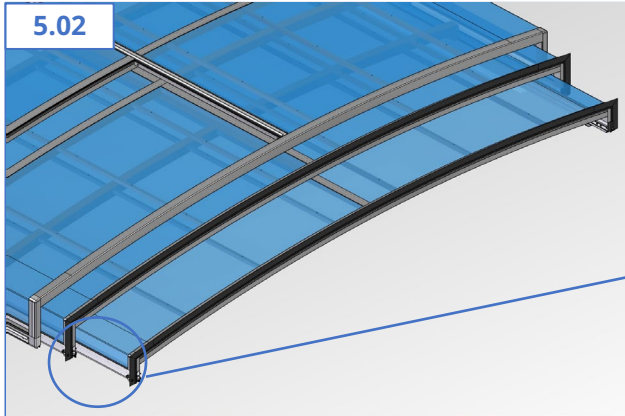
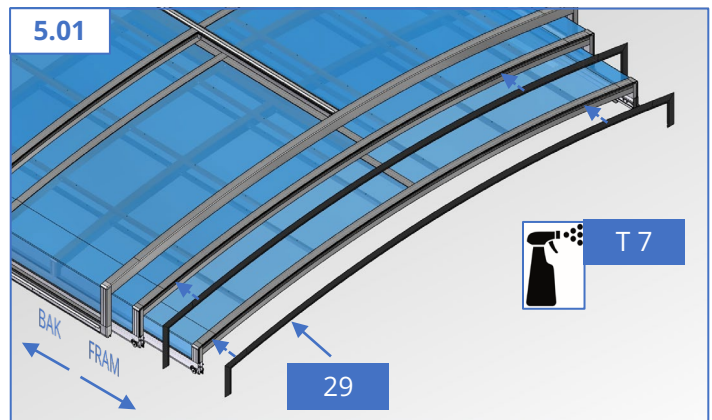
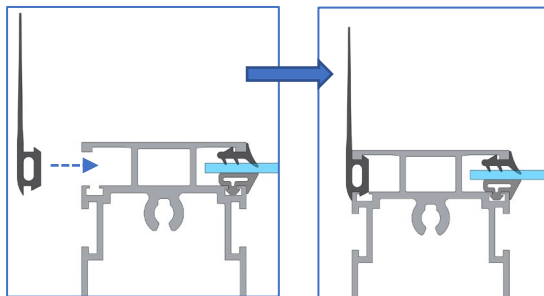
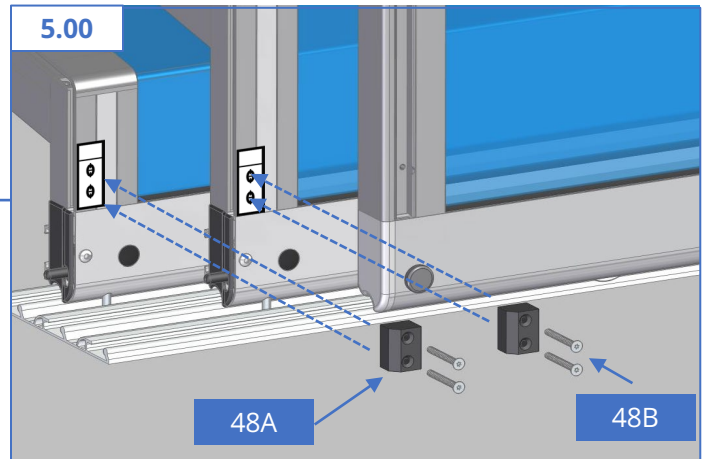

Gör en liten rundning i hörnan för att minska gummits slitage.

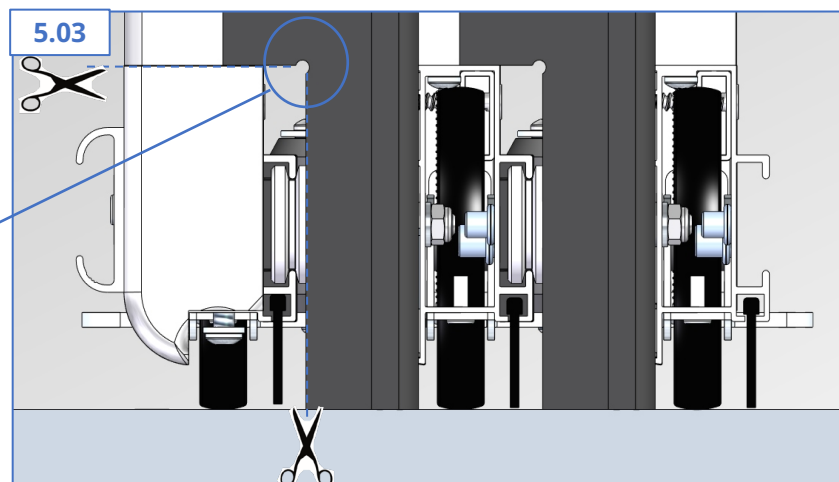

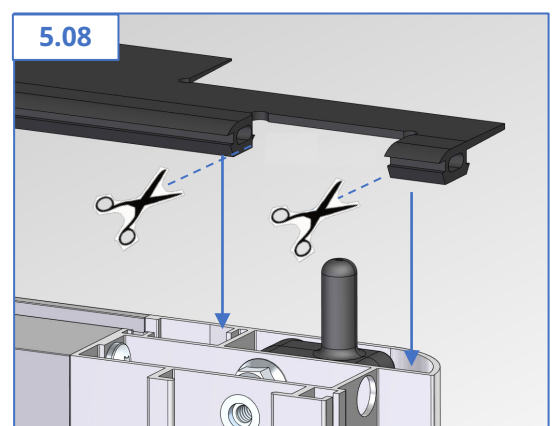
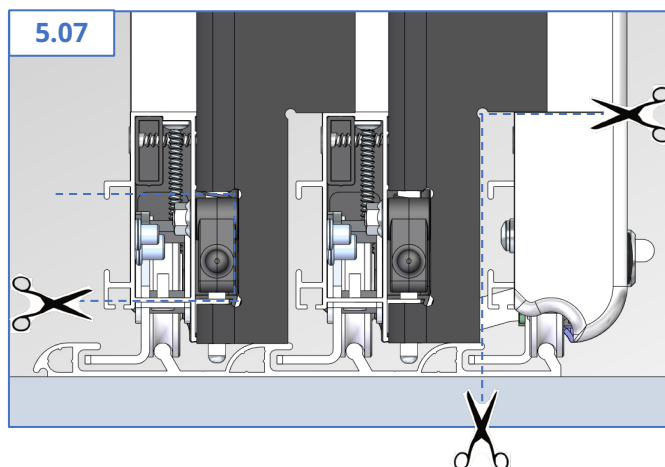
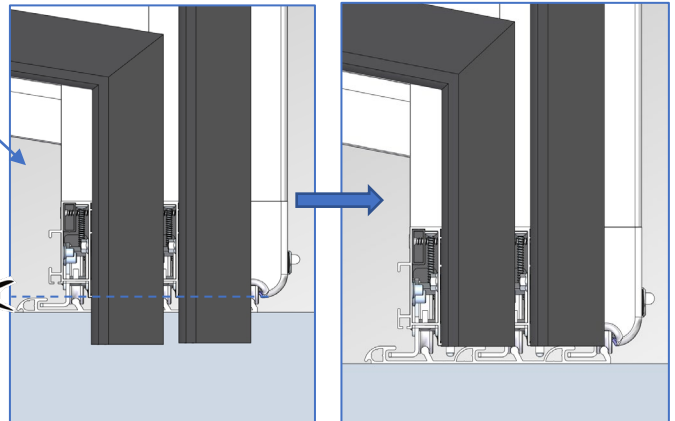
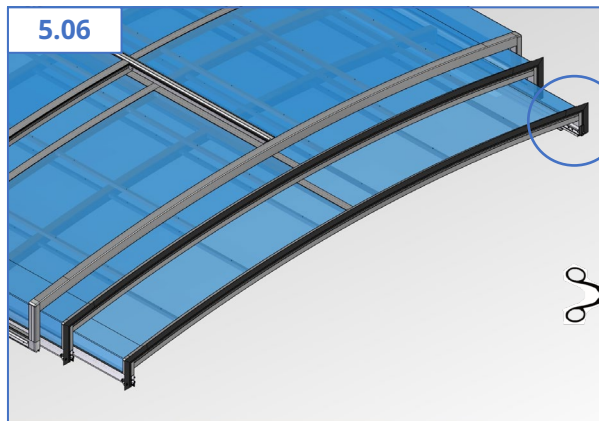
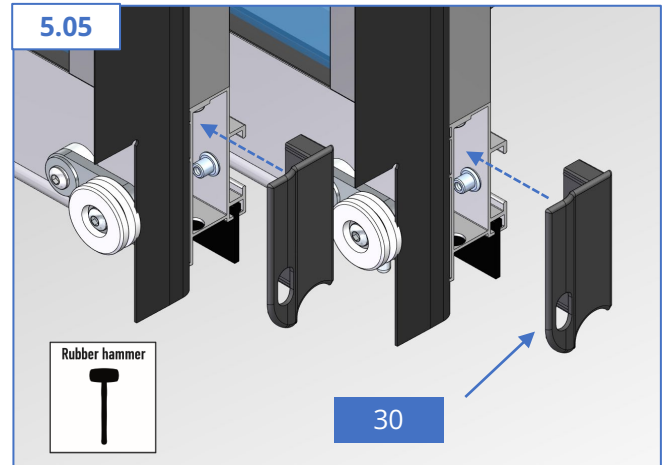
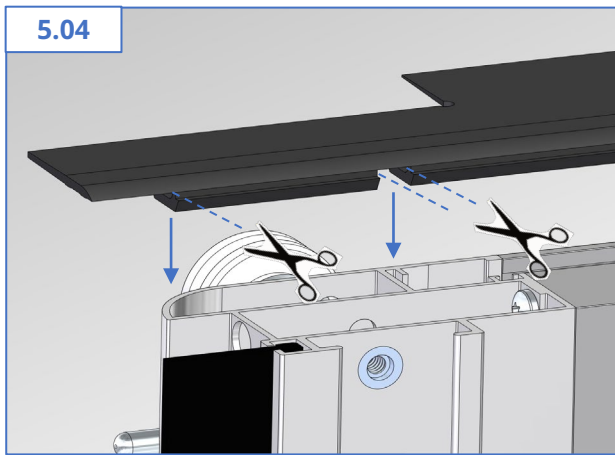

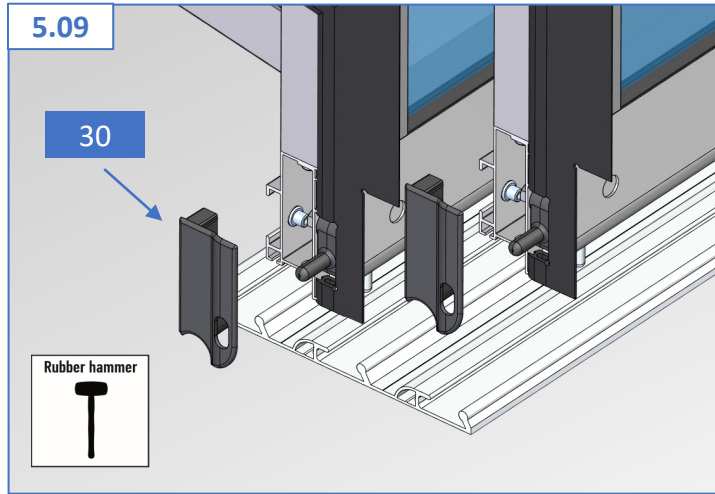

Låsbeslag (Nr.31.) ska inte monteras på minsta sektionen
TIPS!
 Se gärna vår låsfilm på hemsidan som förklarar funktionen.

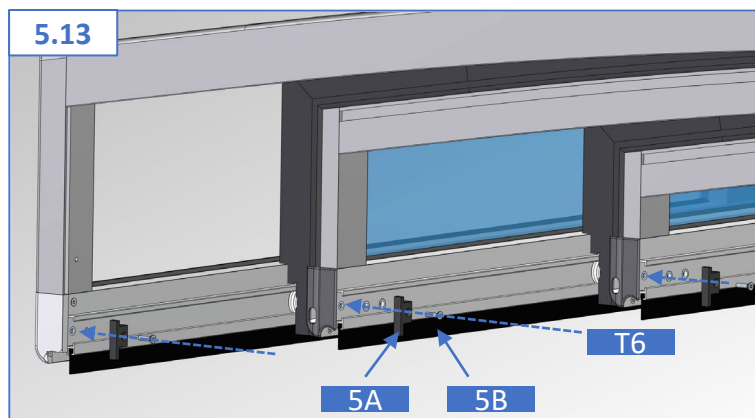
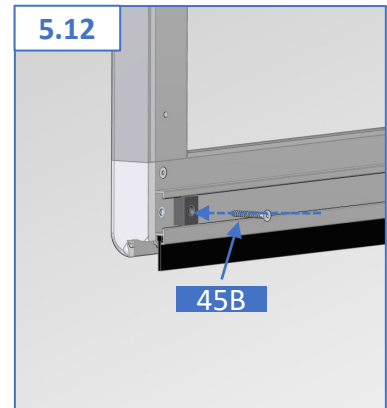
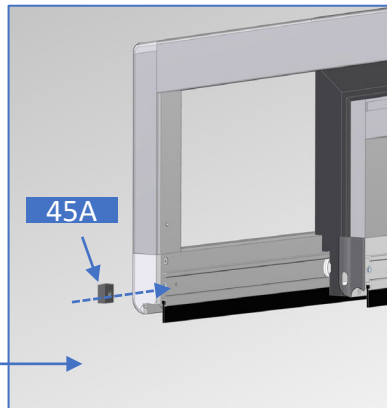
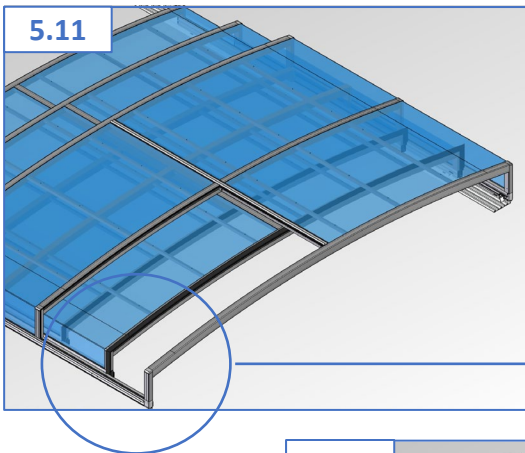
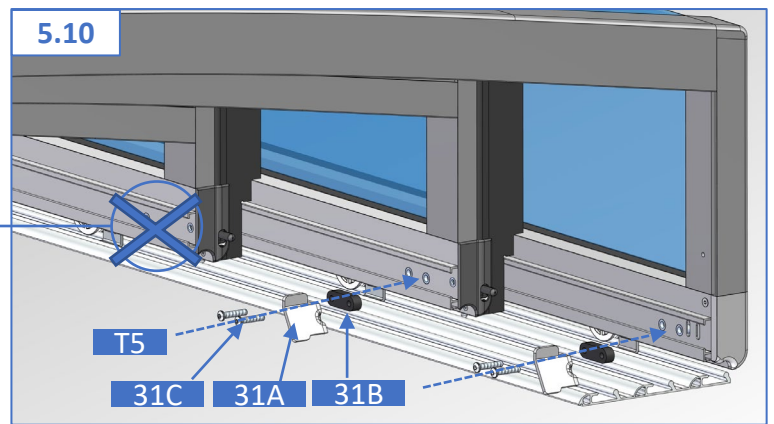

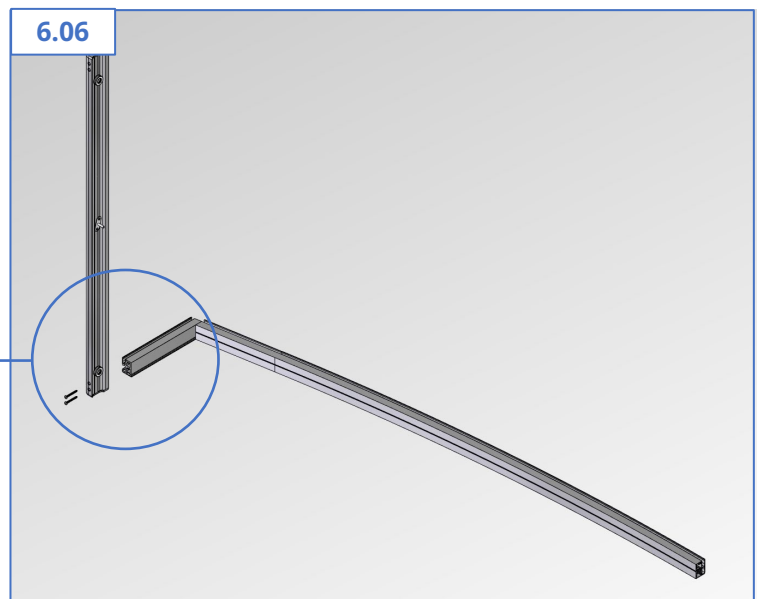
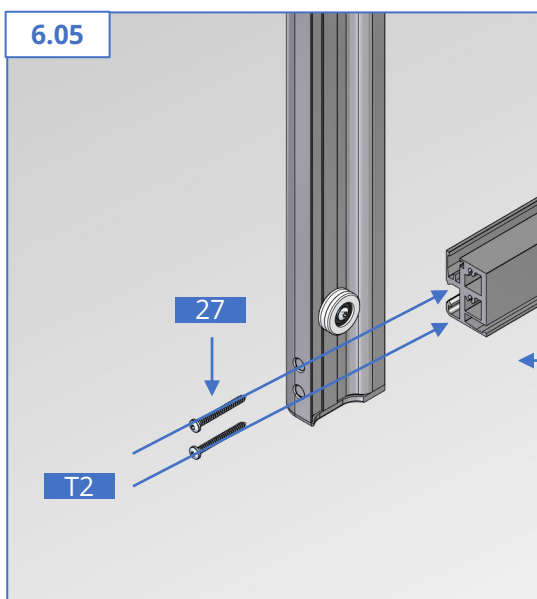
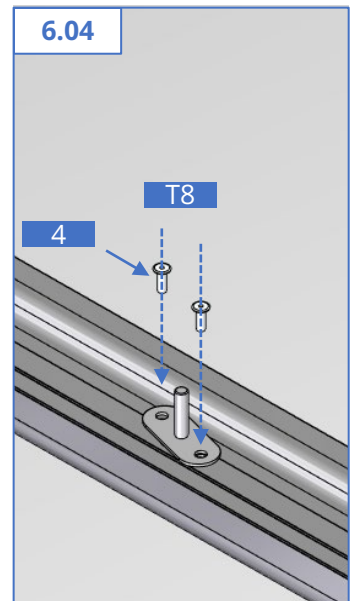
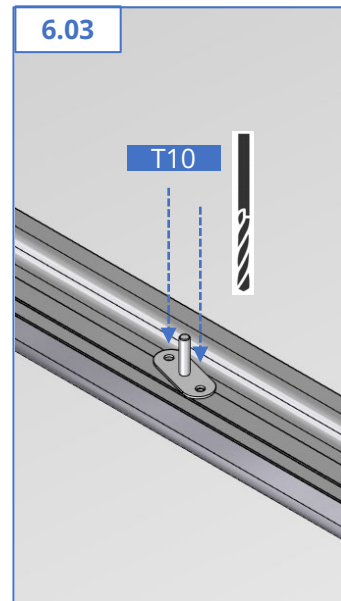
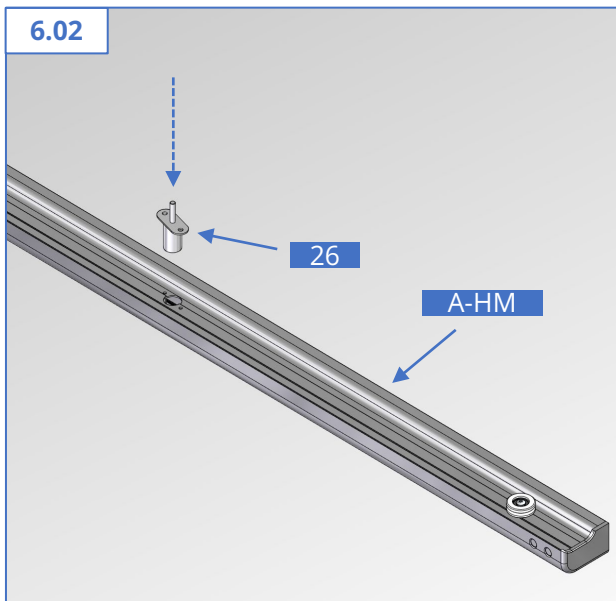
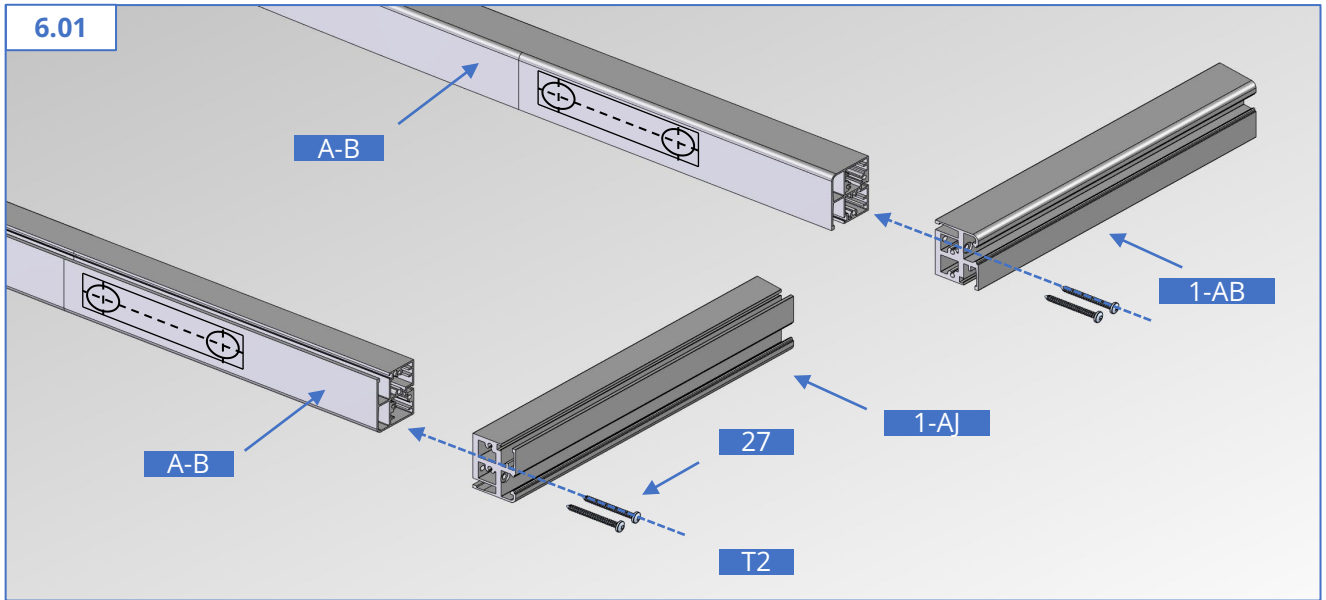

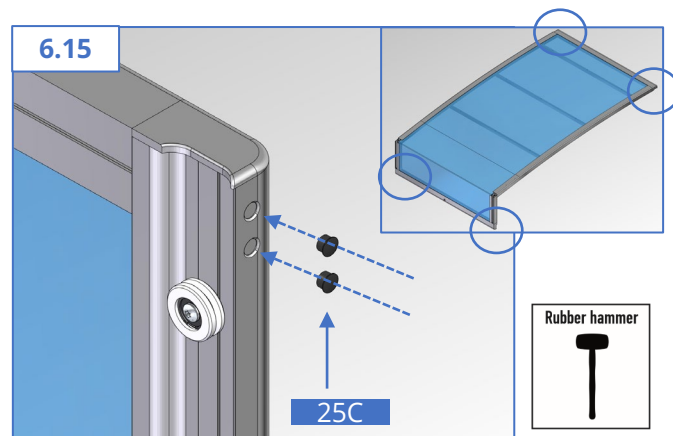
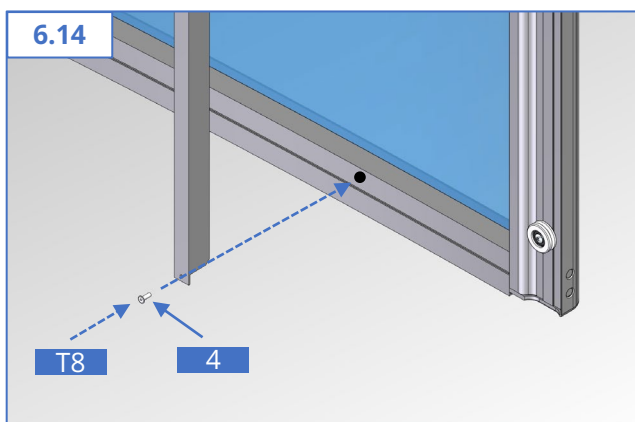
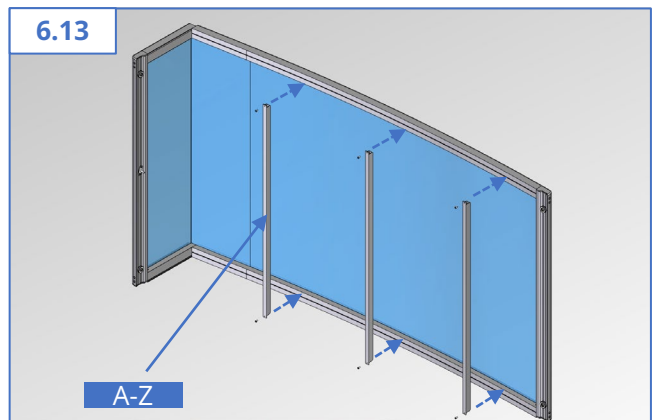
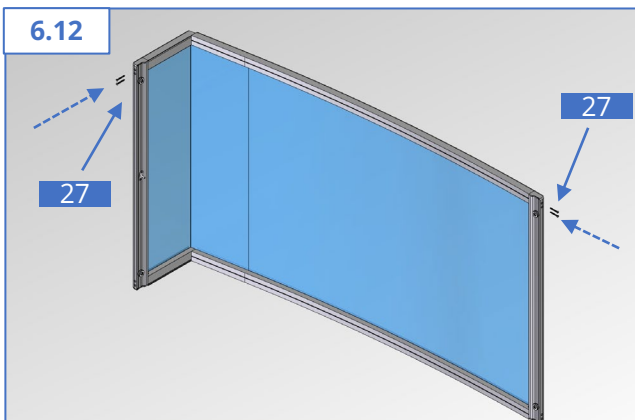
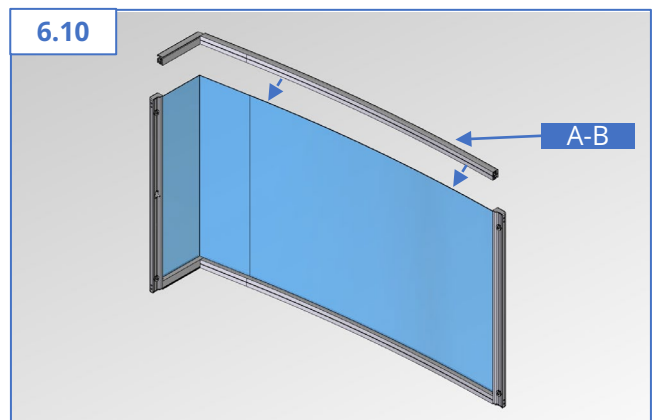
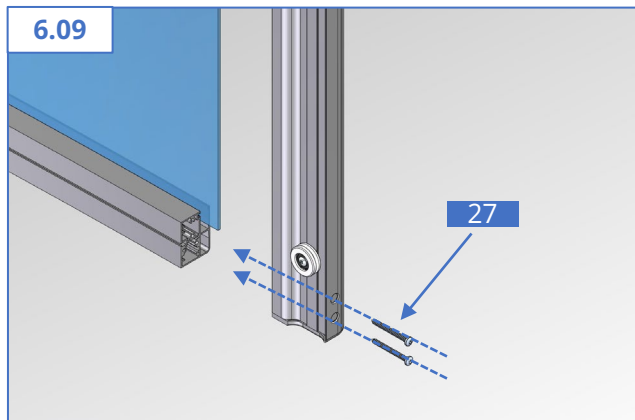
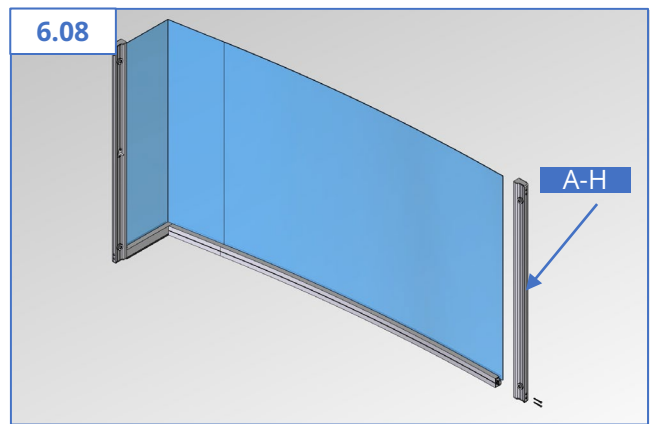
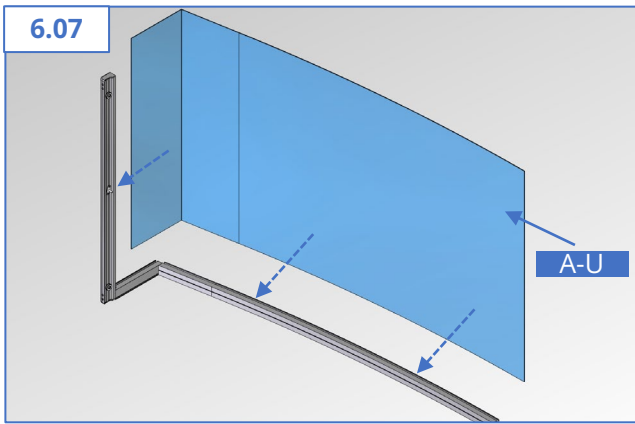

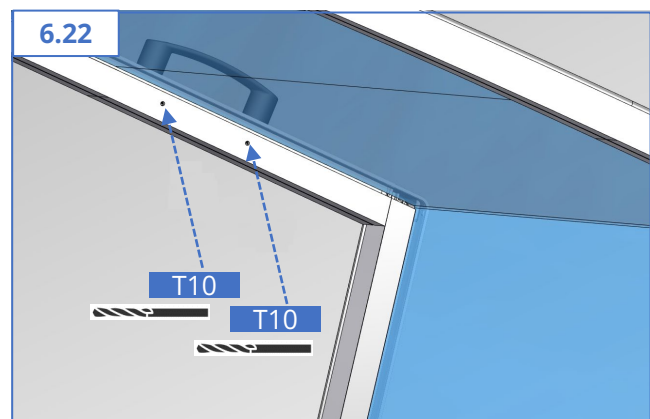
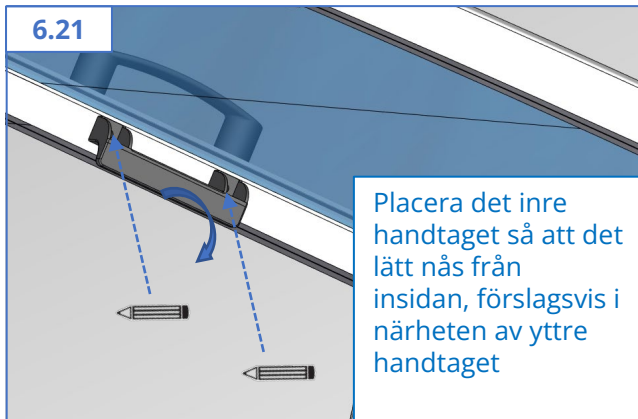
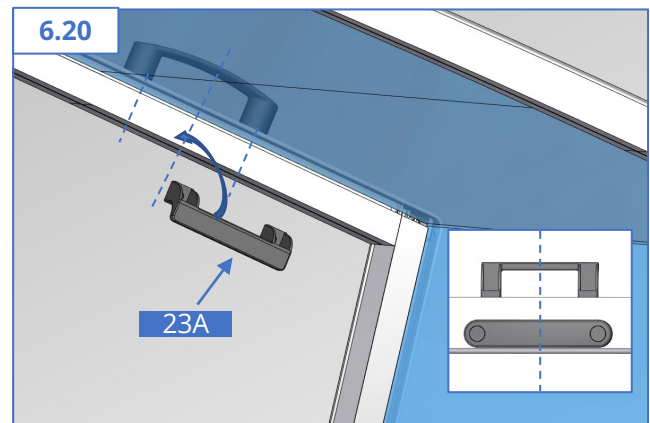
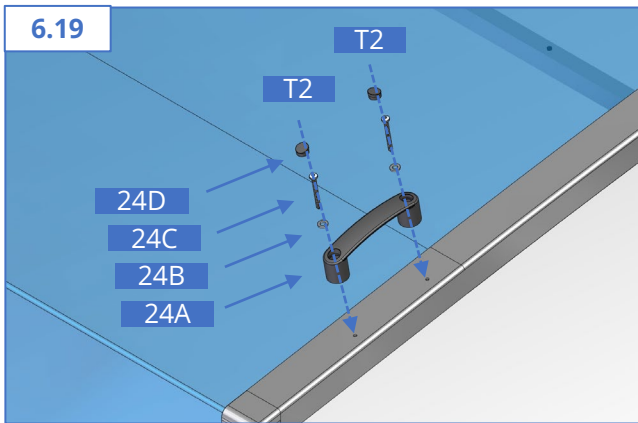
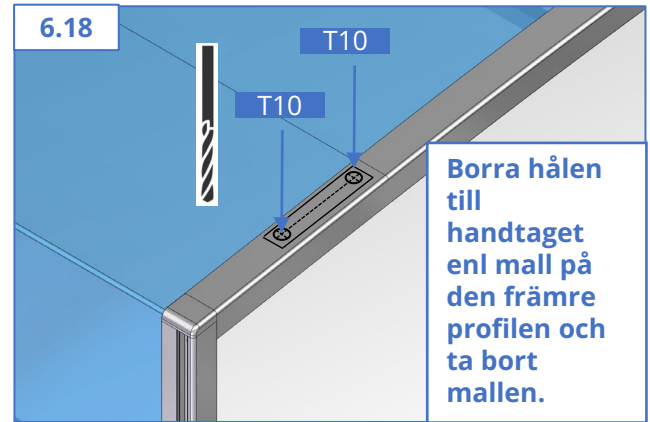
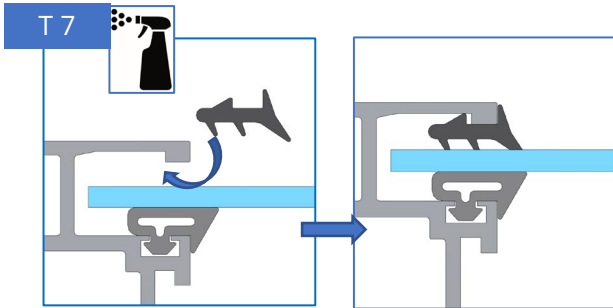
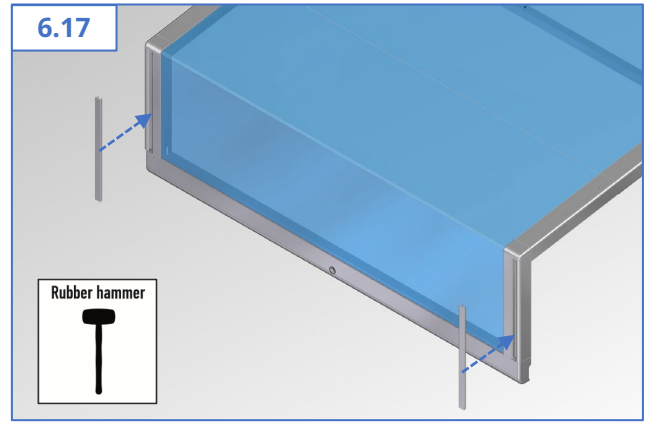
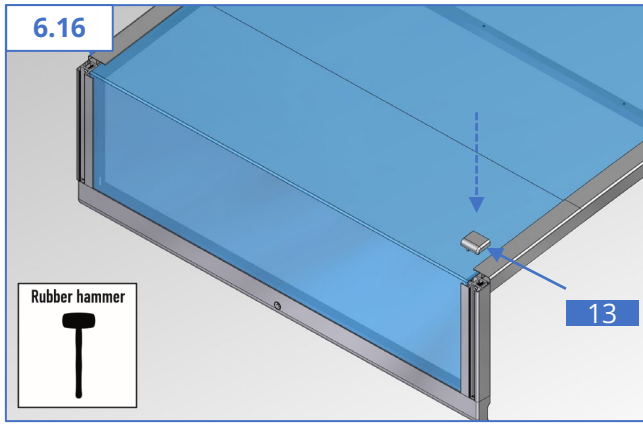

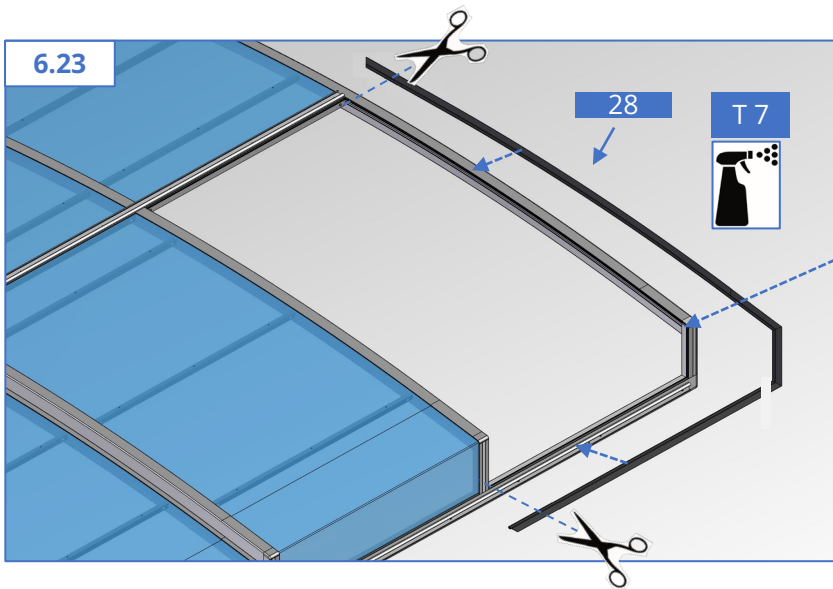

Vid montering av dörrlisten (nr 28) börja i hörnan med hörnändstycken (nr 13-14) klipp listen ca 10 mm längre och montera listen. OBS! Sträck inte listen.

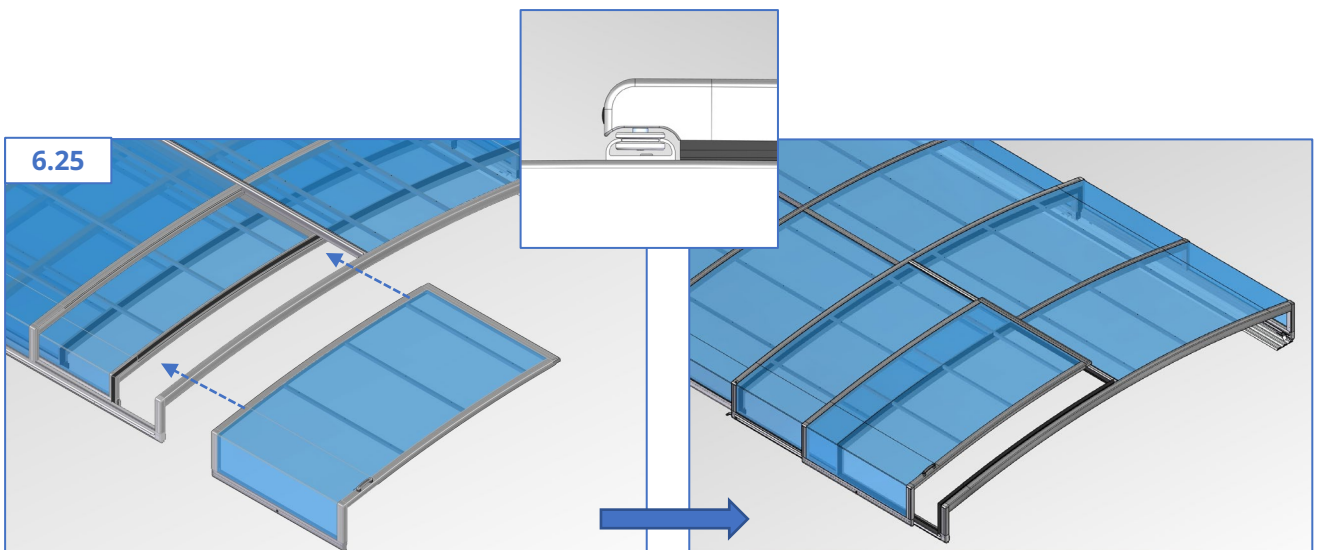
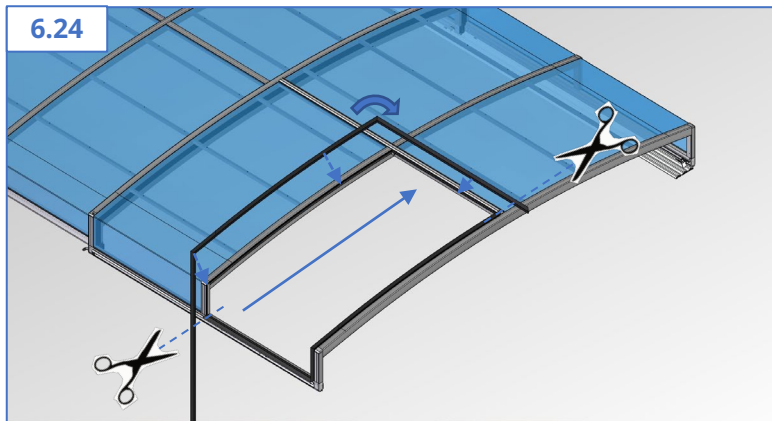
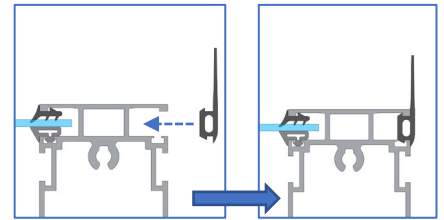

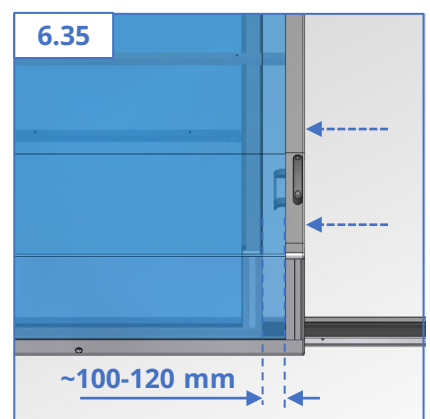
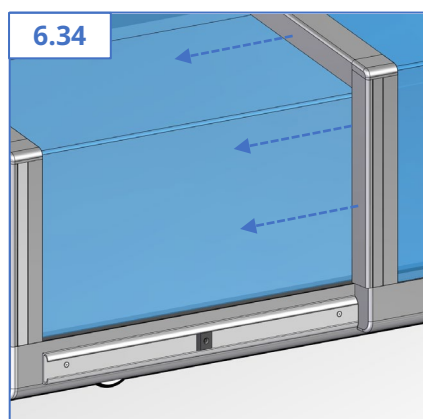
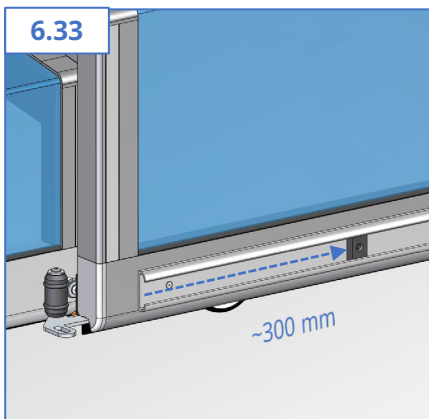
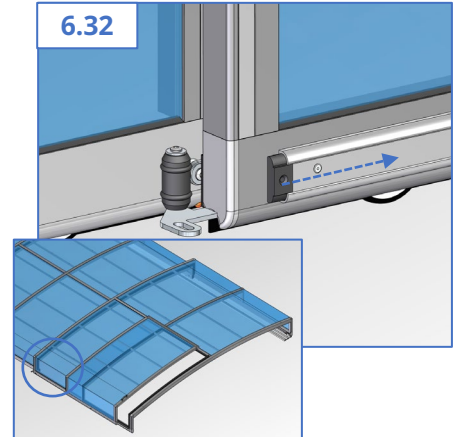
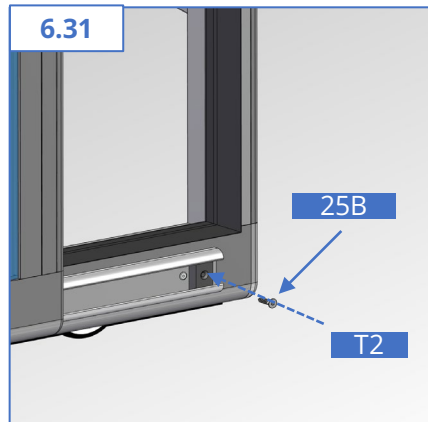
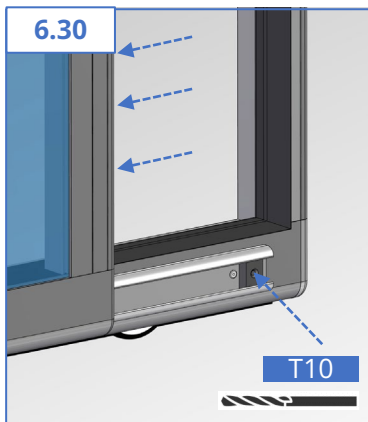
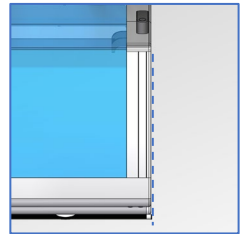
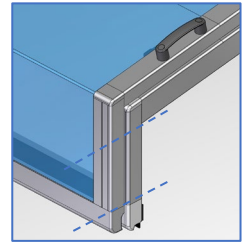
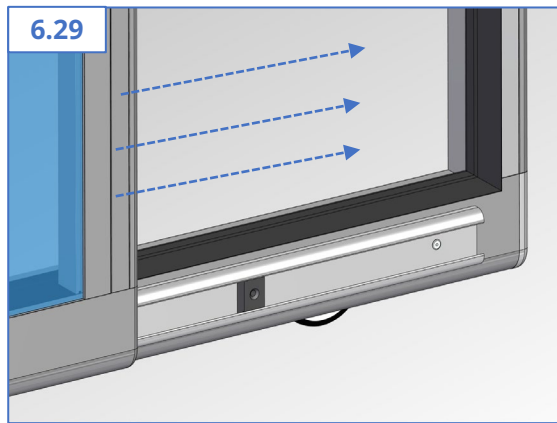
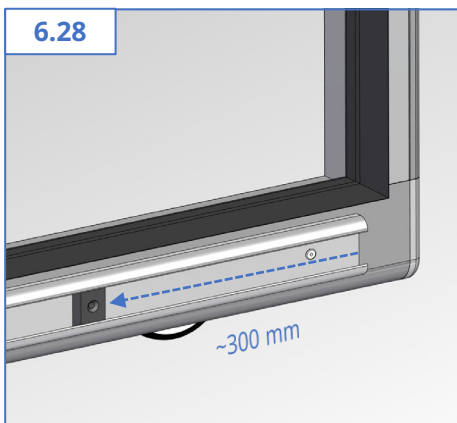
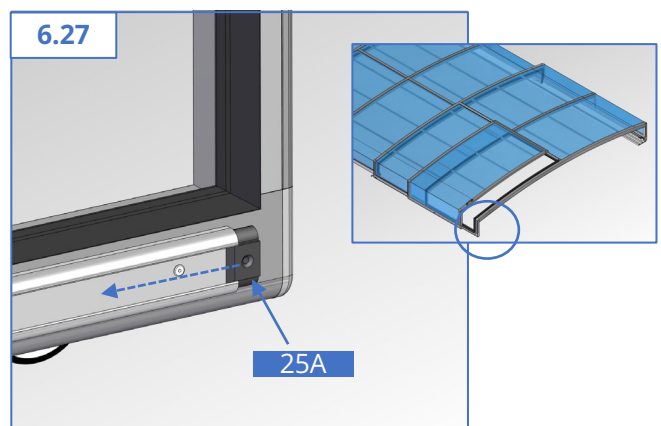
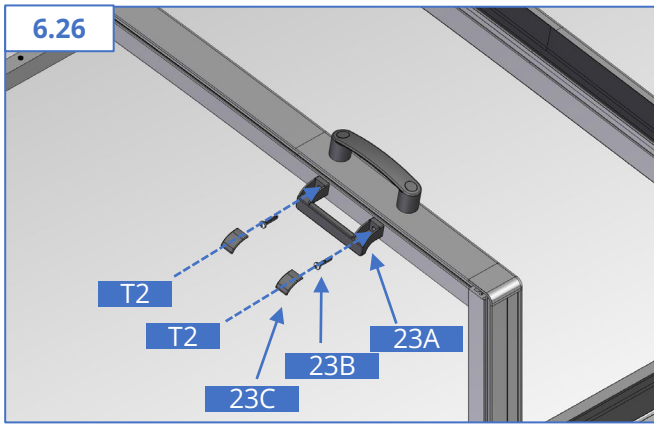

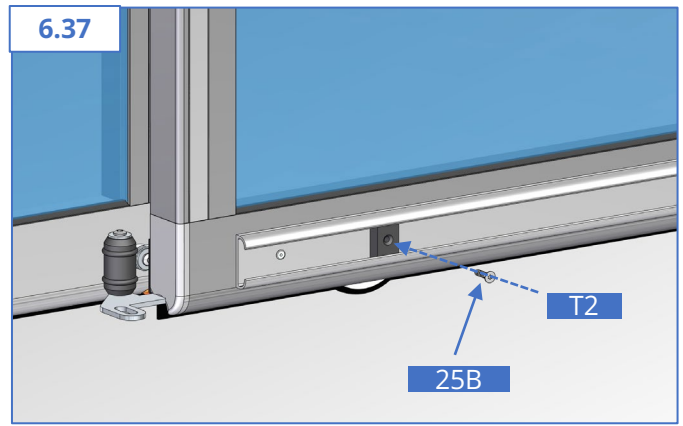
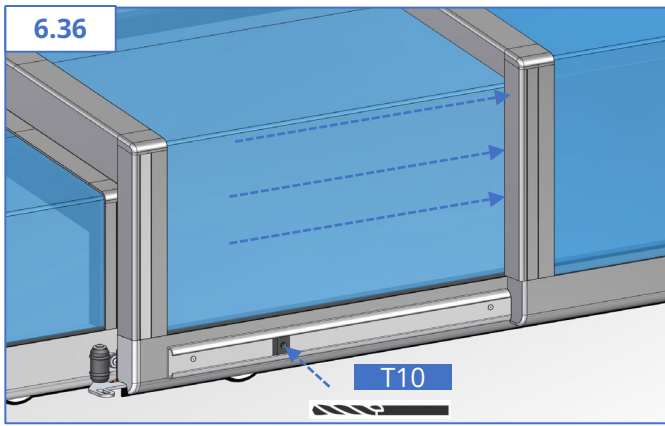

FRONTGAVEL:

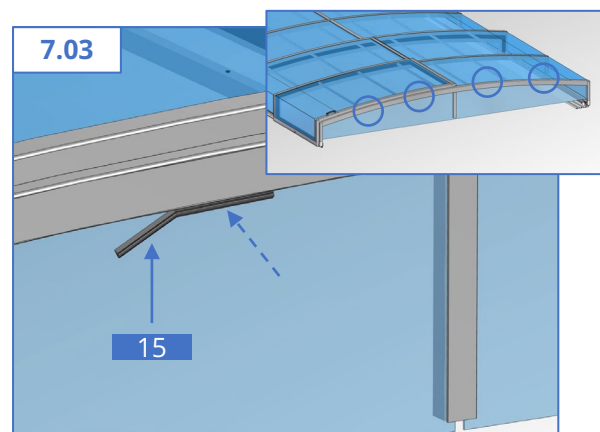
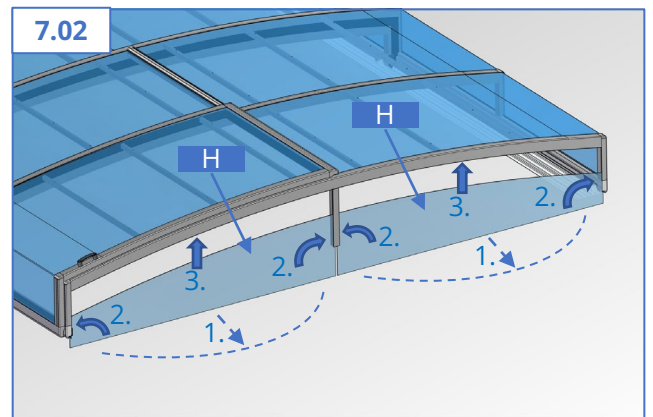
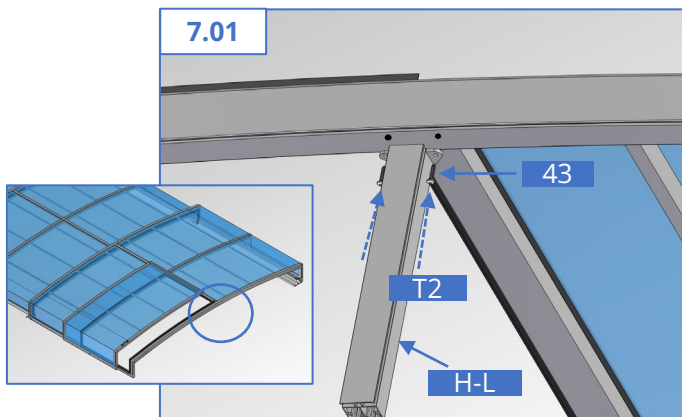

Fixera panelerna temporärt med en bit gummlist (ca 20cm) tills bottenprofilen är monterad

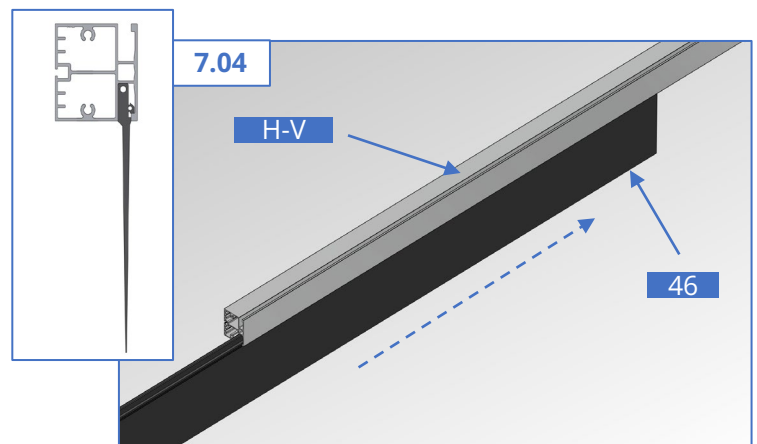



7.05



OBS! Listen krymper lite i början, listen kan med fördel vara lite "vågig" vid montering. Klipp ca 5cm extra lång vid varje sida.

7.06

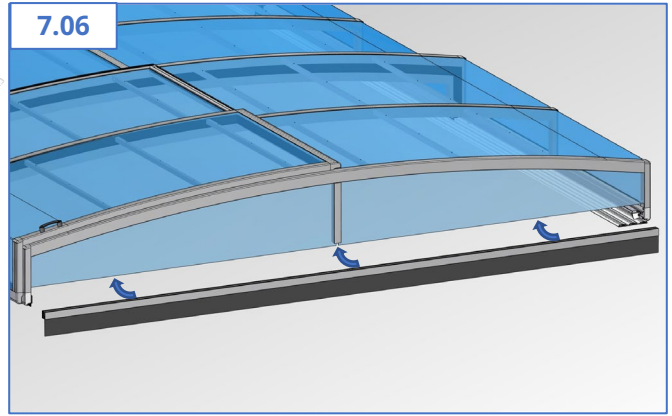

7.07

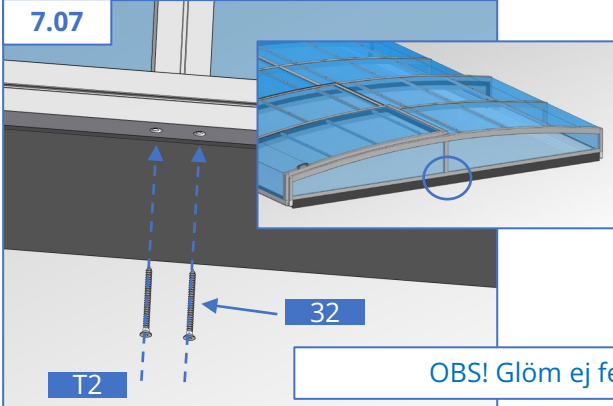

7.08

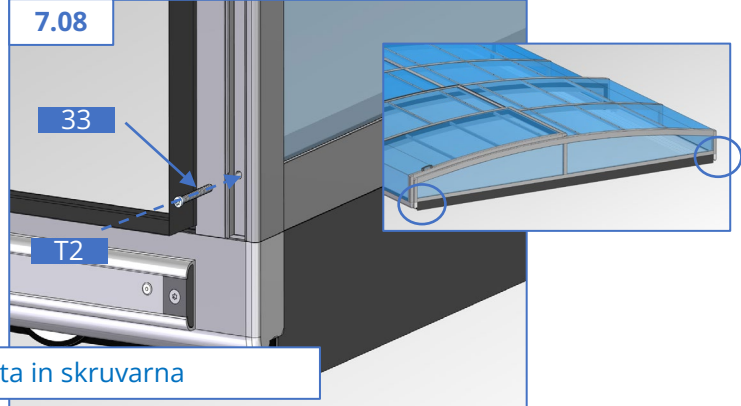

OBS! Glöm ej fetta in skruvarna

7.09

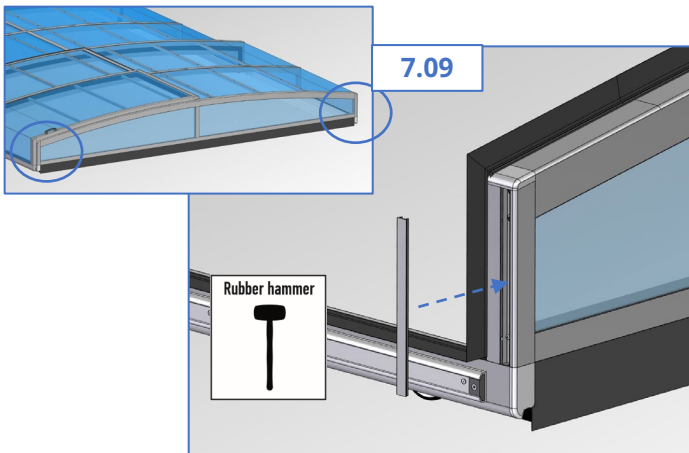

7.10

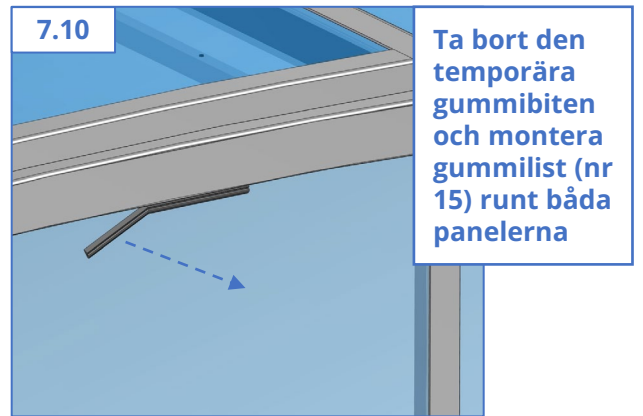

Ta bort den temporära gummibiten och montera gummilist (nr 15) runt båda panelerna

BAKGAVEL:

7.11

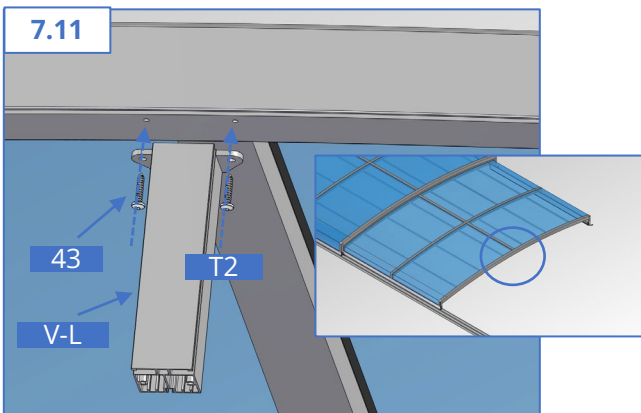

7.12

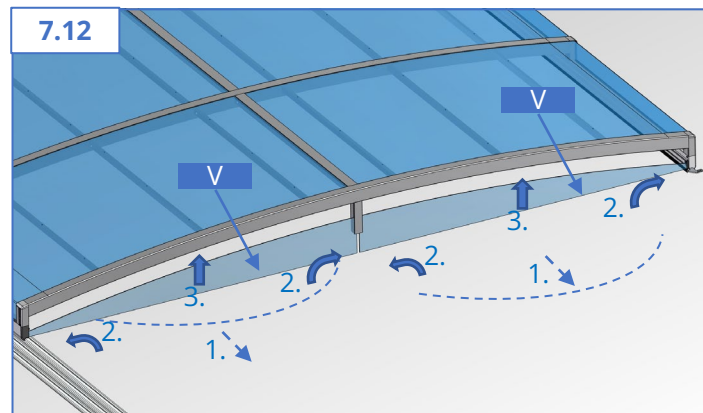

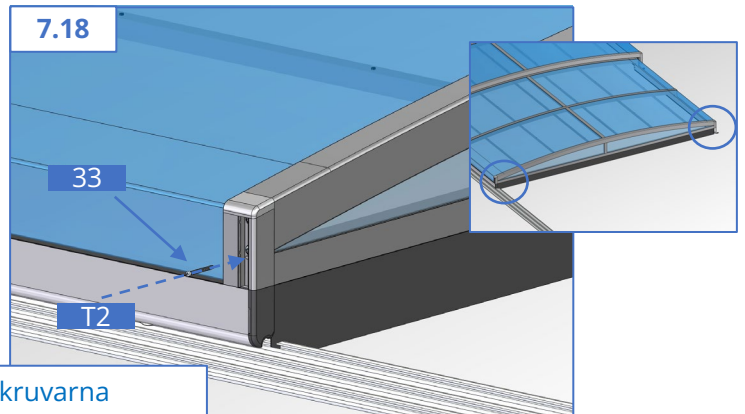
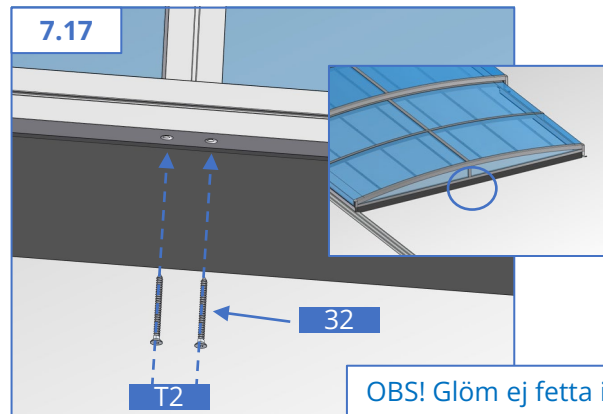
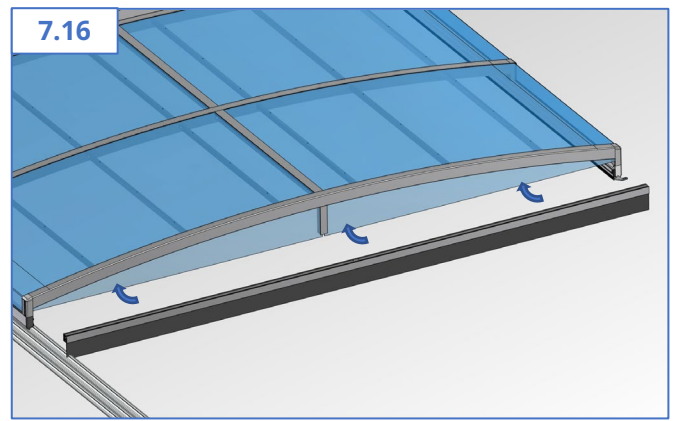
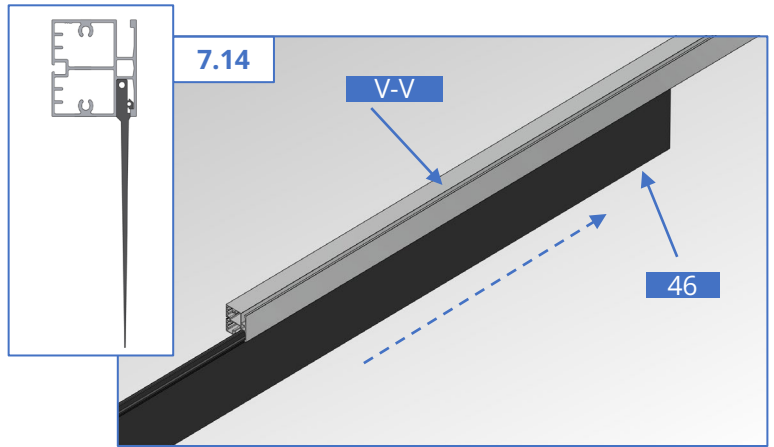
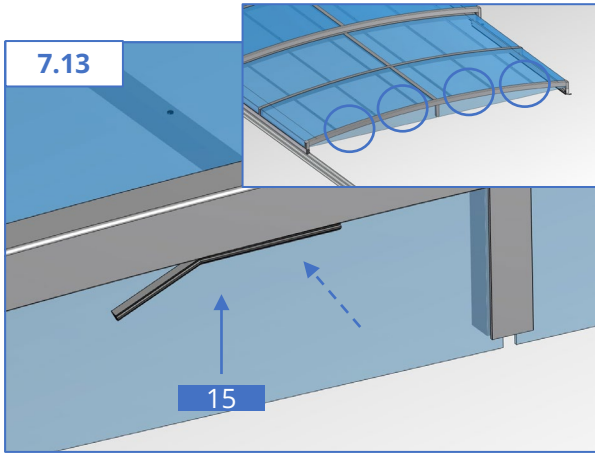

OBS! Glöm ej fetta in skruvarna

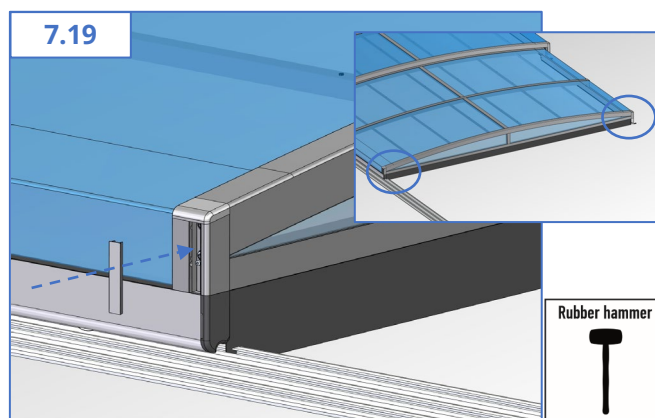

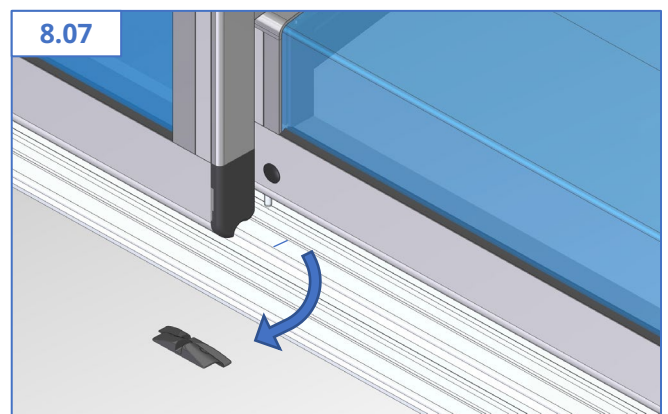
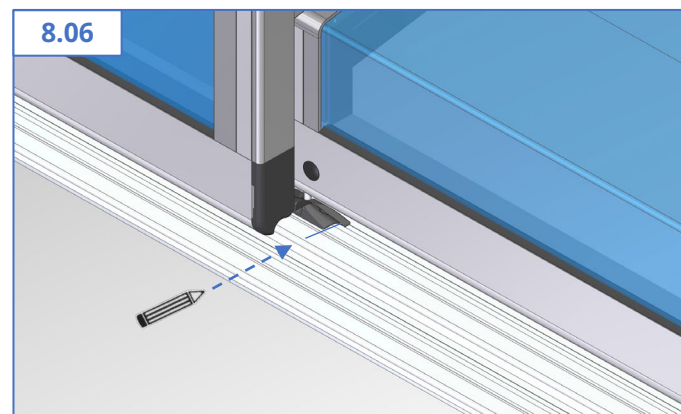
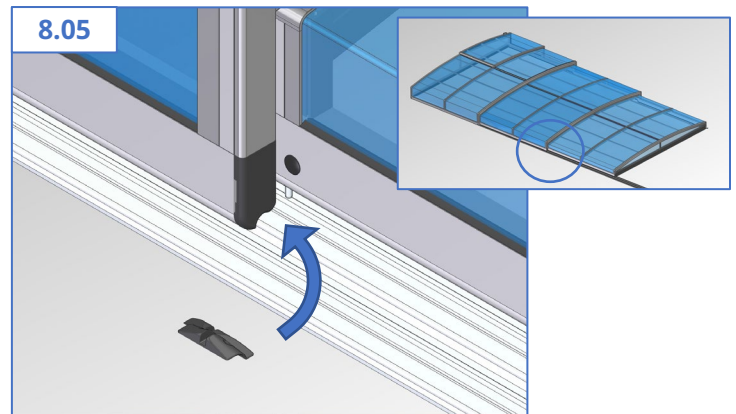
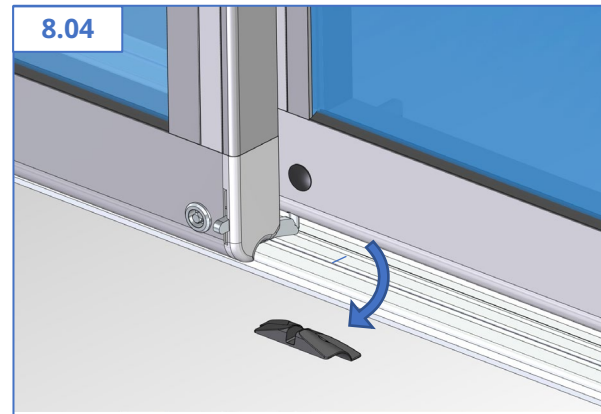
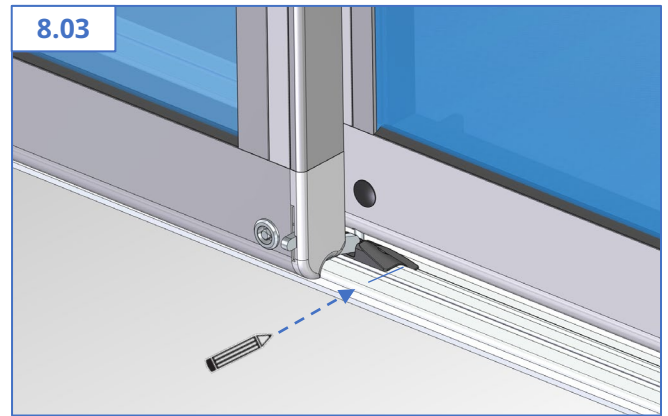
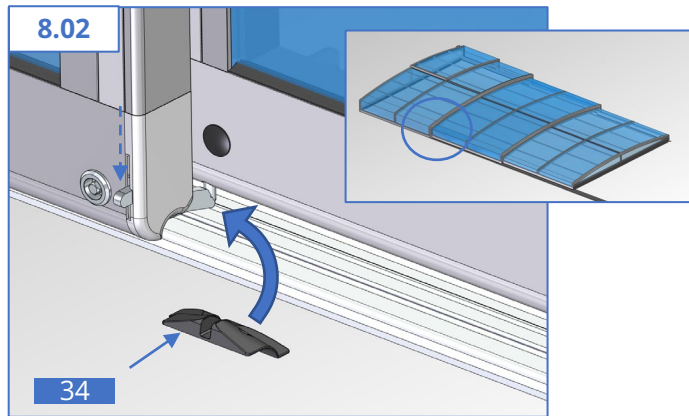
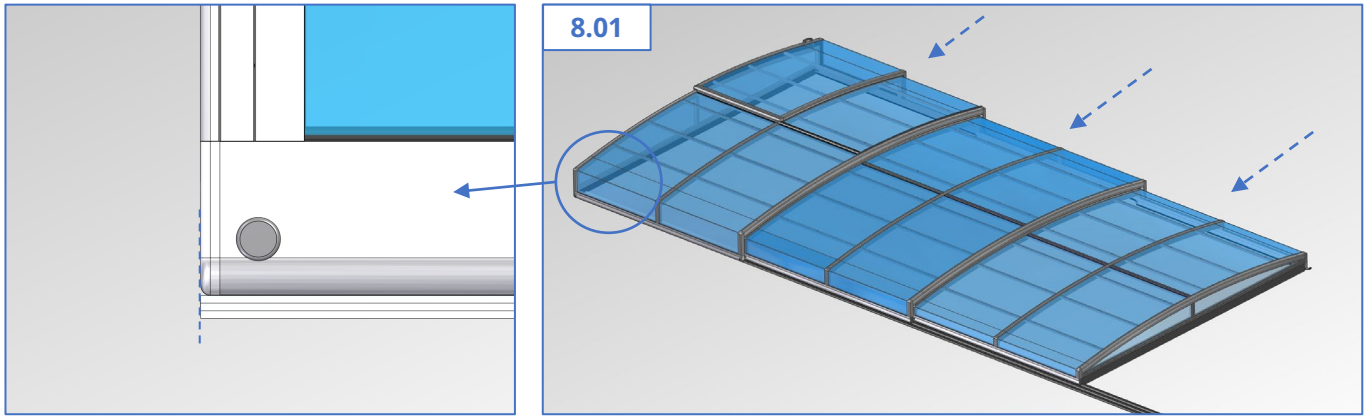

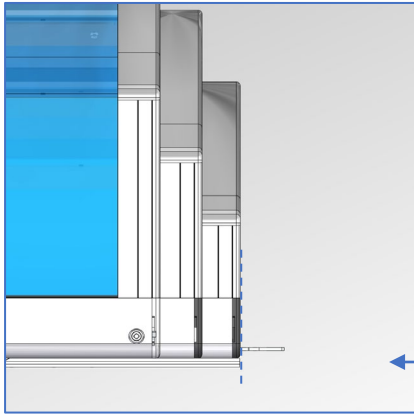

8.08

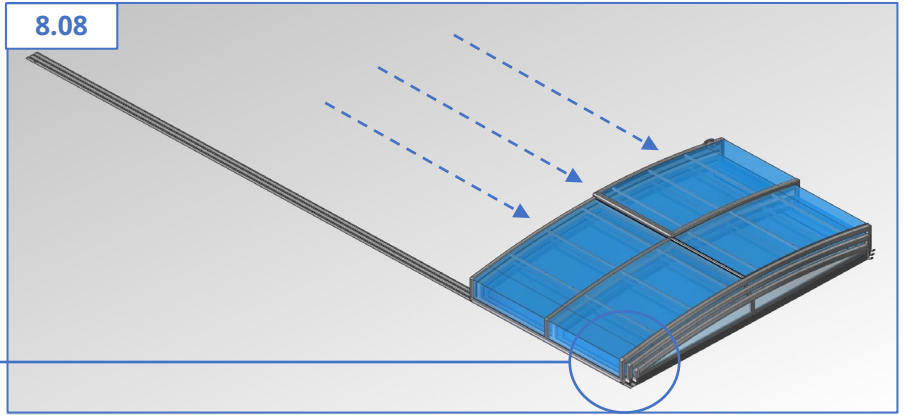

8.09

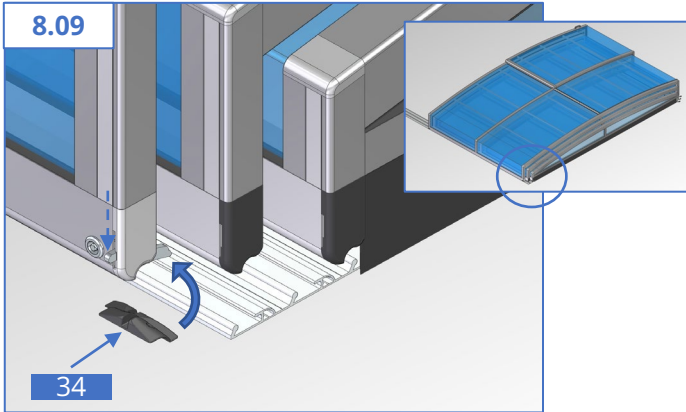

8.10

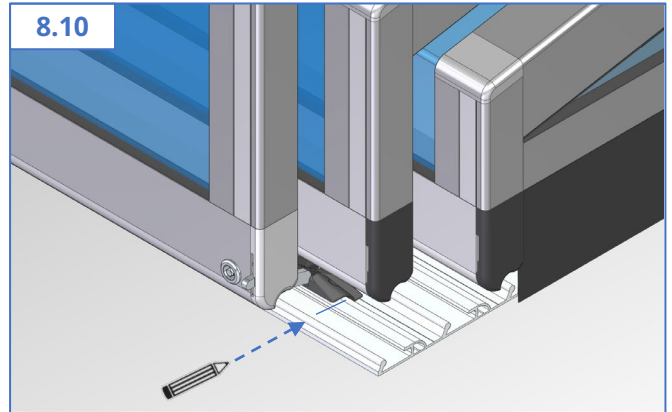

8.11

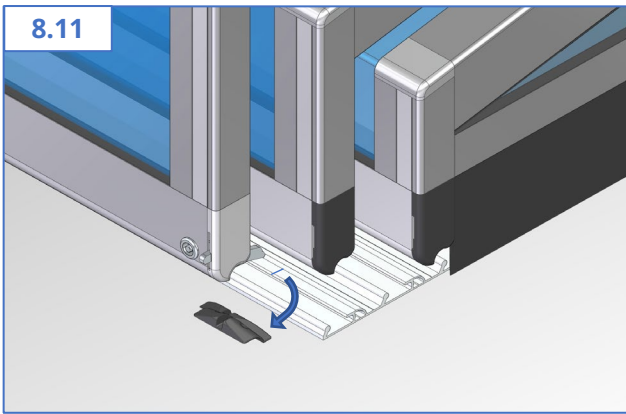

8.12

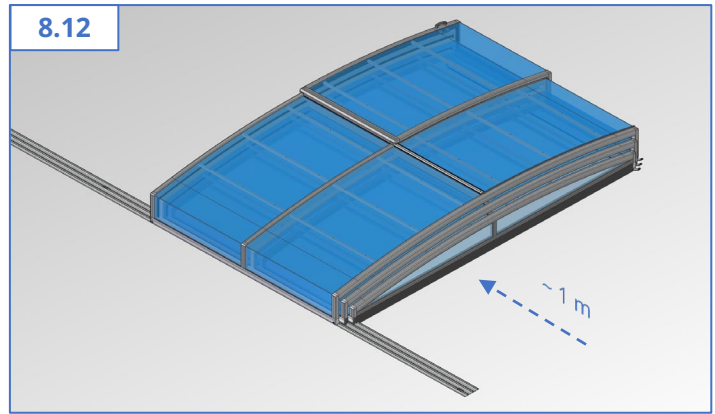

8.13

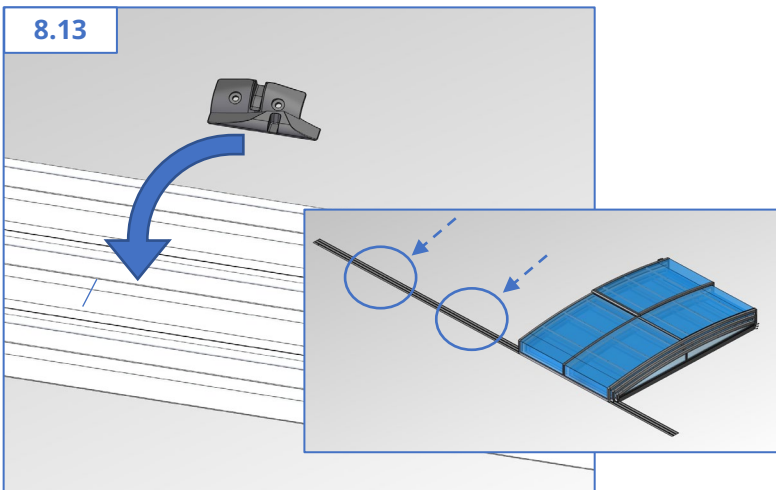

8.14

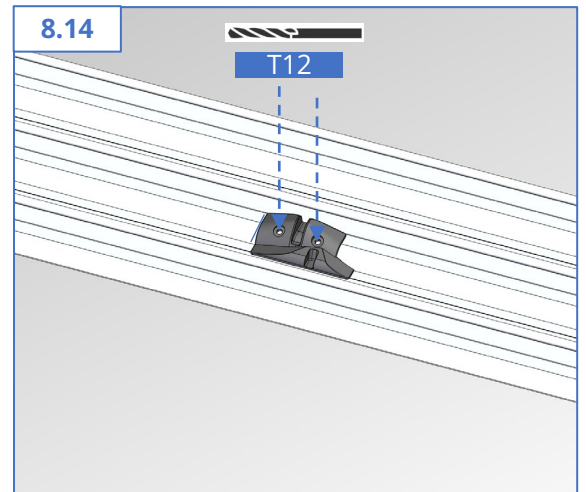

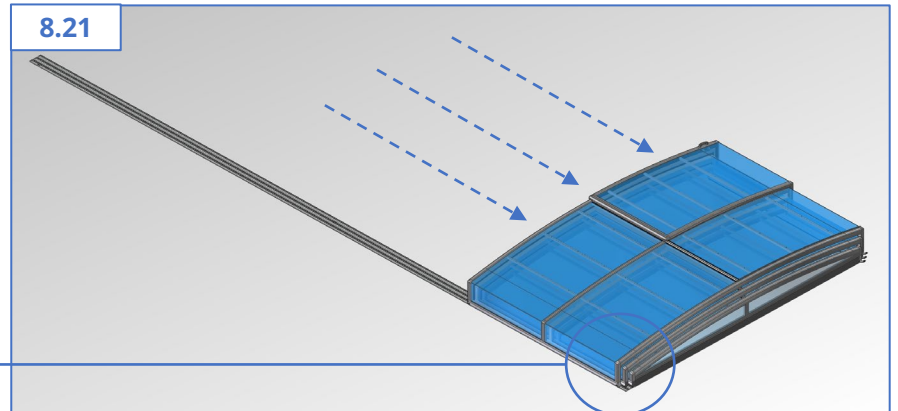
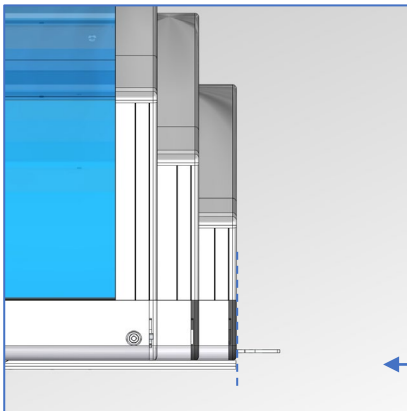
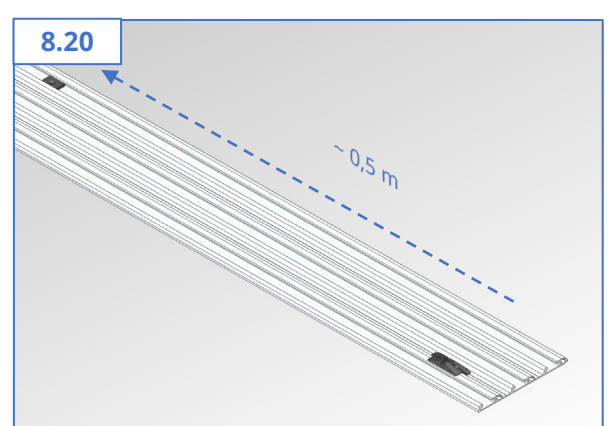
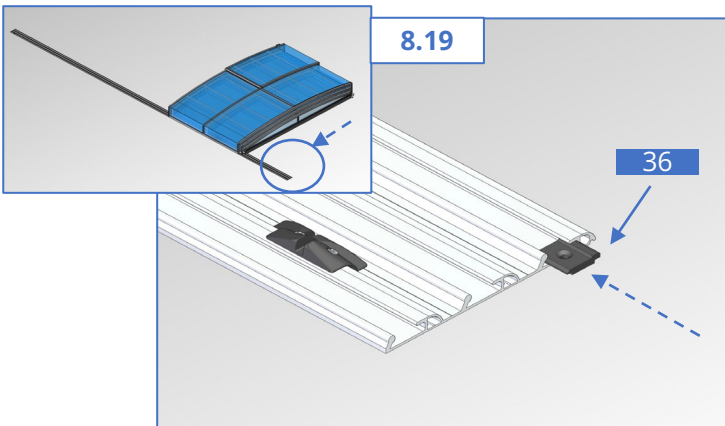
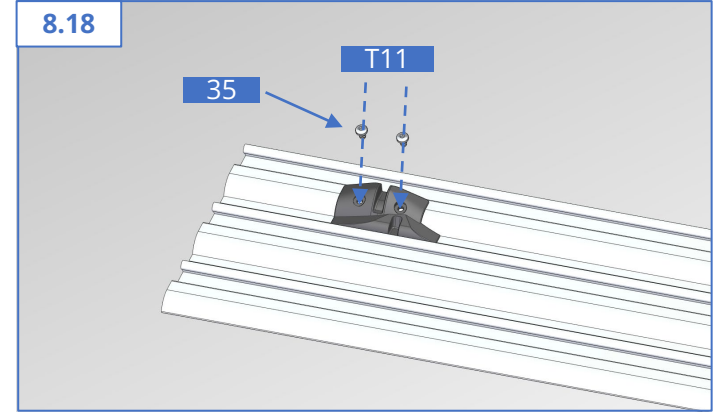
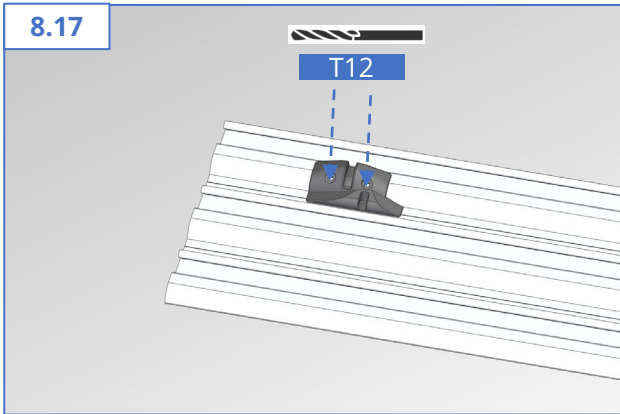
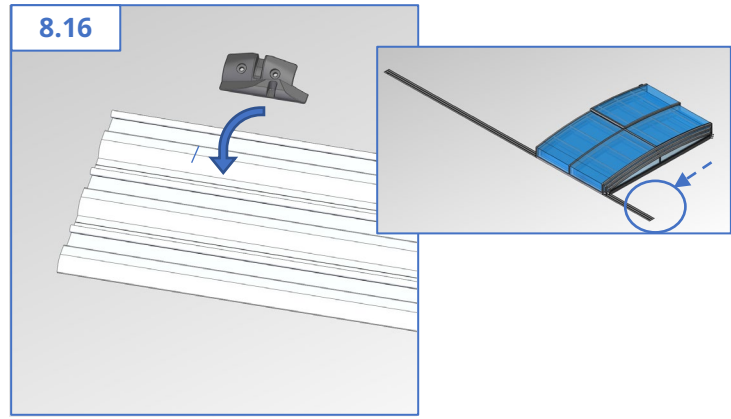
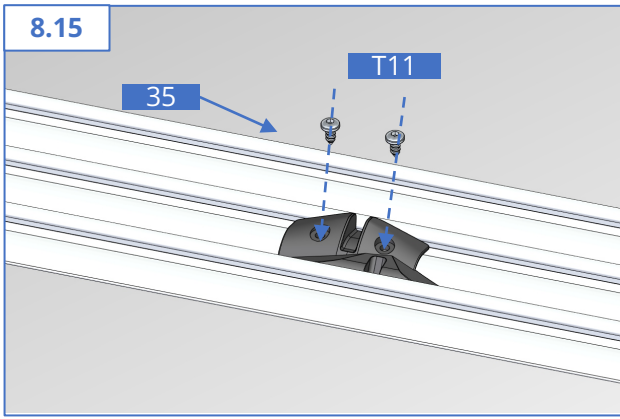

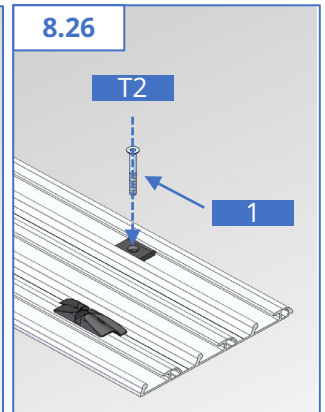
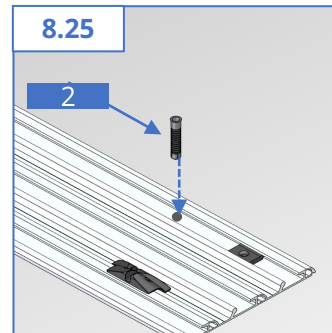
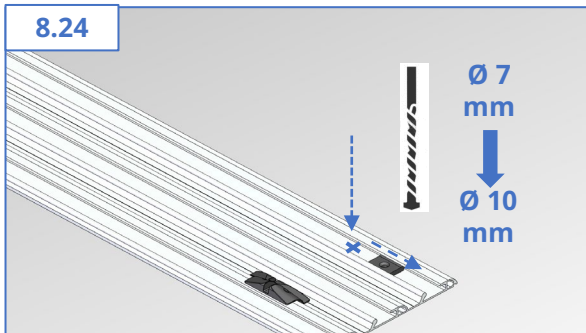
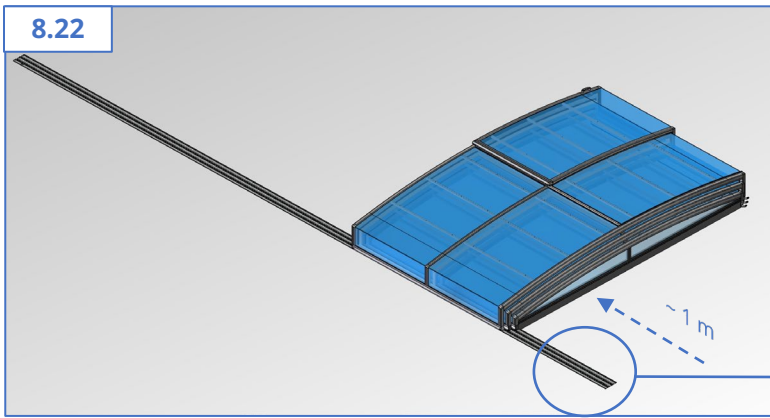

På hårt underlag (ej trä) ska hålen borraras med 7 mm borrh och sen 10 mm borrh under skenan och minst ett djup på 60 mm

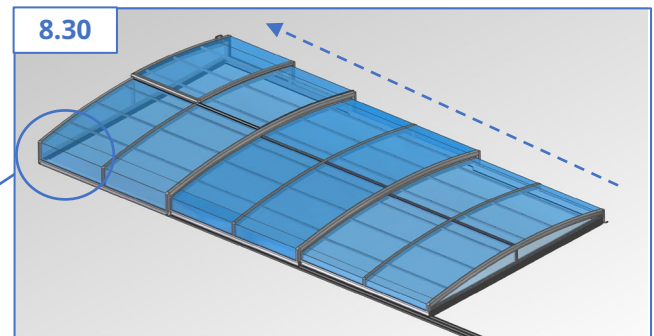
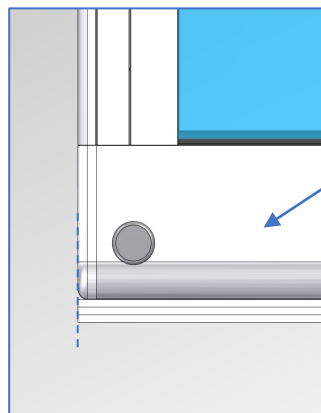
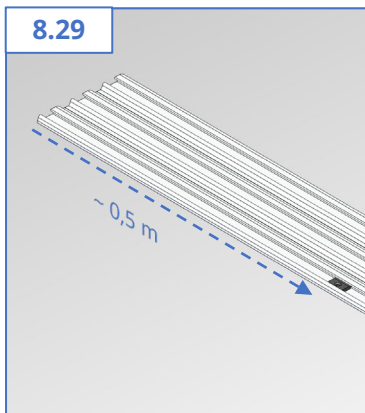
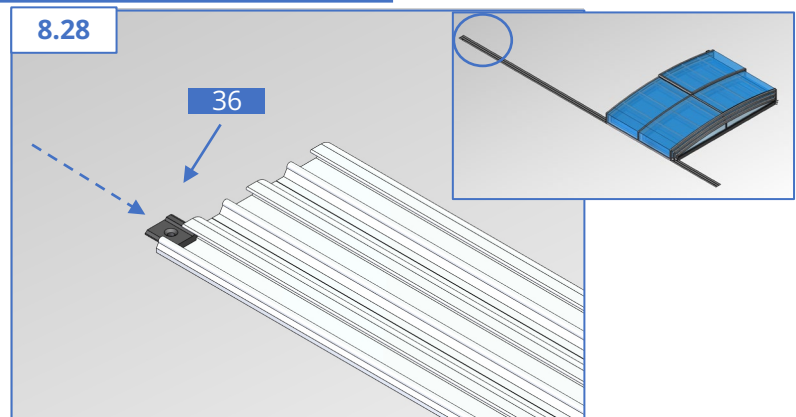
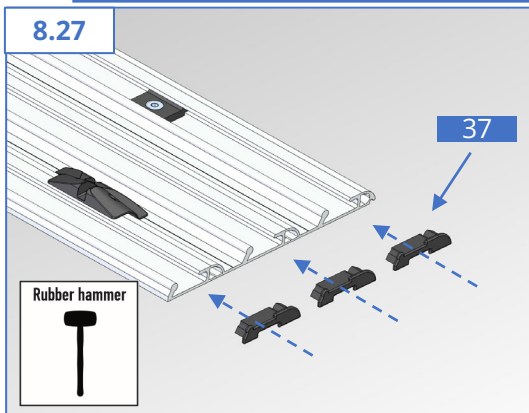



8.31

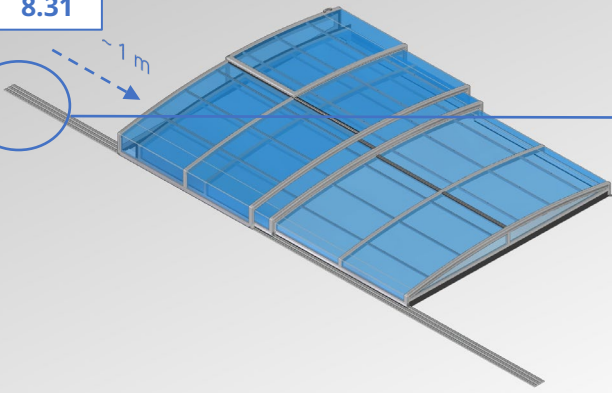

8.32

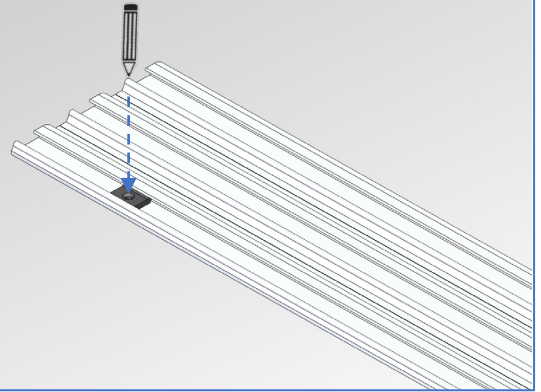

8.33

Ø 7 mm
↓
Ø 10 mm

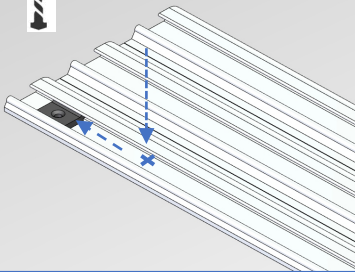

8.34

2

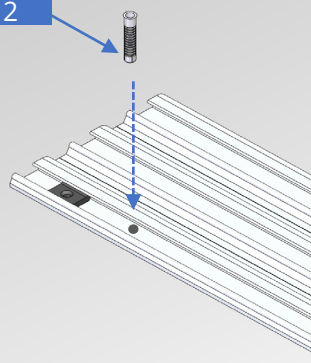

8.35

1

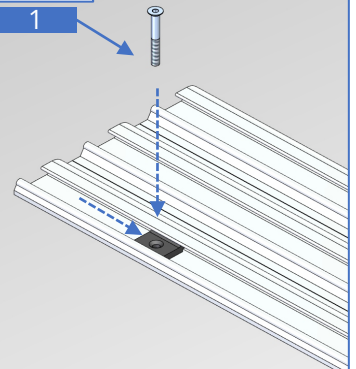

8.36

37

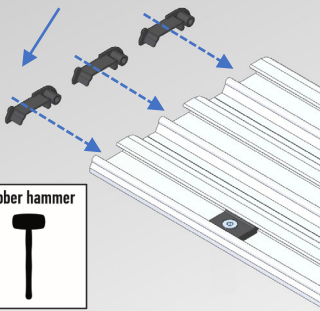

8.37

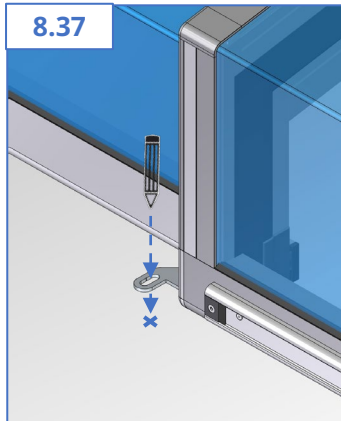

8.38

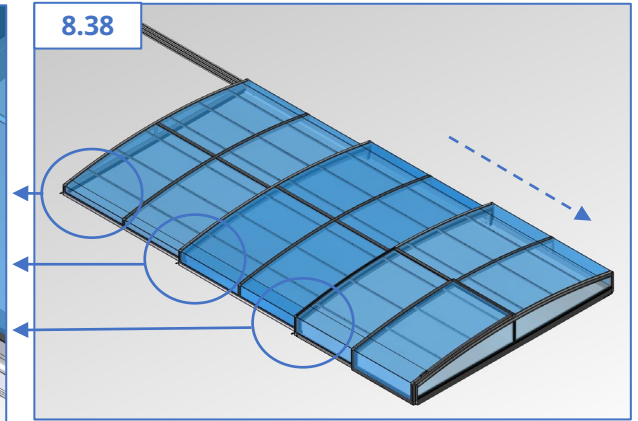

8.39

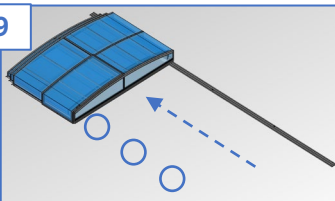

Montering på
hårt
underlag

Ø 10 mm
↓
60 mm

47

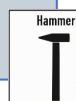
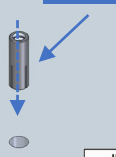

Montering
på trä.

38

40

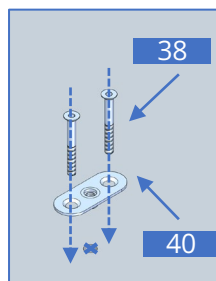

8.40

