

Assembly Instruction and Care Advice

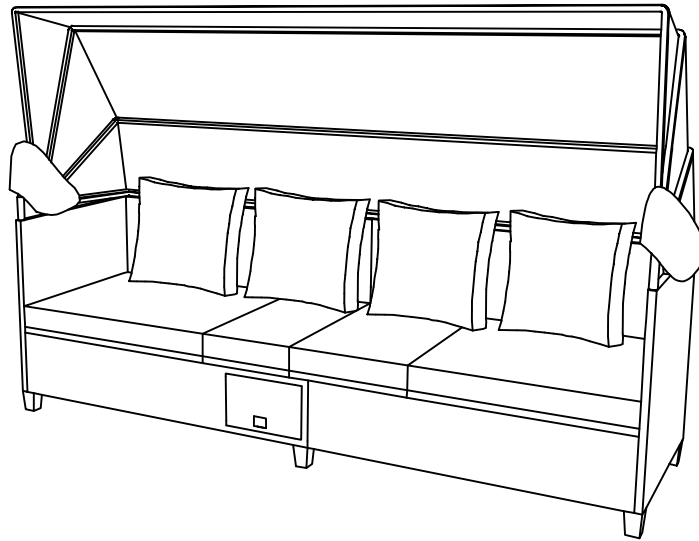

Description: Nopy Sun Lounge
Article number: 2067-222

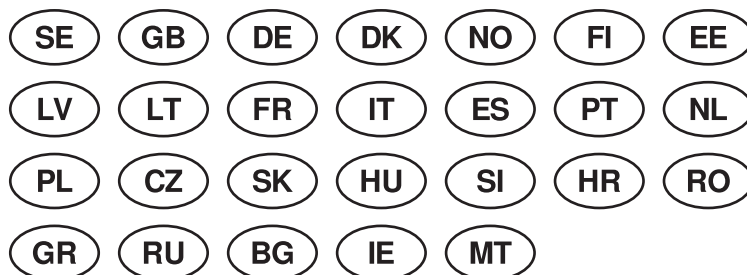

Thank you for purchasing this Venture Home product!

**Venture
home**



www.venturehome.se
www.venturedesign.se







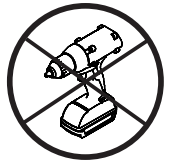
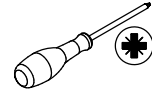





@venturehomese
@venture.design

Assembly Instruction





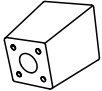

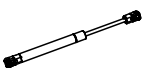
Hardware List

SP - 18905-000 - Screw Set

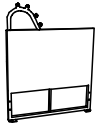
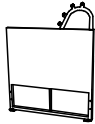
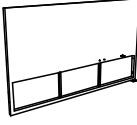
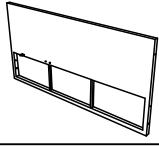
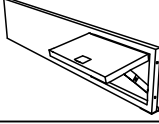
No.	DESCRIPTION	QTY.
A	M6*20 	14pcs
B	M6*25 	8pcs
C	M6*40 	26pcs
D	M6*55 	6pcs
E	Ø6*14*1 	33pcs
F	Ø6*16*3 	4pcs
G	Ø6*16*5 	8pcs
H	M6 	8pcs
J	M4*12 	12pcs
K	45*45*65 	6pcs
L	40 	2pcs
M	120N 	2pcs

Part List

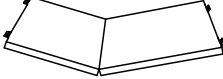
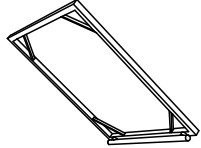
No.	DESCRIPTION	QTY.
1		1pc
2		1pc
3		1pc
4		1pc
5		1pc
6		1pc
7		2pcs
8		2pcs
9		2pcs
10		1pc
11		1pc

Assembly Instruction

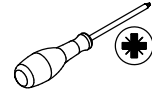

Part List

No.	DESCRIPTION	QTY.			
12		1pc	A1		1pc
13		1pc	A2		1pc
14		1pc	A3		1pc
15		1pc	A4		1pc
16		1pc	B1		1pc
17		4pcs	B2		1pc
			B3		1pc
			B4		1pc
			C1		1pc
			C2		1pc
			C3		1pc
			C4		1pc
			D1		1pc
			D2		1pc
			D3		1pc
			D4		1pc

Assembly Instruction

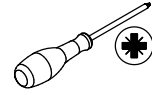

Part List

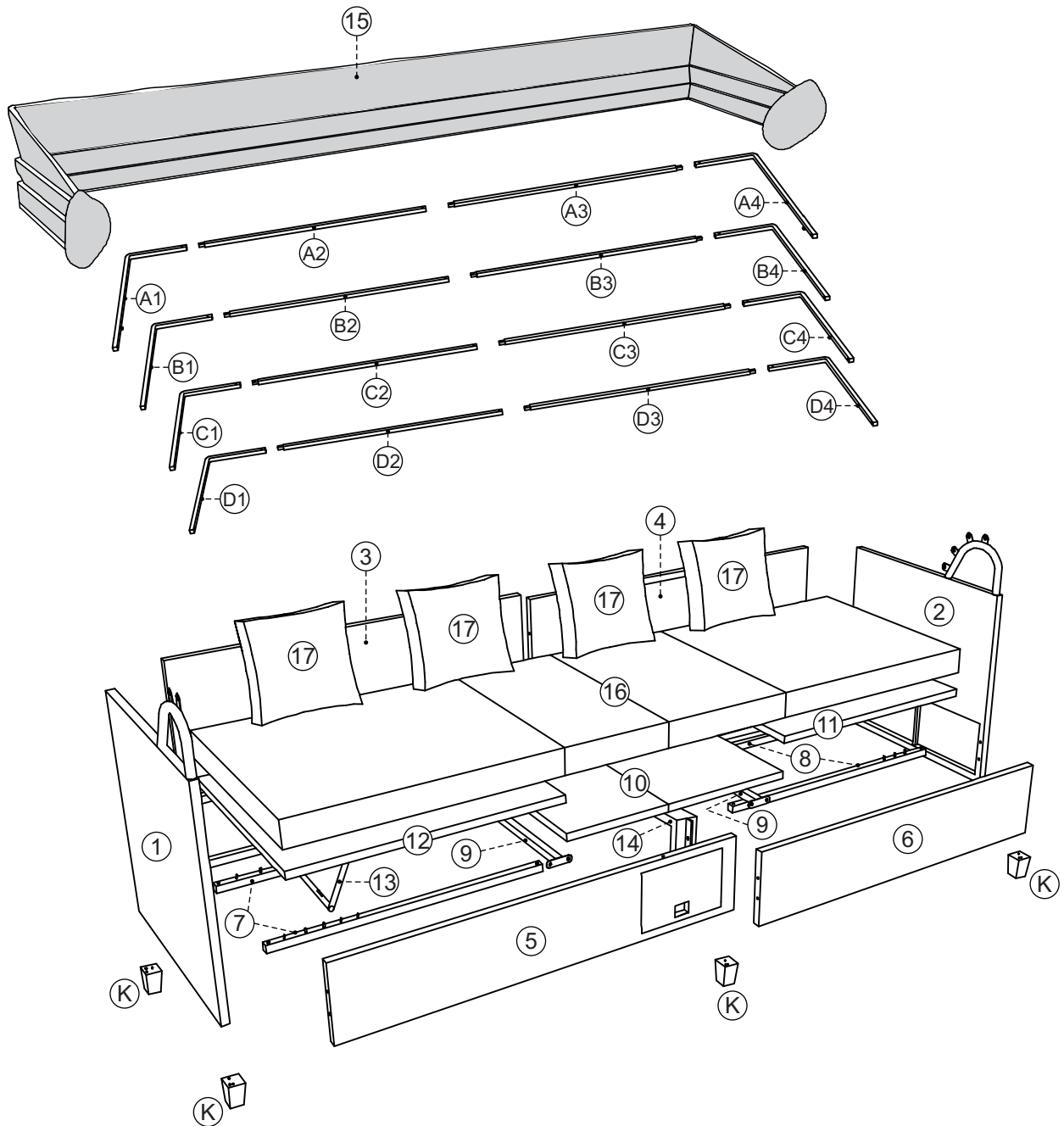

Assembly Instruction

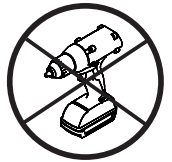
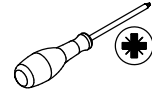

1

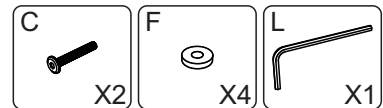
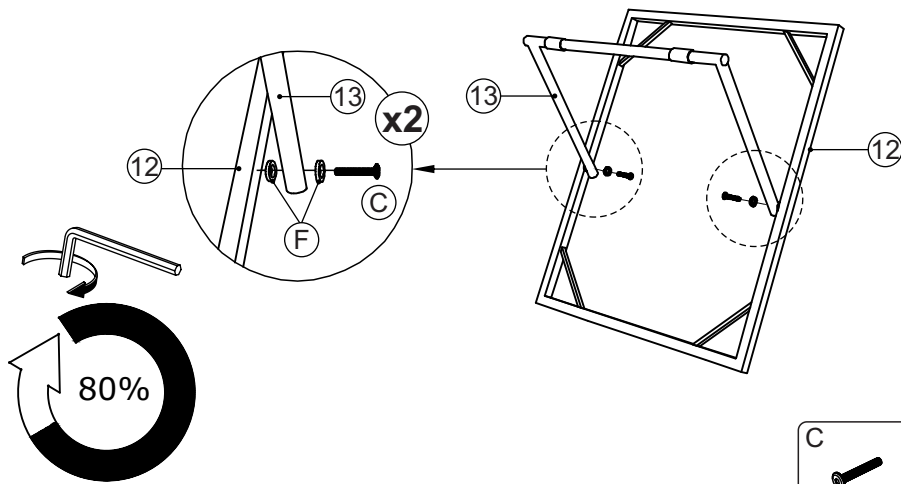

2

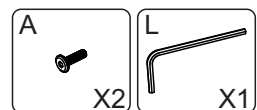
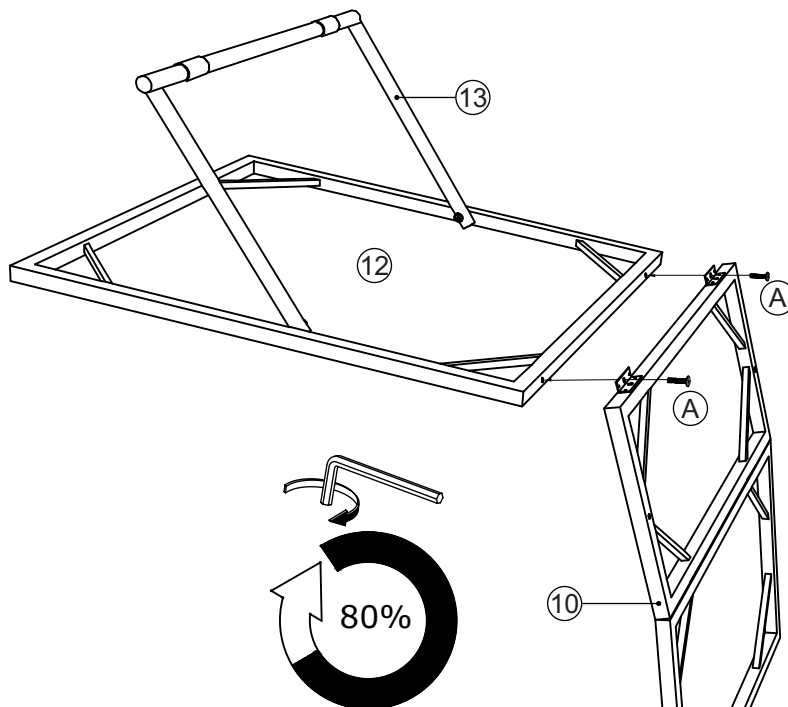

Assembly Instruction

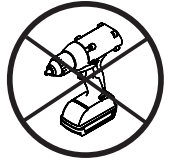
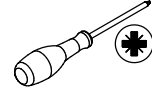

3

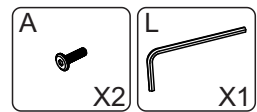
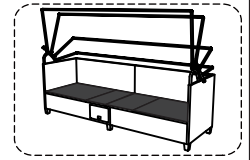
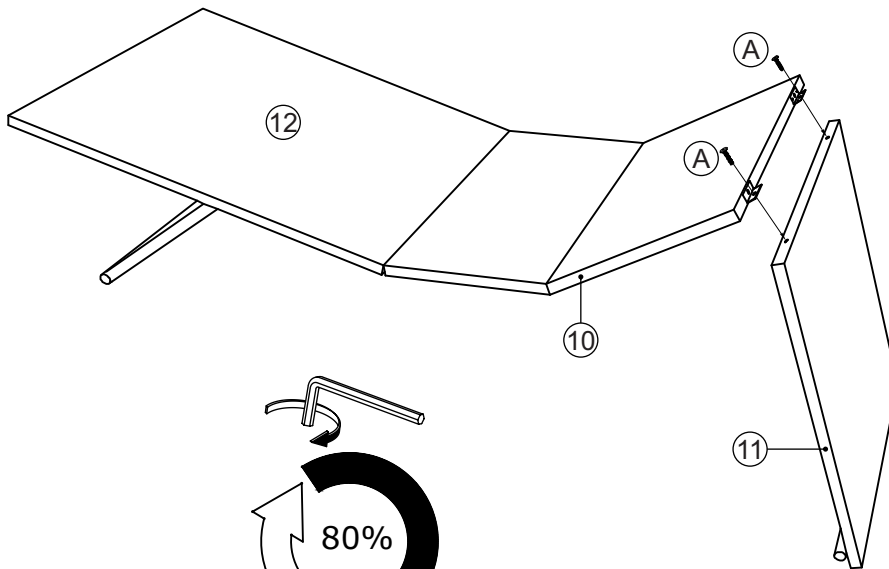

4

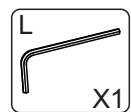
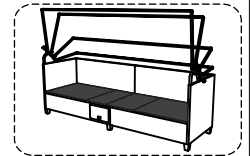
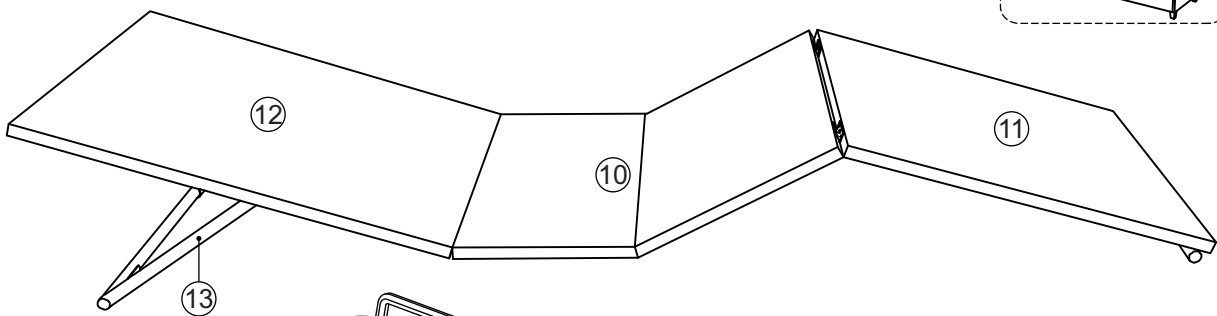

Assembly Instruction

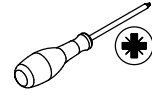

5

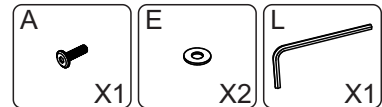
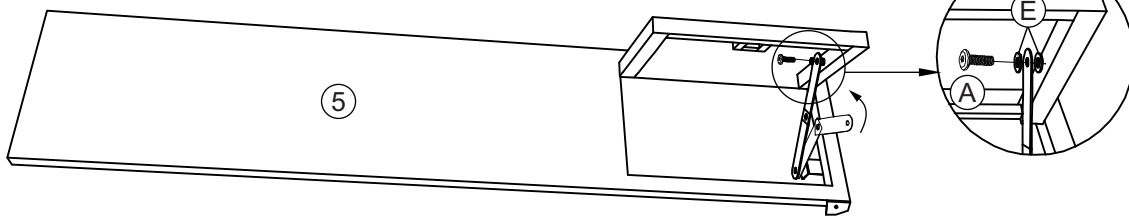
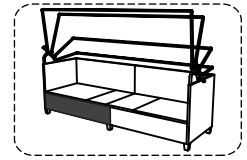
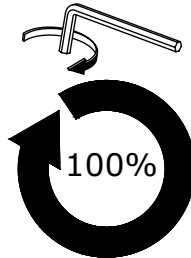

6

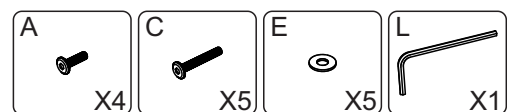
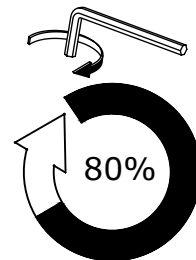
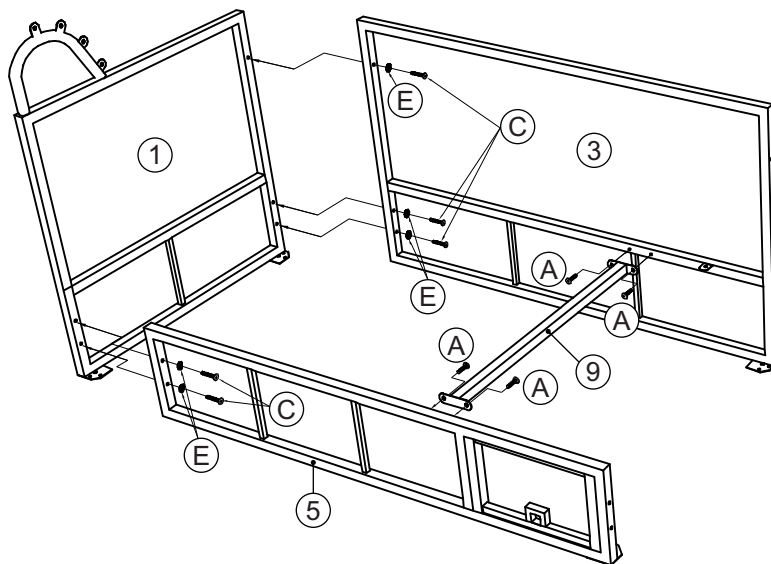
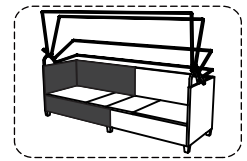

Assembly Instruction

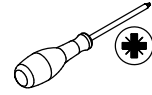

7

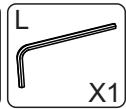
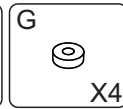
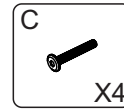
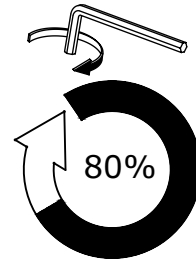
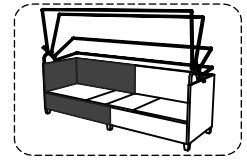
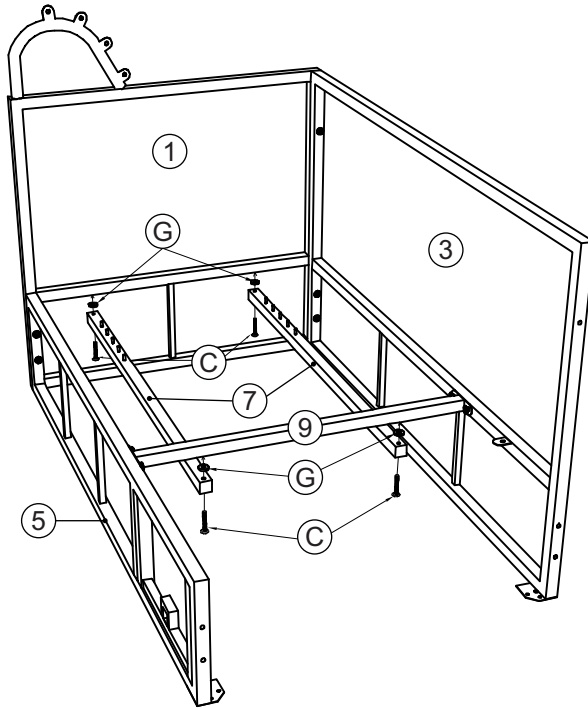

8

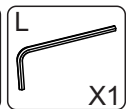
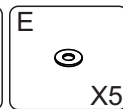
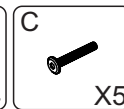
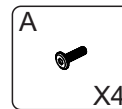
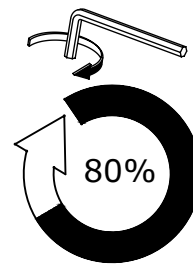
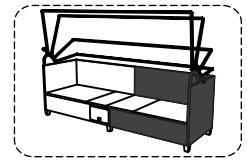
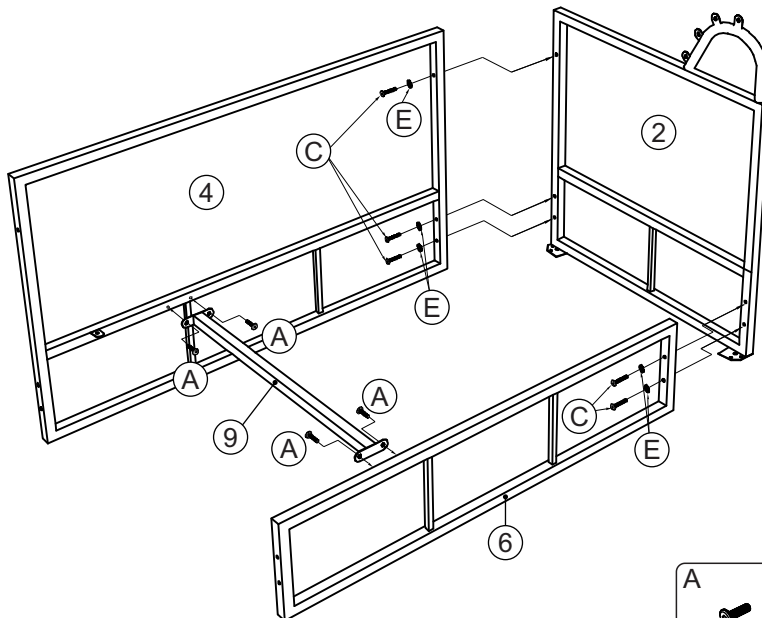

Assembly Instruction

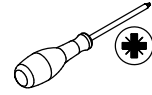

9

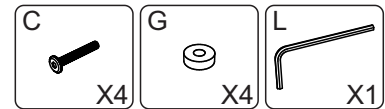
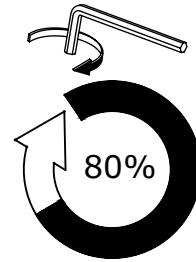
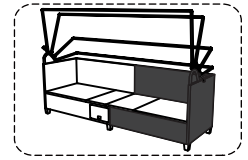
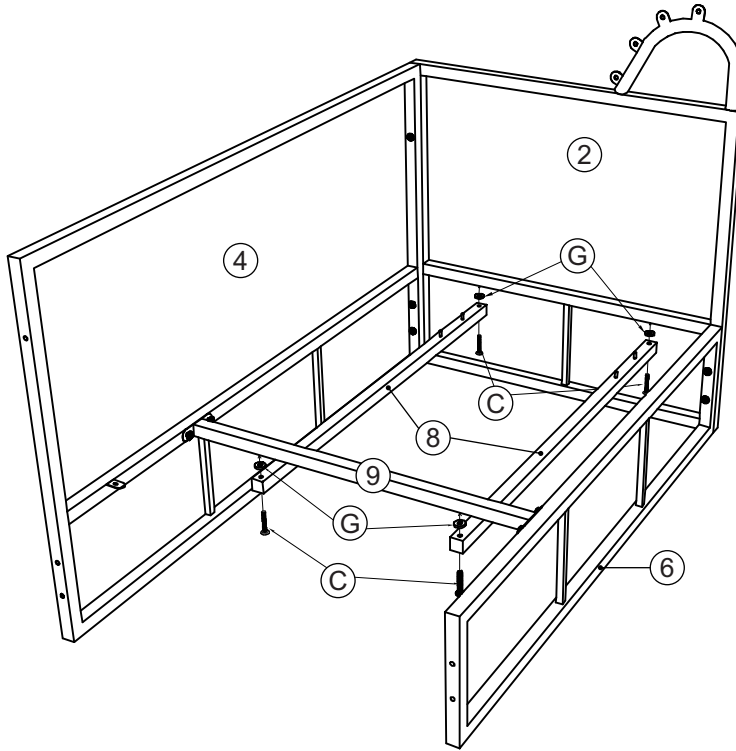

10

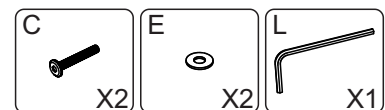
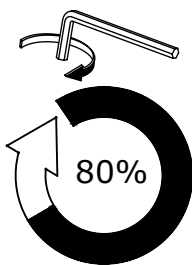
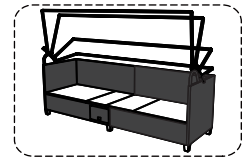
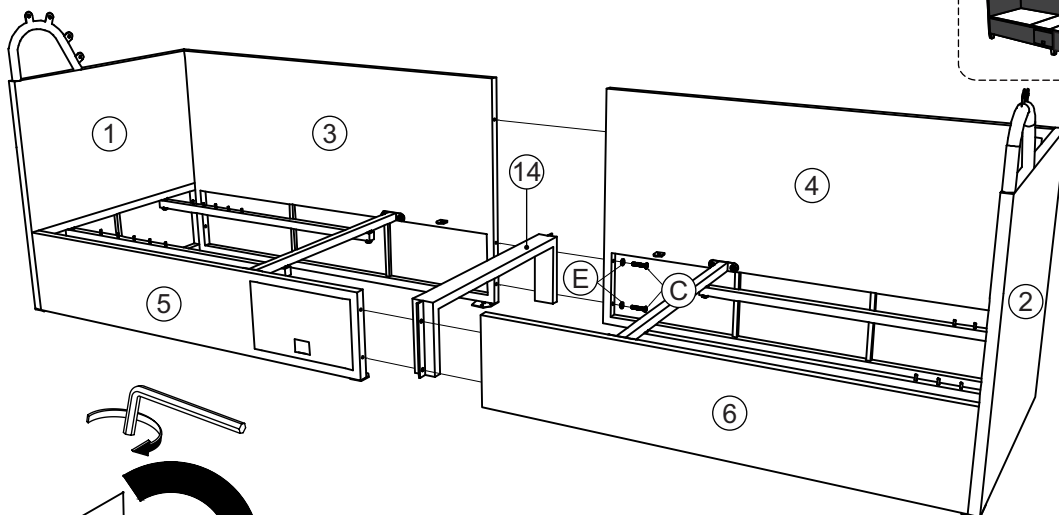

Assembly Instruction

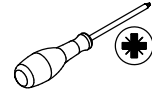

11

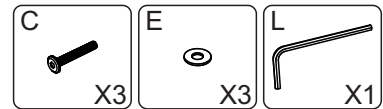
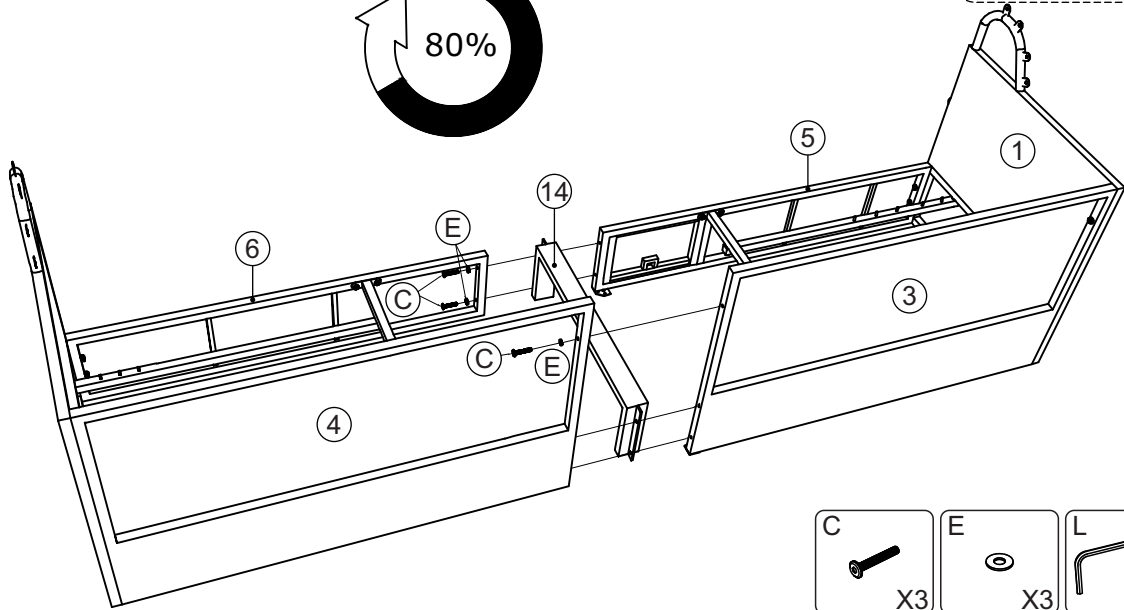
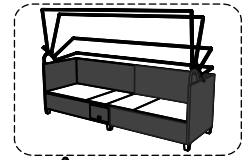
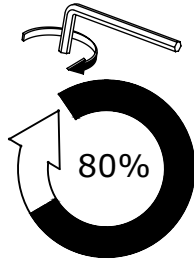

12

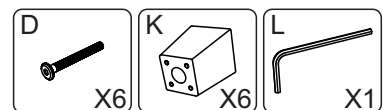
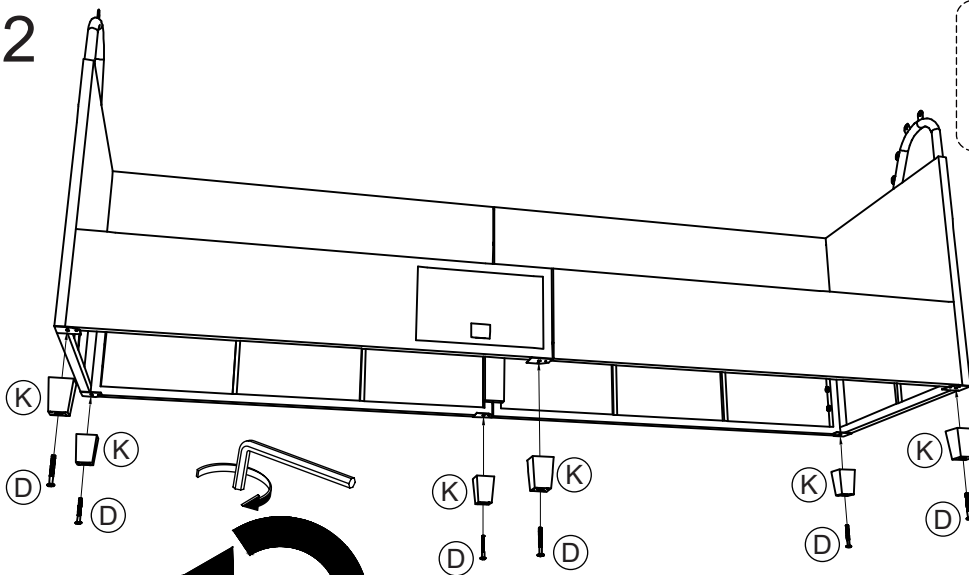
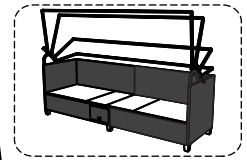
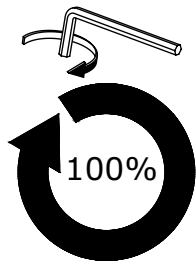

Assembly Instruction

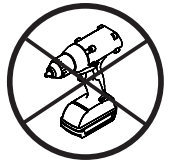
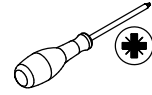

13

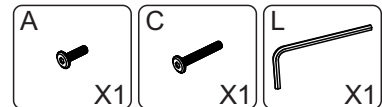
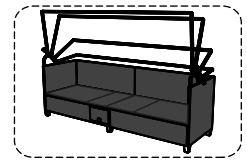
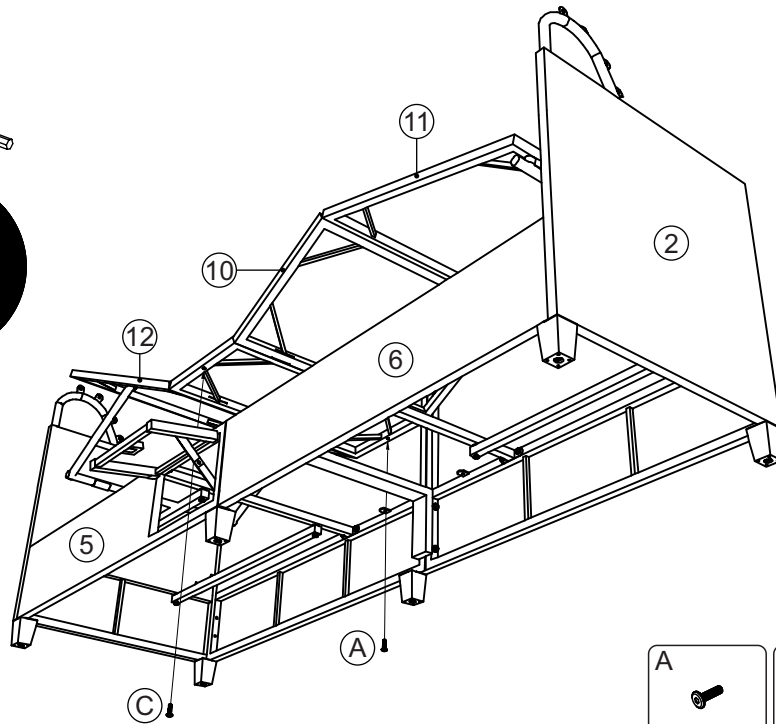
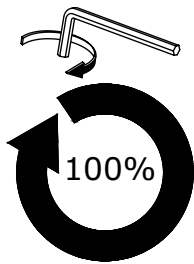

14

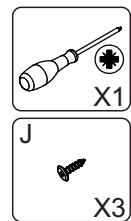
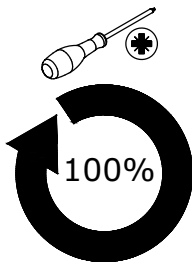
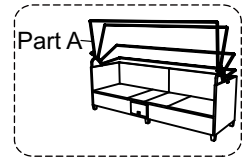
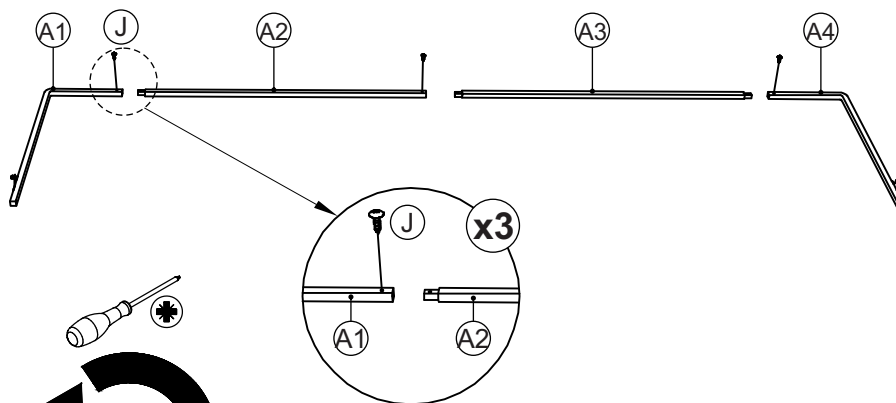

Assembly Instruction

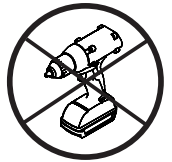
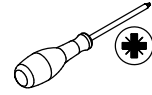

15

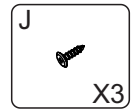
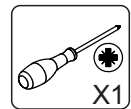
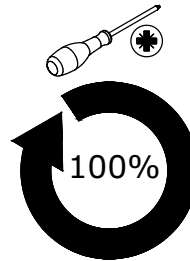
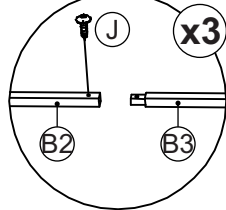
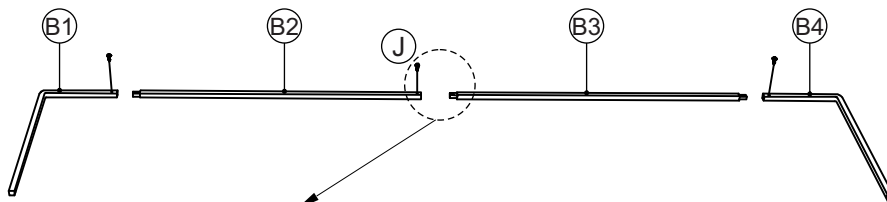
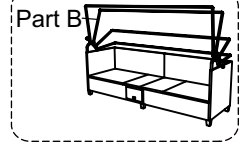

16

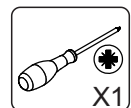
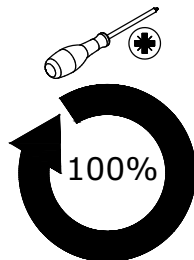
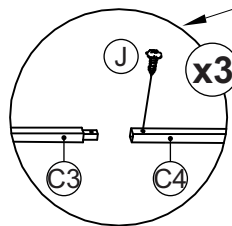
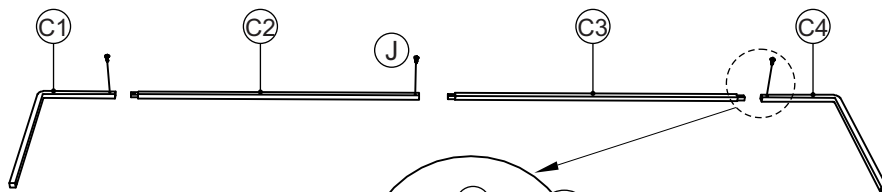
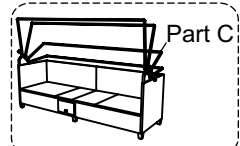

Assembly Instruction

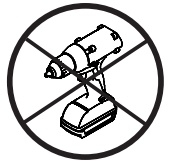
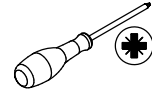

17

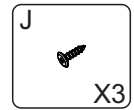
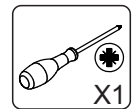
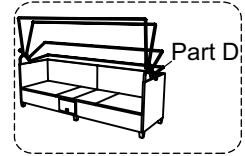
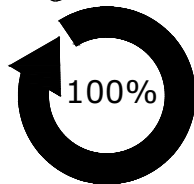
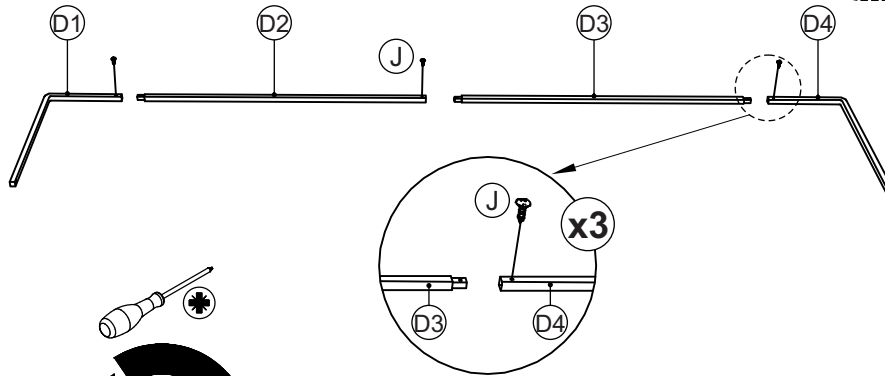

18

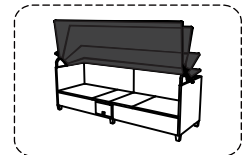
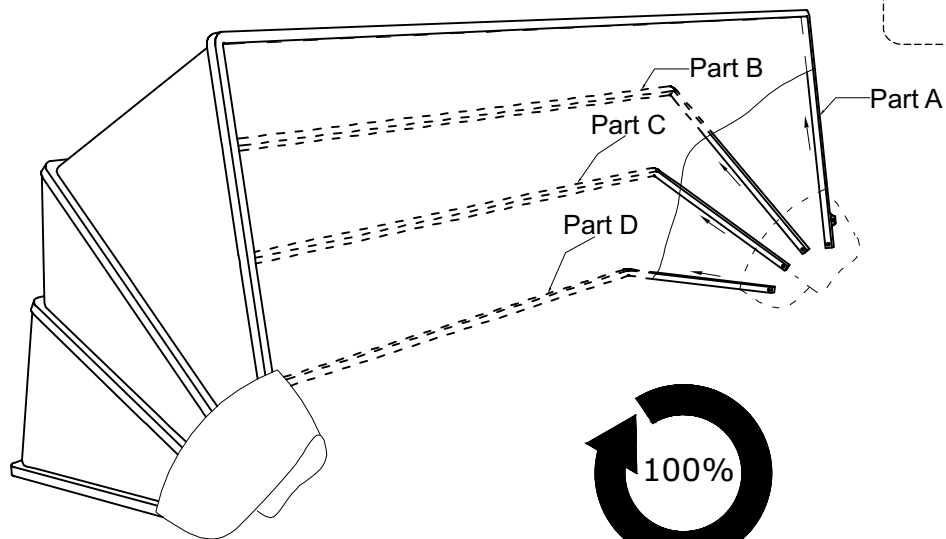



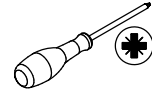

Assembly Instruction

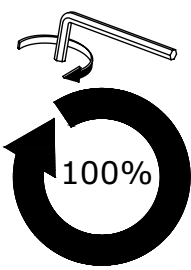
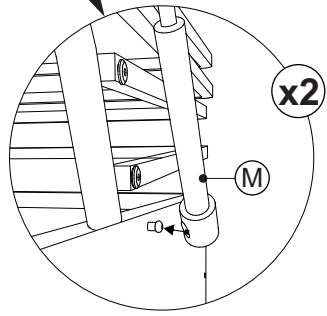
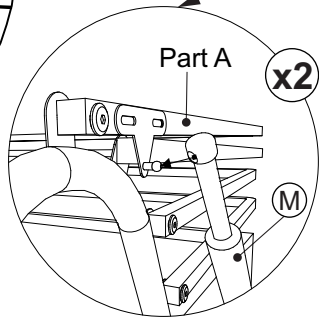
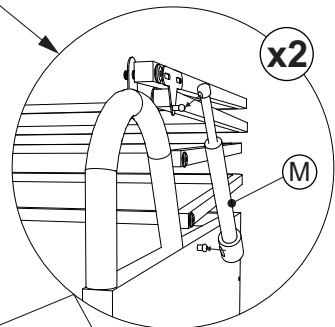
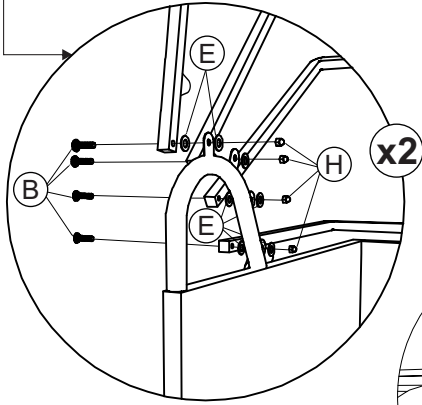
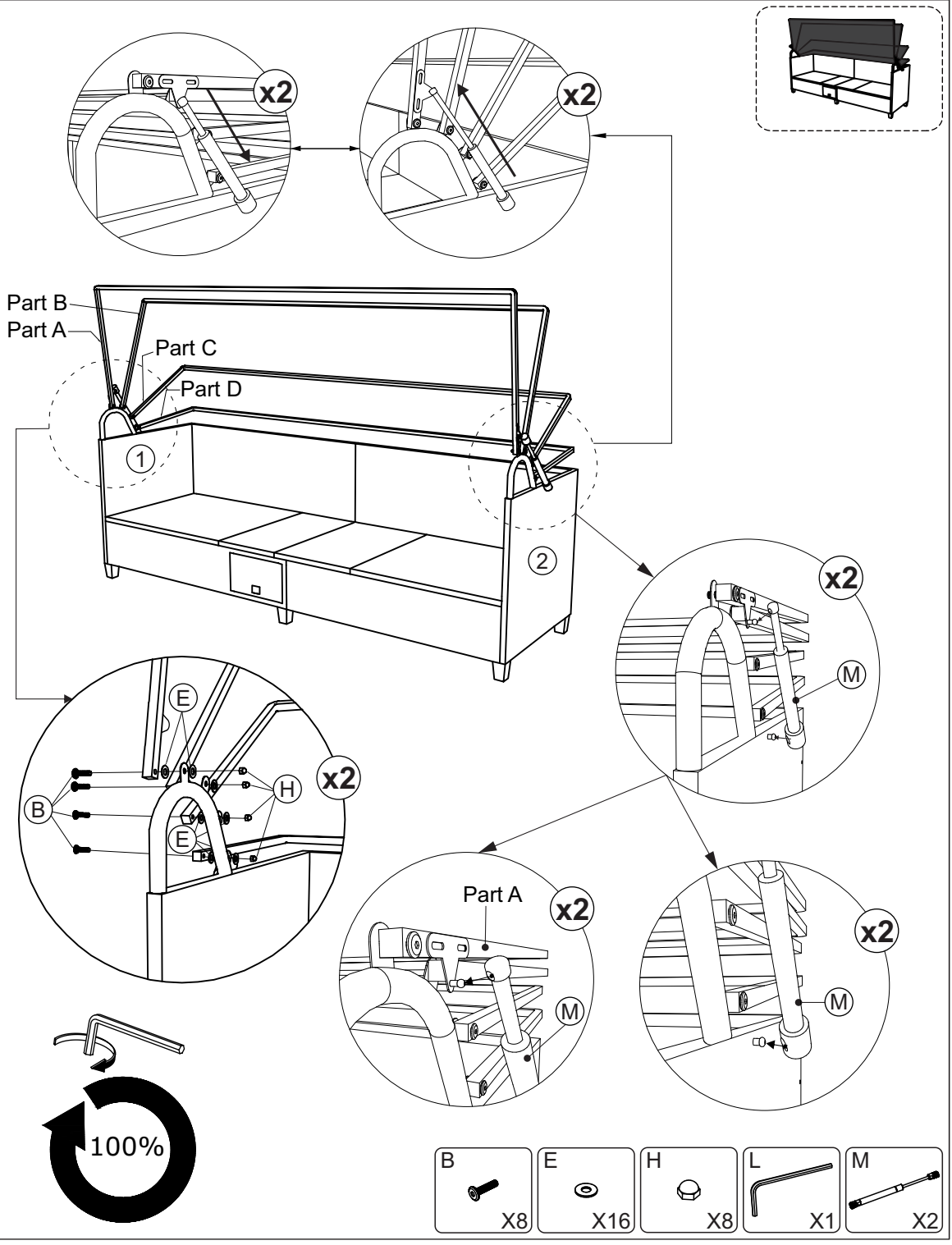

19



- | | | | | |
|---|--|---|---|---|
| B

X8 | E

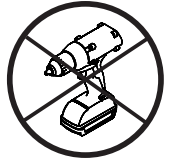
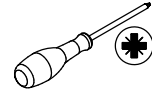
X16 | H

X8 | L

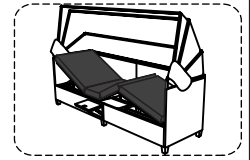
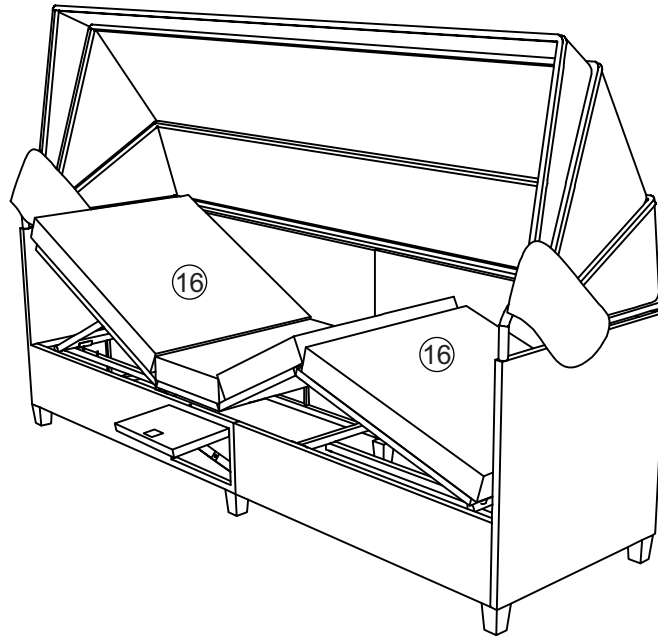
X1 | M

X2 |
|---|--|---|---|---|

Assembly Instruction



20



21

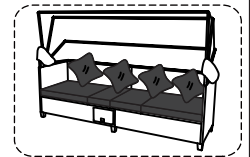
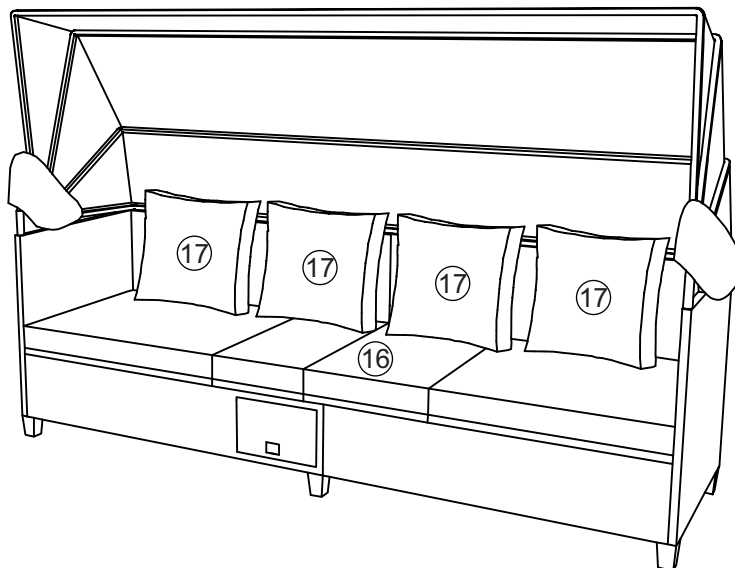

ok

Care Advice



For more information
and care advice
please use the QR-code



FR

Donnez ou recyclez
vos meubles.



Association

ou



Magasin

ou



Déchèterie

<https://quefairedemesdechets.fr>

**Venture
home**



www.venturehome.se
www.venturedesign.se



@venturehomese
@venture.design

**SE**

VIKTIGT! Läs bruksanvisningen i sin helhet innan du börjar att montera och/eller använda produkten. Följ bruksanvisningen noggrant och spara den för framtida referens. Var försiktig vid montering, om skruvarna dras åt för hårt (eller med skruvdragare), kan skador på ytan uppstå. Dra inte åt skruvarna förrän alla skruvar har monterats! Kontrollera regelbundet att alla fästansordningar är ordentligt åtdragna, och dra åt dem på nytt när det behövs.

GB

IMPORTANT! Read the entire instruction manual before you begin assembling and/or using the product. Follow the instructions carefully and keep them for future reference. Be careful during assembly; if the screws are tightened too much (or with a power screwdriver), surface damage may occur. Do not tighten the screws until all screws have been assembled! Regularly check that all fastenings are properly tightened and retighten them as needed.

DE

WICHTIG! Lesen Sie die gesamte Bedienungsanleitung, bevor Sie mit dem Zusammenbau und/oder der Verwendung des Produkts beginnen. Befolgen Sie die Anweisungen sorgfältig und bewahren Sie sie für zukünftige Zwecke auf. Seien Sie beim Zusammenbau vorsichtig; wenn die Schrauben zu fest angezogen werden (oder mit einem Akkuschräuber), kann die Oberfläche beschädigt werden. Ziehen Sie die Schrauben erst fest, wenn alle Schrauben montiert sind! Überprüfen Sie regelmäßig, ob alle Befestigungen richtig angezogen sind, und ziehen Sie sie bei Bedarf nach.

FR

IMPORTANT! Lisez l'intégralité du manuel d'instructions avant de commencer à assembler et/ou à utiliser le produit. Suivez attentivement les instructions et conservez-les pour référence ultérieure. Soyez prudent lors de l'assemblage ; si les vis sont trop serrées (ou avec une visseuse électrique), des dommages à la surface peuvent survenir. Ne serrez pas les vis tant que toutes les vis ne sont pas assemblées! Vérifiez régulièrement que tous les fixations sont correctement serrées et resserrez-les si nécessaire.

NL

BELANGRIJK! Lees de gehele handleiding voordat u begint met het monteren en/of gebruiken van het product. Volg de instructies zorgvuldig op en bewaar ze voor toekomstige referentie. Wees voorzichtig tijdens de montage; als de schroeven te strak worden aangedraaid (of met een elektrische schroevendraaier), kan schade aan het oppervlak ontstaan. Draai de schroeven niet vast totdat alle schroeven zijn gemonteerd! Controleer regelmatig of alle bevestigingen goed vastzitten, en draai ze indien nodig opnieuw aan.

DK

VIGTIG! Læs hele brugsanvisningen, inden du begynder at samle og/eller bruge produktet. Følg brugsanvisningen nøje og gem den til senere brug. Vær forsigtig under samlingen; hvis skruerne strammes for meget (eller med en skruetrækker), kan der opstå skader på overfladen. Stram ikke skruerne, før alle skruer er samlet! Kontroller regelmæssigt, at alle fastgørelsesanordninger er ordentligt fastgjort, og stram dem efter behov.

IE

MIKILVÆGT! Lestu notendahandbókina í heild sinni áður en þú byrjar að setja saman og/eða nota vöruna. Fylgdu leiðbeiningunum vandlega og geymdu þær til framtíðarviðmiðunar. Gætið varúðar við samsetningu; ef skrufurnar eru hertar of mikið (eða með rafmagnsskrúfjárn) getur yfirborðsskemmdir orðið. Ekki herða skrufurnar fyrr en allar skrufur hafa verið settar saman! Athugaðu reglulega að allar festingar séu vel hertar, og hertu þær aftur eftir þörfum.

NO

VIKTIG! Les hele bruksanvisningen før du begynner å montere og/eller bruke produktet. Følg bruksanvisningen nøye og oppbevar den for fremtidig referanse. Vær forsiktig under montering; hvis skruene strammes for mye (eller med en skrutrekker), kan det oppstå skader på overflaten. Ikke stram skruene før alle skruene er montert! Sjekk regelmessig at alle festene er ordentlig strammet, og stram dem på nytt ved behov.

FI

TÄRKEÄÄ! Lue koko käyttöohje ennen kuin alat koota ja/tai käyttää tuotetta. Noudata ohjeita huolellisesti ja säilytä ne tulevaa käyttöä varten. Ole varovainen kokoamisen aikana; jos ruuvit kiristetään liian tiukasti (tai sähköruuvimeisselillä), pintavaurioita voi syntyä. Älä kiristä ruuveja, ennen kuin kaikki ruuvit on koottu! Tarkista säännöllisesti, että kaikki kiinnikkeet ovat kunnolla kiinni, ja kiristä ne uudelleen tarvittaessa.

CZ

DŮLEŽITÉ! Přečtěte si celý návod k použití, než začnete výrobek montovat a/nebo používat. Dodržujte pokyny pečlivě a uschovejte si je pro budoucí použití. Buďte při montáži opatrní; pokud jsou šrouby příliš utaženy (nebo pomocí elektrického šroubováku), může dojít k poškození povrchu. Neutahujte šrouby, dokud nejsou všechny šrouby smontovány! Pravidelně kontrolujte, zda jsou všechny upevňovací prvky řádně utaženy, a v případě potřeby je znovu dotáhněte.

ES

¡IMPORTANTE! Lea todo el manual de instrucciones antes de comenzar a montar y/o usar el producto. Siga las instrucciones cuidadosamente y guárdelas para futuras referencias. Tenga cuidado durante el montaje; si los tornillos se aprietan demasiado (o con un destornillador eléctrico), puede producirse daño en la superficie. No apriete los tornillos hasta que todos los tornillos estén montados. Revise regularmente que todos los sujetadores estén bien apretados y vuelva a apretarlos cuando sea necesario.

**IT**

IMPORTANTE! Leggere attentamente l'intero manuale di istruzioni prima di iniziare ad assemblare e/o utilizzare il prodotto. Seguire attentamente le istruzioni e conservarle per future consultazioni. Fare attenzione durante l'assemblaggio; se le viti vengono serrate troppo (o con un avvitatore), si potrebbero verificare danni alla superficie. Non stringere le viti fino a quando tutte le viti non sono state assemblate! Controllare regolarmente che tutti i fissaggi siano ben serrati e serrarli nuovamente se necessario.

HU

FONTOS! Olvassa el a teljes használati útmutatót, mielőtt megkezdi a termék összeszerelését és/vagy használatát. Gondosan kövesse az utasításokat, és őrizze meg a jövőbeni hivatkozás céljából. Legyen óvatos az összeszerelés során; ha a csavarokat túlzottan meghúzzák (vagy elektromos csavarhúzóval), felületi károsodás léphet fel. Ne húzza meg a csavarokat, amíg az összes csavart össze nem szerelte! Rendszeresen ellenőrizze, hogy az összes rögzítőelem megfelelően meghúzott-e, és szükség esetén húzza meg újra.

PL

WAŻNE! Przeczytaj całą instrukcję obsługi przed rozpoczęciem montażu i/lub używania produktu. Postępuj zgodnie z instrukcjami uważnie i zachowaj je na przyszłość. Uważaj podczas montażu; jeśli śruby są zbyt mocno dokręcone (lub za pomocą wkrętarki), może dojść do uszkodzenia powierzchni. Nie dokręcaj śrub, dopóki wszystkie śruby nie zostaną zamontowane! Regularnie sprawdzaj, czy wszystkie elementy mocujące są odpowiednio dokręcone, i w razie potrzeby dokręć je ponownie.

EE

TÄHTIS! Lugege kasutusjuhendit tervikuna, enne kui alustate toote kokkupanekut ja/või kasutamist. Järgige juhiseid hoolikalt ja hoidke need edaspidiseks viitamiseks alles. Olge kokkupanekul ettevaatlik; kui kruvid on liiga kõvasti kinni keeratud (või kruvikeerajaga), võib pind kahjustuda. Ärge pingutage kruvisid, enne kui kõik kruvid on kokku pandud! Kontrollige regulaarselt, et kõik kinnitusvahendid oleksid korralikult kinnitatud, ja pingutage neid vajadusel uuesti.

LT

SVARIGI! Pirms sākat montēt un/vai izmantot izstrādājumu, izlasiet visu lietošanas instrukciju. Rūpīgi izpildiet norādījumus un saglabājiet tos turpmākai izmantošanai. Esi uzmanīgs montāžas laikā; ja skrūves tiek pievilktas pārāk cieši (vai ar elektrisko skrūvgriezi), var rasties virsmas bojājumi. Nepievelciet skrūves, līdz visas skrūves nav saliktas! Regulāri pārbaudiet, vai visas stiprinājuma detaļas ir pareizi pievilktas, un nepieciešamības gadījumā pievelciet tās atkārtoti.

LV

SVARBU! Prieš pradēdami surinkimā ir/arba naudoti produkta, perskaitykite visą naudojimo instrukciją. Atidžiai laikykite instrukciją ir laikykite jas ateityje. Būkite atsargūs surinkimo metu; jei varžtai bus per daug priveržti (arba naudojant elektrinį atsuktuvą), gali atsirasti paviršiaus pažeidimų. Nesukite varžtų, kol visi varžtai nebus surinkti! Reguliariai tikrinkite, ar visi tvirtinimo elementai yra tinkamai priveržti, ir prireikus priveržkite juos iš naujo.

PT

IMPORTANTE! Leia o manual de instruções completo antes de começar a montar e/ou usar o produto. Siga as instruções cuidadosamente e guarde-as para referência futura. Tenha cuidado durante a montagem; se os parafusos forem apertados demais (ou com uma chave de fenda elétrica), podem ocorrer danos na superfície. Não aperte os parafusos até que todos os parafusos estejam montados! Verifique regularmente se todos os fixadores estão devidamente apertados e reaperte-os conforme necessário.

RO

IMPORTANT! Citiți întregul manual de instrucțiuni înainte de a începe asamblarea și/sau utilizarea produsului. Urmați cu atenție instrucțiunile și păstrați-le pentru referințe viitoare. Fiți atent în timpul asamblării; dacă șuruburile sunt strânse prea mult (sau cu o șurubelniță electrică), pot apărea daune la suprafață. Nu strângeți șuruburile până când toate șuruburile nu sunt asamblate! Verificați periodic dacă toate dispozitivele de fixare sunt bine strânse și strângeți-le din nou, dacă este necesar.

SK

DÔLEŽITÉ! Pred začatím montáže a/alebo používaním produktu si prečítajte celý návod na použitie. Starostlivo dodržujte pokyny a uschovajte si ich pre budúce použitie. Buďte pri montáži opatrní; ak sú skrutky príliš dotiahnuté (alebo pomocou elektrického skrutkovača), môže dôjsť k poškodeniu povrchu. Neutahujte skrutky, kým nie sú všetky skrutky zmontované! Pravidelne kontrolujte, či sú všetky upevňovacie prvky správne utiahnuté, a v prípade potreby ich znovu dotiahnite.

BG

ВАЖНО! Прочетете цялото ръководство за употреба, преди да започнете да сглобявате и/или използвате продукта. Внимателно следвайте инструкциите и ги запазете за бъдеща справка. Бъдете внимателни при сглобяване; ако винтовете са прекалено затегнати (или с отвертка), може да се получат повреди на повърхността. Не затягвайте винтовете, докато всички винтове не са сглобени! Редовно проверявайте дали всички крепежни елементи са правилно затегнати, и ги затягвайте отново при необходимост.

**HR**

VAŽNO! Pročitajte cijeli priručnik prije nego što počnete sastavljati i/ili koristiti proizvod. Pažljivo slijedite upute i sačuvajte ih za buduću upotrebu. Budite pažljivi tijekom sastavljanja; ako se vijci previše stegnu (ili s električnim odvijačem), može doći do oštećenja površine. Nemojte zatezati vijke dok svi vijci nisu sastavljeni! Redovito provjeravajte jesu li svi pričvrtni elementi pravilno zategnuti i po potrebi ih ponovno zategnite.

GR

ΣΗΜΑΝΤΙΚΟ! Διαβάστε ολόκληρο το εγχειρίδιο οδηγιών πριν ξεκινήσετε τη συναρμολόγηση και/ή χρήση του προϊόντος. Ακολουθήστε προσεκτικά τις οδηγίες και φυλάξτε τις για μελλοντική αναφορά. Να είστε προσεκτικοί κατά τη συναρμολόγηση. Εάν οι βίδες σφίγγονται υπερβολικά (ή με ηλεκτρικό κατσαβίδι), μπορεί να προκληθούν ζημιές στην επιφάνεια. Μην σφίγγετε τις βίδες μέχρι να συναρμολογηθούν όλες οι βίδες! Ελέγχετε τακτικά ότι όλα τα στηρίγματα είναι σωστά σφιγμένα και τα ξανασφίγγετε όταν χρειάζεται.

RU

ВАЖНО! Прочтите всю инструкцию перед началом сборки и/или использования продукта. Внимательно следуйте инструкциям и сохраните их для будущего использования. Будьте осторожны при сборке; если винты будут затянуты слишком сильно (или с помощью шуруповерта), это может привести к повреждению поверхности. Не затягивайте винты, пока все винты не будут собраны! Регулярно проверяйте, что все крепежные элементы затянуты должным образом, и при необходимости подтягивайте их снова.

SI

POMEMBNO! Preden začnete sestavljanje in/ali uporabo izdelka, preberite celoten priročnik z navodili. Skrbno upoštevajte navodila in jih shranite za prihodnjo uporabo. Bodite previdni pri sestavljanju; če so vijaki premočno zategnjeni (ali z električnim izvijačem), lahko pride do poškodb površine. Vijakov ne zategnite, dokler niso vsi vijaki sestavljeni! Redno preverjajte, ali so vsi pritrdilni elementi pravilno zategnjeni, in jih po potrebi ponovno zategnite.

MT

IMPORTANTI! Aqra l-istruzzjonijiet għall-użu kollha qabel tibda tiġbor u/jew tuża l-prodott. Segwi l-istruzzjonijiet bir-reqqa u żommhom għal referenza futura. Oqgħod attent waqt l-assemblaġġ, jekk il-viti jinġibdu wisq (jew bi tornavit elettriku), jistgħu jikkawżaw ħsara lill-wiċċ. Thaffix il-viti qabel ma l-viti kollha jkunu mwahħla flimkien! Iċċekkja regolarment li l-immuntar kollu hu ssikkat sew, u ssikka mill-ġdid meta jkun meħtieġ.